

APRIL, 1941

EMERGENCY STANDARD
No. (E) D.2510—1941
being
British Air Ministry Specification
No. A.G.S. 157*
endorsed with amendments.

STANDARDS ASSOCIATION OF AUSTRALIA.

Headquarters :

Science House, Gloucester and Essex Streets, Sydney.

AUSTRALIAN STANDARD SPECIFICATION FOR AIRCRAFT MATERIAL
(Emergency Series)

LIGHT ALLOY WASHERS (Large Diameter)

This standard forms one of a series prepared by the Standards Association of Australia at the request of Departments of the Commonwealth Government for use in relation to the supply of materials required for defence purposes. In appropriate cases these specifications will be reviewed for inclusion in the normal series of Australian Standards.

1. Material. All washers shall be made from approved aluminium alloy bar, sheet, or wire, having a Brinell hardness not less than 120 when tested in accordance with B.S. No. 240, "Methods and Tables for Brinell Hardness."

2. Manufacture. If required by the process of manufacture, the washers may have a split in a radial direction, but without any gap.

3. Dimensions. All washers shall be in accordance with the dimensions and tolerances given in Table I.

4. Finish. All washers shall be anodically treated.

TABLE I.

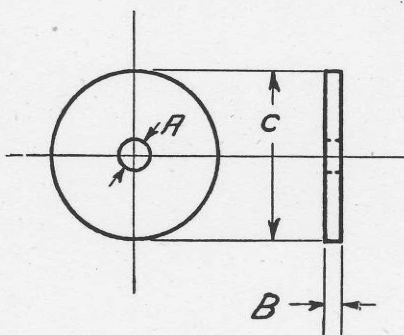

| Mark | Nominal Size | Tolerances | | |
|------|-------------------|------------------|--------------------------|------------------|
| | | A ± 0.02 in. | B ± 0.005 s.w.g. in. | C ± 0.03 in. |
| A | 6 B.A. | .12 | 16 .064 | 1.0 |
| B | 4 B.A. | .15 | " " | 1.0 |
| C | 2 B.A. | .19 | " " | 1.25 |
| D | $\frac{1}{4}$ in. | .26 | " " | 1.25 |
| E | $\frac{5}{16}$ " | .32 | " " | 1.25 |
| F | $\frac{3}{8}$ " | .38 | 14 .08 | 1.5 |
| G | $\frac{7}{16}$ " | .44 | " " | 1.5 |
| H | $\frac{1}{2}$ " | .51 | " " | 1.5 |

*This Australian Standard is British Air Ministry Specification A.G.S. 157 with amendments regarding materials dimensions and chamfering. For reference to the specification in its amended form it is essential that the Australian classification number (E) D.2510 be used.

This specification, prepared by the Special Committee on Aircraft Materials and Components, was approved on behalf of the Council of the Association on 16th April, 1941.

NOTE.

In order to keep abreast of progress in the industries concerned, Australian standards are subject to periodical review. Suggestions for improvement, addressed to the Headquarters of the Association, will be welcomed.

Price 1/-, post free 1/2.

Copyright.