

MARK.	DIA OF PIPE	Z	Y	X	W	V	U	S	T
		B.S.P. THREAD	+ .005	DIA DRILL	+ .005 + .01"	+ .01"	+ .01"	+ .01" - .005	+ .02 - .0
A	3/16"	1/8"	.295"	1/8"	3/16"	.35"	.53"	.30"	.30"
B	1/4"	1/4"	.410"	3/16"	1/4"	.35"	.65"	.37"	.37"
BB	5/16"	19 T.P.I WHIT. FORM .60" O.D.	.480"	1/4"	5/16"	.40"	.70"	.43"	.42"
C	3/8"	3/8"	.550"	5/16"	3/8"	.40"	.74"	.49"	.45"
CC	7/16"	14 T.P.I WHIT. FORM .75" O.D.	.600"	3/8"	7/16"	.45"	.83"	.55"	.55"
D	1/2"	1/2"	.690"	7/16"	1/2"	.50"	.90"	.62"	.60"
E	5/8"	5/8"	.760"	9/16"	5/8"	.55"	.75"	.75"	.50"
F	3/4"	3/4"	.900"	1 1/16"	3/4"	.61"	.81"	.88"	.54"
G	7/8"	7/8"	1.040"	1 3/16"	7/8"	.65"	.85"	1.00"	.57"
H	1"	1"	1.130"	1 5/16"	1"	.65"	.85"	1.13"	.60"
J	1 1/4"	1 1/4"	1.450"	1 3/16"	1 1/4"	.65"	.85"	1.38"	.54"
K	1 1/2"	1 1/2"	1.680"	1 7/16"	1 1/2"	.70"	.90"	1.63"	.61"
L	1 3/4"	1 3/4"	1.920"	1 11/16"	1 3/4"	.70"	.90"	1.90"	.61"
M	2"	2"	2.150"	1 7/8"	2"	.75"	.95"	2.15"	.61"

THE MATERIAL TO BE BRASS TO B.S. SPEC. B.11. (LATEST ISSUE)

NOTE :- SCREW THREADS TO B.S. SPEC. NO. 84 - 1940. MEDIUM FIT, TRUNCATED THREADS TO AMENDMENT NO. 3. - 1945

FOR COMPLETE UNION ELBOWS SEE AGS. 1167 & AGS 1168.

FINISH :- NATURAL.

ISSUED BY THE ROYAL AIRCRAFT ESTABLISHMENT

TITLE :- PIPE COUPLINGS - UNION ELBOWS, UNION SLEEVE.

RETRACED BY GOV. AIRCRAFT FACTORIES D. A. P.

ISSUE NO.	1	2	3
ALTER. NO.	AGS 506	AGS 631	AGS 663

SEE A.G.S. 100 FOR
GENERAL INFORMATION.

MINISTRY OF
SUPPLY

AGS. No 1169

SHEET No 1 / No OF SHEETS 1

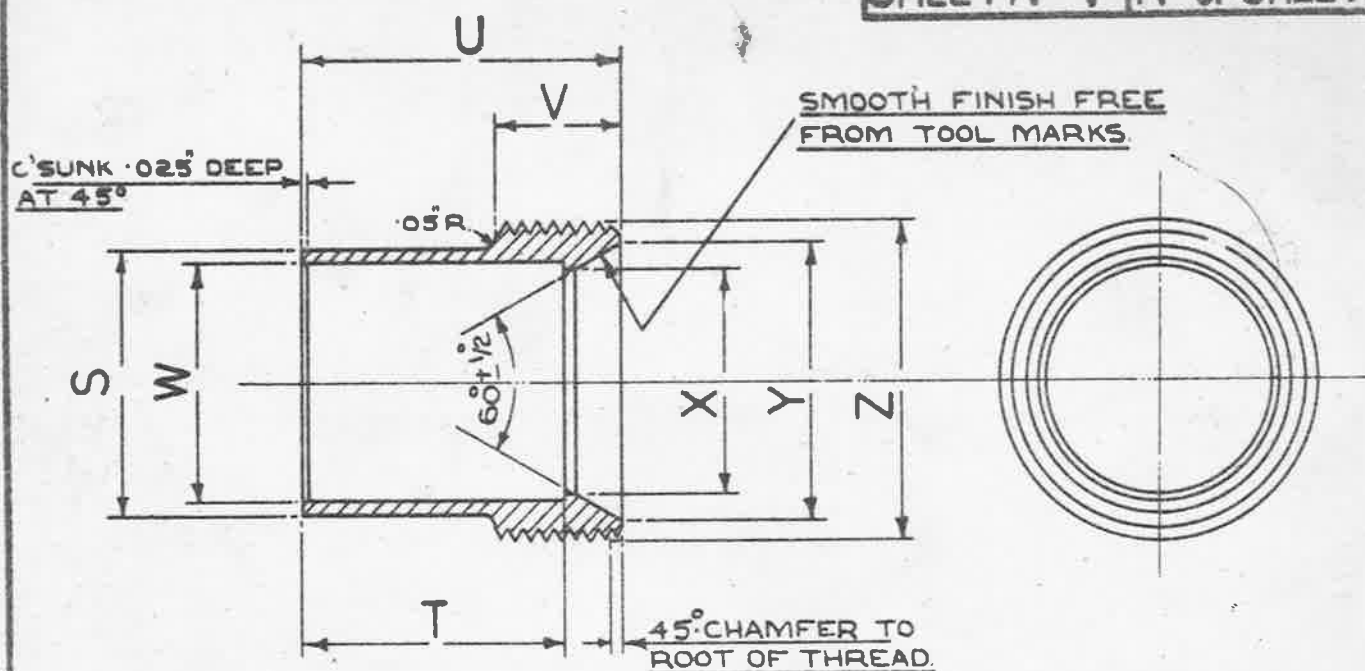

MARK.	DIA OF PIPE.	Z	Y	X	W	V	U	S	T
		B.S.F. THREAD	+ .005 - .005	DIA DRILL	+ .005" + .01"	± .01"	± .01"	+ .01" - .005"	+ .02" - 0
A	3/16"	1/8"	.295"	1/8"	3/16"	.35"	.53"	.30"	.30"
B	1/4"	1/4"	.410"	3/16"	1/4"	.35"	.65"	.37"	.37"
BB	5/16"	19 T.P.I. WHIT FORM .60" O/D.	.480"	1/4"	5/16"	.40"	.70"	.43"	.42"
C	3/8"	3/8"	.550"	5/16"	3/8"	.40"	.74"	.49"	.45"
CC	7/16"	14 T.P.I. WHIT FORM .75" O/D.	.600"	3/8"	7/16"	.45"	.83"	.55"	.55"
D	1/2"	1/2"	.690"	7/16"	1/2"	.50"	.90"	.62"	.60"
E	5/8"	5/8"	.760"	9/16"	5/8"	.55"	.75"	.75"	.50"
F	3/4"	3/4"	.900"	1 1/16"	3/4"	.61"	.81"	.88"	.54"
G	7/8"	7/8"	1.040"	1 3/16"	7/8"	.65"	.85"	1.00"	.57"
H	1"	1"	1.130"	1 5/16"	1"	.65"	.85"	1.13"	.60"
J	1 1/4"	1 1/4"	1.450"	1 3/16"	1 1/4"	.65"	.85"	1.38"	.54"
K	1 1/2"	1 1/2"	1.680"	1 7/16"	1 1/2"	.70"	.90"	1.63"	.61"
L	1 3/4"	1 3/4"	1.920"	1 1/2"	1 3/4"	.70"	.90"	1.90"	.61"
M	2"	2"	2.150"	1 7/8"	2"	.75"	.95"	2.15"	.61"

THE MATERIAL TO BE BRASS TO B.S. SPEC. B.11. (LATEST ISSUE)

NOTE :- SCREW THREADS TO B.S. SPEC. No 84-1940, MEDIUM FIT,
TRUNCATED THREADS TO AMENDMENT No 3-1945.

FOR COMPLETE UNION ELBOWS, SEE A.G.S. 1167 & AGS 1168.

FINISH :- NATURAL.

ISSUED BY THE ROYAL AIRCRAFT ESTABLISHMENT.	TITLE:- PIPE COUPLINGS:- UNION ELBOWS, UNION SLEEVE.					DRAWN. C.T. Reynolds.	TRACED J.A.B. 23-1-43
	ISSUE No	2	3	4	4	CHECKED Job Brasher	APPROVED. [Signature]
ALTER No	AGS/506	AGS/631	663	AS/AGS 988	SM 866		