

DESIGNED FOR FIRE EXTINGUISHER SYSTEMS.

SMOOTH FINISH FREE FROM TOOL MARKS.

MINISTRY OF SUPPLY

AGS.No.1185.

SHEET No.1.

No. OF SHEETS 1.

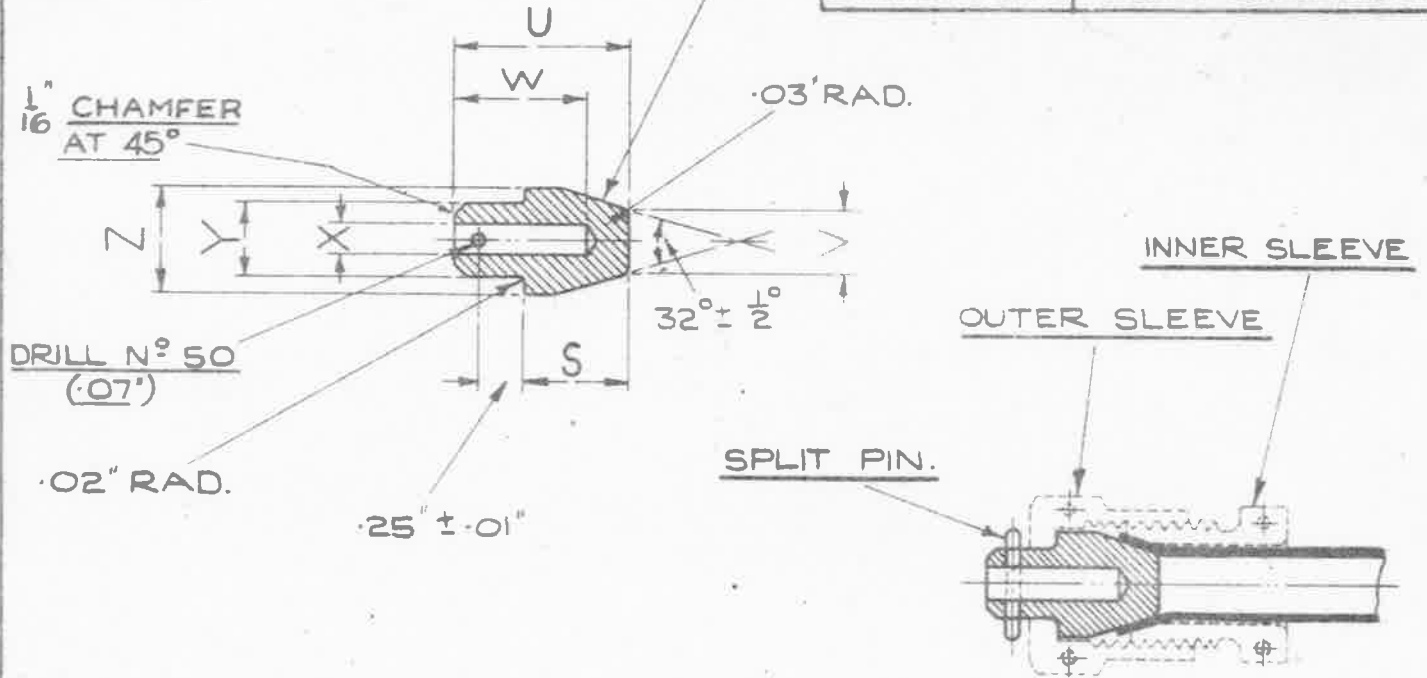

GENERAL ARRANGEMENT OF JOINT.

MARK	O/DIA OF PIPE	Z	Y	X	W	V	U	S	ITEMS REQUIRED TO COMPLETE JOINT.	
		±.01"	±.01"	DIA. DRILL	±.01"	±.010" -0	±.01"	±.01"	OUTER SLEEVE	SPLIT PIN.
BB	5/16"	.49"	.31"	NOT DRILLED	-	.267"	.85"	.48"	A.G.S. 904/BB	A.G.S. 166-2.
C	3/8"	.55"	.37"	3/16"	.69"	.333"	.91"	.54"	A.G.S. 904/C	A.G.S. 166-2.

FINISH:- TO BE CADMIUM PLATED TO SPEC: D.T.D. 904 (LATEST ISSUE), ALTERNATIVELY ELECTRO-TINNED, THICKNESS NOT LESS THAN .0002".

THE MATERIAL TO BE BRASS TO B.S. SPEC: 251 OR 249 (LATEST ISSUES).

NOTES:- WORKING PRESSURES: 3,000 LB/SQ.IN. FOR SIZES UP TO 1/2" B.S.P.  
 500 LB/SQ.IN. FOR SIZES 5/8" TO 1" B.S.P.  
 200 LB/SQ.IN. FOR SIZES 1/4" & 1/2" B.S.P.

ISSUED BY ROYAL AIRCRAFT ESTABLISHMENT.	TITLE:- PIPE COUPLINGS CONE PLUGS (BRASS)					DRAWN C.T.Reynolds	TRACED 24-9-45.
	ISSUE NO	1	2	3		CHECKED K.Wilson.	APPROVED 1/10/45
	ALTER-N NO	MOD AGS 600	AS AGS 663	AS AGS 877			