

OBSOLESCENT - NO  
 FURTHER MANUFACTURE -  
 EXISTING STOCKS TO BE USED.

AIR MINISTRY AGS. N<sup>o</sup> 1509.  
 SHEET N<sup>o</sup> 1 | N<sup>o</sup> OF SHEETS 1

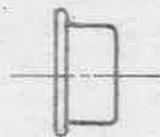

ACTUAL SIZE.

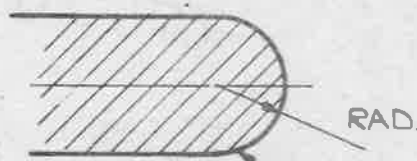

IMPORTANT-END MUST BE ROUNDED OFF  
AS SHOWN IN THE ENLARGED VIEW.

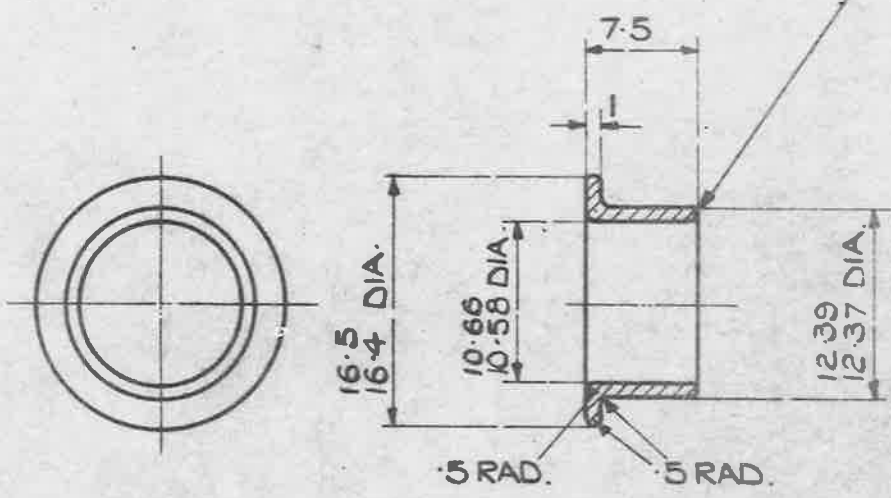

SCALE: 2/1.

NOTE:- ALL DIMENSIONS ARE IN MILLIMETRES.

MATERIAL:- BRASS. BEST COMMERCIAL QUALITY.

10-4-46

ISSUE N <sup>o</sup>	4 <sup>CR</sup>																				
ALT <sup>n</sup> N <sup>o</sup>	A.S. N <sup>o</sup> AGS/415																				
ISSUED BY DRAWING OFFICE DIRECTORATE OF TECHNICAL DEVELOPMENT AIR MINISTRY		TITLE:- SLEEVE. (INNER) FOR Ø $\frac{1}{4}$ " H.T. METAL BRAIDED CABLE.										DRAWN. J. BRASHER.		RE-TRACED B. LOGAN. 24-10-39.							
												CHECKED M.W. SHIPPEY. RE: CH. C.T. Reynolds		APPROVED. G.E. BAIRSTO. 24-9-37.							