

UNLIMITED DIMENSIONS  $\pm .005$ "

AG.S. 1517

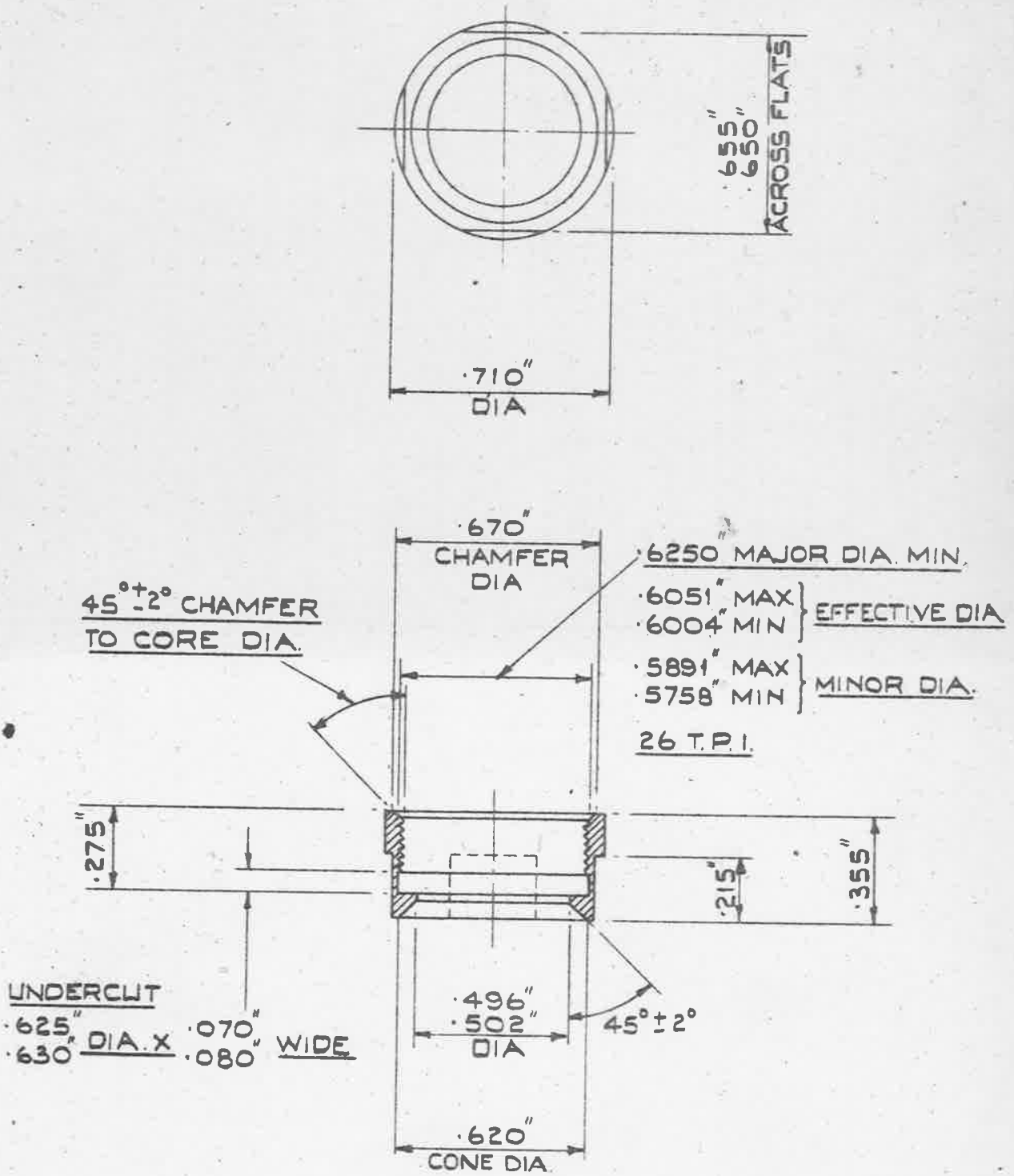

SCALE:- 2/1.

**MATERIAL:-** BRASS TO B.S. SPEC: 249 (LATEST ISSUE)

**FINISH:-** ELECTRO-TIN TO SPEC: D.T.D. 924 (LATEST ISSUE)

**NOTES:-** THREADS TO BE IN ACCORDANCE WITH B.S. SPEC: 84 (LATEST ISSUE), MEDIUM FIT.

ALL DIAMETRICAL SURFACES TO BE CONCENTRIC WITHIN .004" (T.C.R.)

ALL SHARP EDGES AND BURRS TO BE REMOVED

SM 590 SM 716

TITLE	H.T. CABLE		ISSUE	14	15				
	UNION NUT.		ALT. NO.	AS/AGS 876	AS/AGS 966				
MINISTRY OF SUPPLY	R.A.E. APPROVAL				A.D. S.A.E. APPROVAL				
	SIGNATURE		DATE		SIGNATURE		DATE		
APPLICATIONS FOR A.G.S. SHEETS TO:- A.T.P.4A. THAMES HOUSE, MILLBANK, S.W.1.		<i>J. Smith</i>		8.4.52		<i>G. I. Lambton</i>		27/6/52	
GENERAL INQUIRIES TO:- A.D. S.A.E. THAMES HOUSE, MILLBANK, S.W.1.		SHEET NO		1		A.G.S. No 1517			
		NO OF SHEETS		1					

ORIGINAL APPROVAL DATE 27.3.25