

FULL SIZE

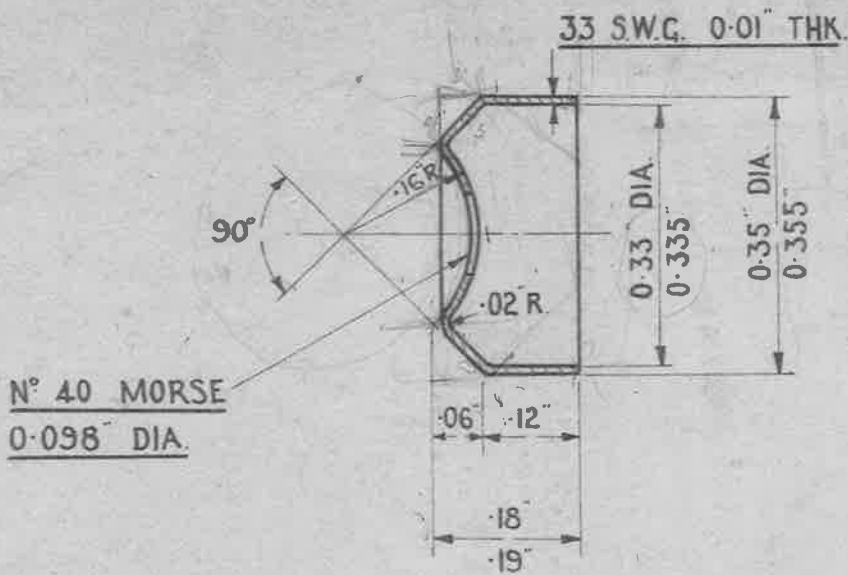

SCALE = 4/1

MATERIAL = BRASS, B.S. SPEC: 265 (LATEST ISSUE)

FINISH = TO BE ELECTRO-TINNED, THICKNESS NOT LESS THAN .0002"

ISSUED BY ROYAL AIRCRAFT ESTABLISHMENT	TITLE = THIMBLE FOR CAMBRIC COVERED H.T. CABLES.					RETRACED DIVISION OF AIRCRAFT PRODUCTION G. A. F.
	ISSUE N°	1	2	3	4	
	ALTERATION N°	AGS/69	AGS/86	AS AGS/270	AS AGS/663	

AGS. PENN.



FULL SIZE.

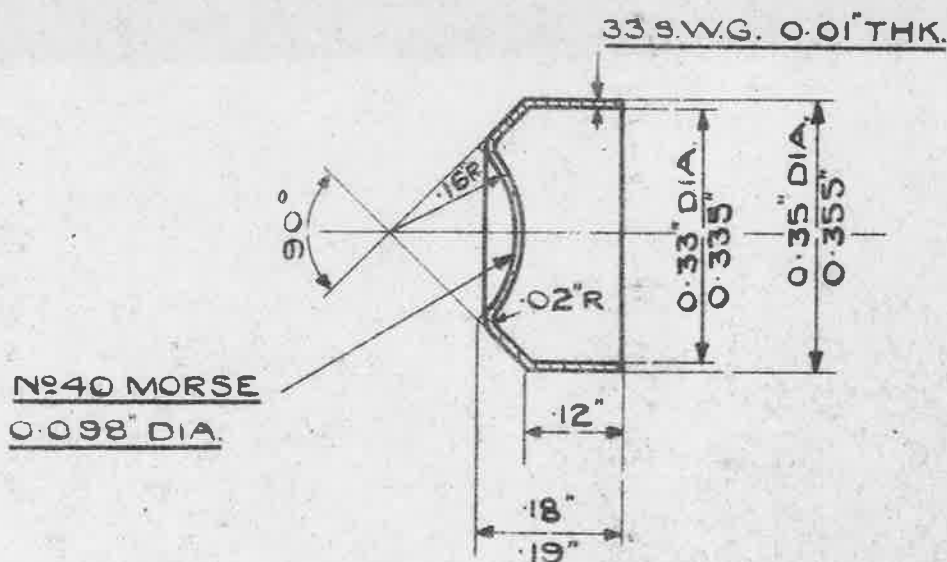

Nº40 MORSE
0.098" DIA.

SCALE :- $\frac{4}{1}$

MATERIAL :- BRASS, B.S. SPEC: 265 (LATEST ISSUE)

FINISH :- ELECTRO - TIN TO SPEC: D.T.D. 924 (LATEST ISSUE).

ISSUED BY ROYAL AIRCRAFT ESTABLISHMENT	TITLE :- THIMBLE FOR CAMBRIC COVERED HT CABLES.					DRAWN FLGOODGER	RETRACED M.HARRIS. 11-1-39
	ISSUE No	1	2	3	4	5	CHECKED G.H. 10.2.25.
ALTERATION No	AGS/63	AGS/86	AS/270	AS/AGS/663	AS/AGS/876		

SM590