

24-3-25  
A.T. PENN

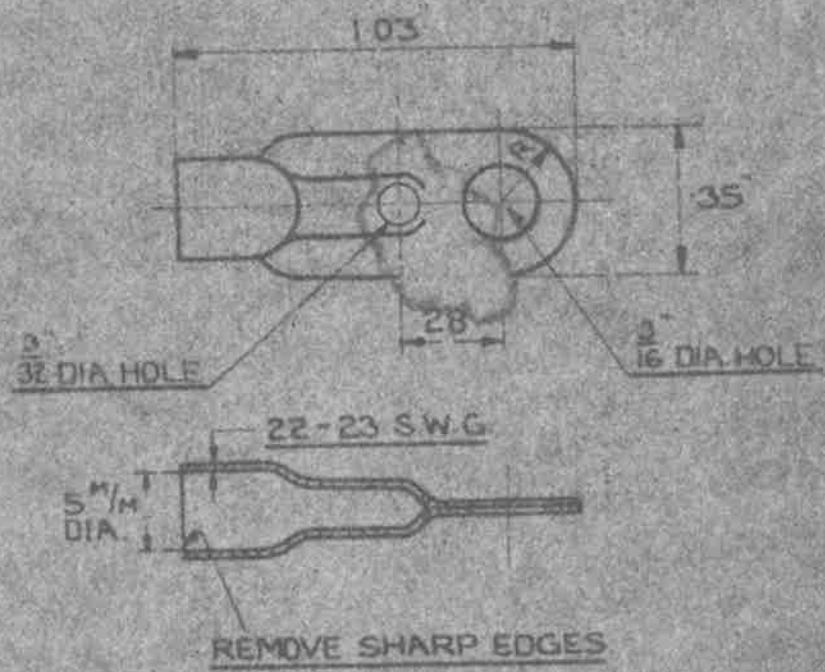

MATERIAL :- TO BE OF BRASS TO BRITISH STANDARD SPECIFICATION 886 (LATEST ISSUE)

FINISH :- TO BE ELECTRO-TINNED, THICKNESS NOT LESS THAN 0002

ISSUED BY DRAWING OFFICE DIRECTORATE OF TECHNICAL DEVELOPMENT AIR MINISTRY	TITLE - 5 M/M CABLE LUGS				DRAWN C. HALL	RE-TRACED A. RICHARDS 10/1/25	
	ISSUE NO	1	2	3	4	CHECKED B. P. HARRIS 10/1/25	APPROVED G. C. BRIDGES 10/1/25
	ALTERATION NO	AGS/63	AD1/63	AD2/63	AD3/63		

**OBSOLESCE** - NOT TO BE USED  
IN NEW DESIGN WORK. SEE S.D.M. 256.

MINISTRY OF  
SUPPLY

AGS.No.1538.

SHEET No 1

NO OF SHEETS. 1

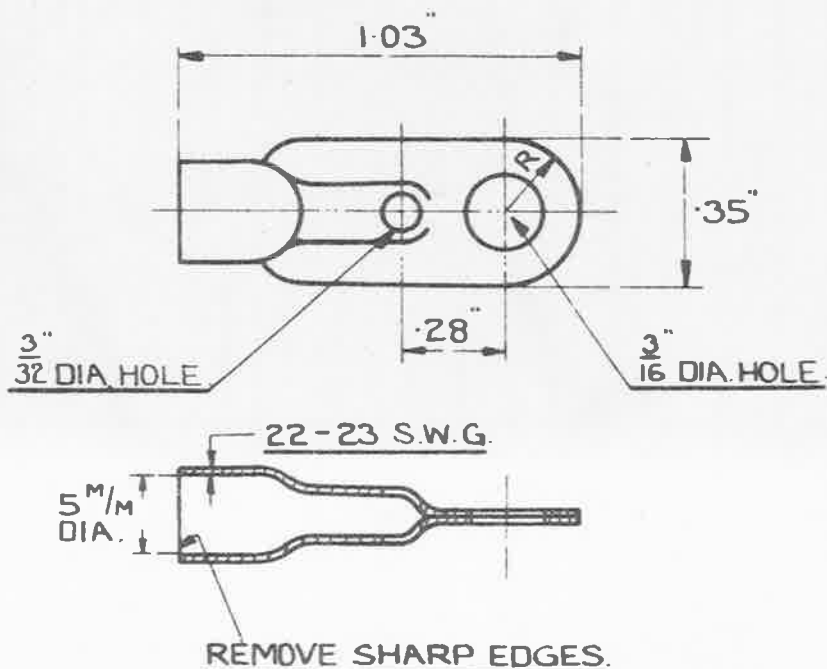

MATERIAL:- TO BE OF BRASS TO BRITISH STANDARD  
SPECIFICATION 886 (LATEST ISSUE)

FINISH:- TO BE ELECTRO-TINNED, THICKNESS NOT LESS THAN .0002"

ISSUED BY  
ROYAL  
AIRCRAFT  
ESTABLISHMENT

TITLE:- 5 M/M GABLE LUGS

DRAWN  
C. HALL.

RE-TRACED  
A. RICHARDSON  
10-1-39.

ISSUE NO	1	2	3	4	5
ALTERATION	AGS/69	AGS/100	AS/AGS/1770	AS/AGS/663	MOD/AGS/973

CHECKED  
H.T. HOAR  
RE-CHECKED  
C.T. ROYAL

APPROVED  
G.E. BAIRSTO  
9-2-25.