

**OBSOLESCE** - NO FURTHER MANUFACTURE -  
EXISTING STOCKS MAY BE USED.

MINISTRY OF  
SUPPLY

ACS No. 1599.

SHEET No. 1

No. OF SHEETS 1

E. S. WIGLEY

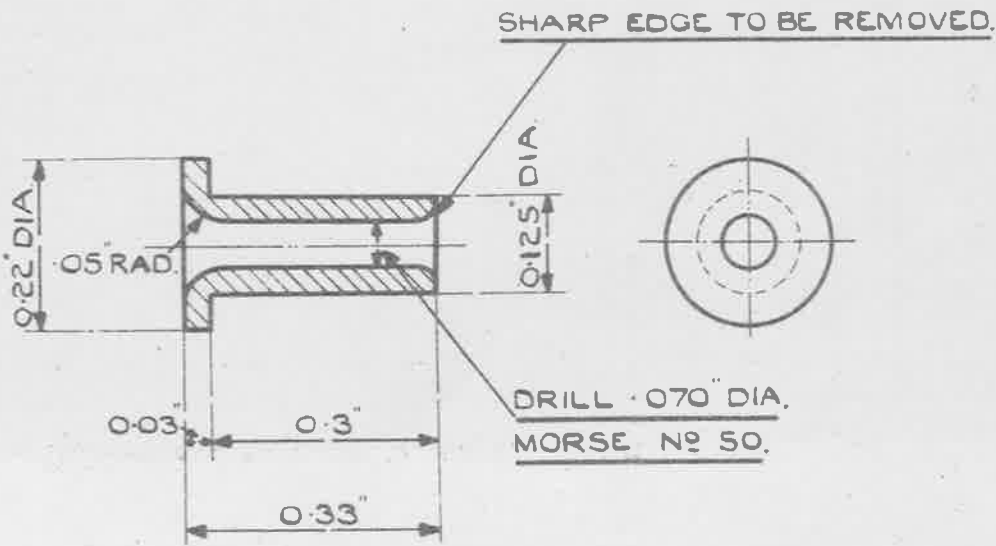

SCALE - 4 TIMES FULL SIZE.

MATERIAL - BRASS TUBE, COMMERCIAL QUALITY.

FINISH - TO BE ELECTRO-TINNED, THICKNESS NOT LESS THAN .0003".

NOTE - PLATING TO BE CARRIED OUT, EITHER BY THE ALKALINE SODIUM STANNATE BATH (WITHOUT ADDITION OF GLUE OR OTHER ORGANIC COMPOUNDS), OR BY THE ACID STANNOUS SULPHATE PROCESS.

ISSUED BY ROYAL AIRCRAFT ESTABLISHMENT	TITLE:- BONDING WIRE SOCKET 5M214.				DRAWN R.L.G.	RE TRACED M.HARRIS 11-1-39	
	ISSUE No	2	3	4 <small>1/2</small>	5	CHECKED R.L.G. 8-3-37. R.S. BASTABLE 12/1/37	APPROVED G.R.W. 1-7-37
	ALTERATION No	ACS/83	ACS No ACS/220	AS/AGS 663	MOD/AGS 1005		

25-8-33.15-7.40

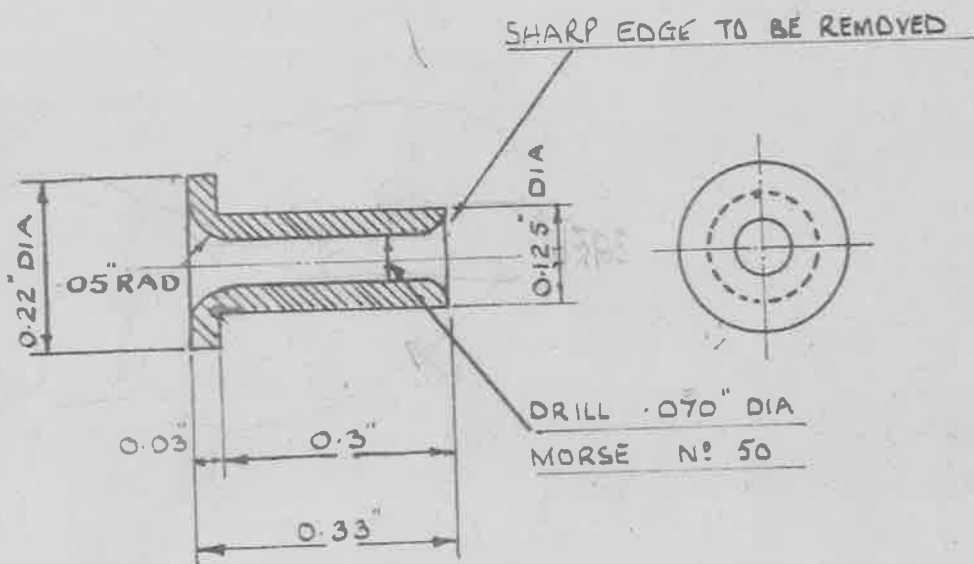

SCALE :- 4 TIMES FULL SIZE

MATERIAL :- BRASS TUBE COMMERCIAL QUALITY

FINISH :- TO BE ELECTRO-TINNED. THICKNESS NOT LESS THAN .0003"

NOTE :- PLATING TO BE CARRIED OUT EITHER BY THE ALKALINE SODIUM STANNATE BATH (WITHOUT ADDITION OF BLUE OR OTHER ORGANIC COMPOUNDS), OR BY THE ACID STANNOUS SULPHATE PROCESS

ISSUED BY ROYAL AIRCRAFT ESTABLISHMENT	TITLE:- BONDING WIRE SOCKET				DRAWN R.L.G.	RE-TRACED DAP.EAF LHP
	ISSUE NO	2 <sup>28</sup> / <sub>35</sub>	3 <sup>45</sup> / <sub>40</sub>	4 <sup>2</sup> / <sub>47</sub>	CHECKED	APPROVED
	ALTERATION NO	AS NO AGS/83	AS NO AGS/20	AS NO AGS/603		