

STORES REF.
No 5K/1596

SCALE $\frac{2}{1}$

8 B.A. EYE (P.O. TAG No 29)

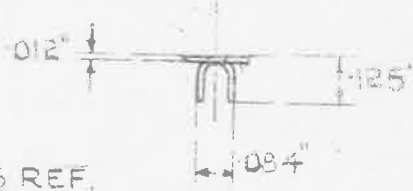
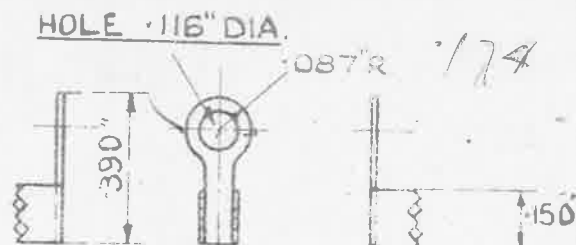

STORES REF.
No 5K/1597

SCALE $\frac{2}{1}$

6 B.A. EYE (P.O. TAG No 30)

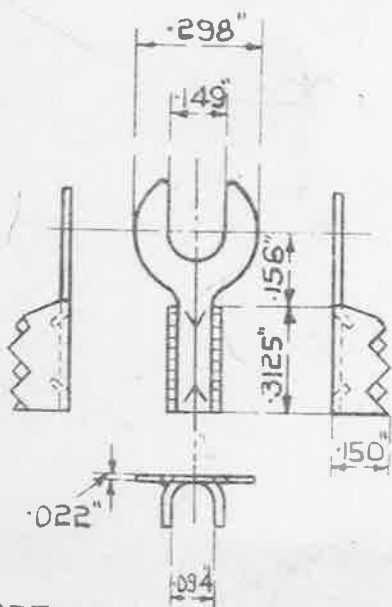

STORES REF.
No 5K/1601

SCALE $\frac{2}{1}$

4 B.A. FORK (P.O. TAG No 31)

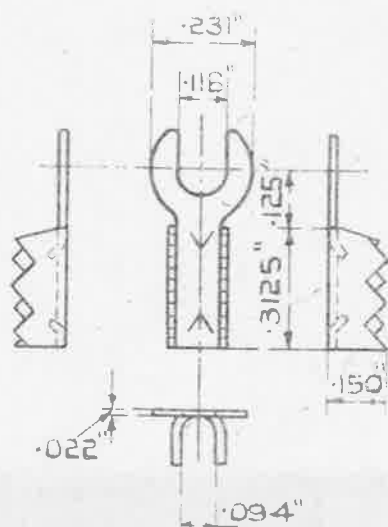

STORES REF.
No 5K/1600

SCALE $\frac{2}{1}$

6 B.A. FORK (P.O. TAG No 32)

MATERIAL:- BRASS, MATT NICKELLED, OR BRIGHT NICKEL SILVER, SOFT.

NOTE:-

POST OFFICE TOOL, INST. No 213. (MARK 234) G.P.O. DRG. 9037. (LATEST ISSUE) TO BE USED FOR CRIMPING TAGS.

NOTE:-

TAGS TO BE MANUFACTURED TO LATEST ISSUE OF POST OFFICE DRG. No 10195A.

THESE ARE POST OFFICE TAGS Nos 29, 30, 31 & 32

ISSUED BY
ROYAL
AIRCRAFT
ESTABLISHMENT

TITLE:- CABLE ENDS, EYE & FORK
TYPE, CHANNEL END,
CRIMPING 4, 6 AND 8 BA

ISSUE No $\frac{2}{1}$ JM. $\frac{2}{1}$ JM. 3
ALTERATION No AGS, AS, AS/AGS

DRAWN
S.F. TUCK

RE-TRACED
J.SPOONER.
10-1-38

CHECKED
P. MILLER
RE-CHECKED
C.E. 25-8-34

APPROVED
G.W. 25-8-34

OBSOLESCE - NOT TO BE USED
IN NEW DESIGN WORK. SEE S.D.M. 256

MINISTRY OF
SUPPLY

AGS.No.1615

SHEET No 1

No OF SHEETS. 1

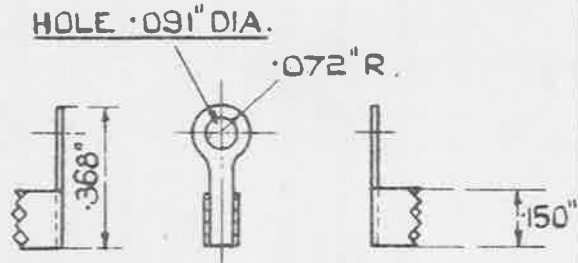

STORES REF.
N° 5K/1596

8 B.A. EYE (P.O. TAG N° 29)

SCALE $\frac{2}{1}$

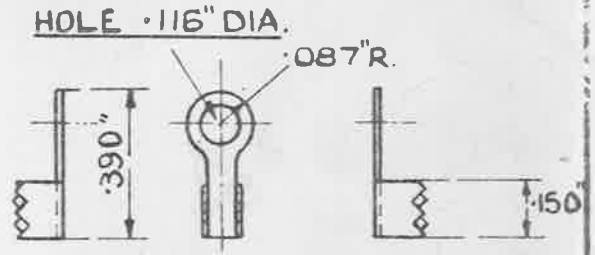

STORES REF.
N° 5K/1597

6 B.A. EYE (P.O. TAG N° 30)

SCALE $\frac{2}{1}$

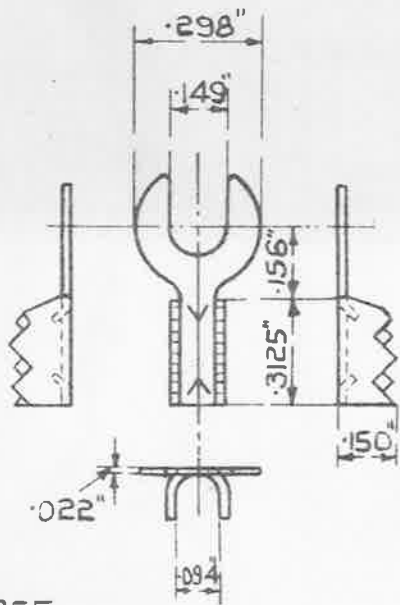

STORES REF.
N° 5K/1601

4 B.A. FORK (P.O. TAG N° 31)

SCALE $\frac{2}{1}$

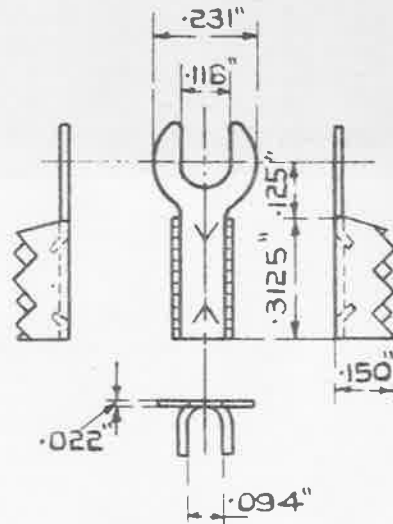

STORES REF.
N° 5K/1600

6 B.A. FORK (P.O. TAG N° 32)

SCALE $\frac{2}{1}$

MATERIAL:- BRASS, MATT NICKELLED, OR BRIGHT NICKEL SILVER, SOFT.

NOTE:-

POST OFFICE TOOL, INST. N° 213. (MARK 234) G.P.O. DRG. 9037.
(LATEST ISSUE) TO BE USED FOR CRIMPING TAGS.

NOTE:-

TAGS TO BE MANUFACTURED TO LATEST ISSUE
OF POST OFFICE DRG. N° 10195A.
THESE ARE POST OFFICE TAGS N°S 29, 30, 31 & 32

ISSUED BY
ROYAL
AIRCRAFT
ESTABLISHMENT

TITLE:- CABLE ENDS, EYE & FORK
TYPE, CHANNEL END,
CRIMPING 4, 6 AND 8 B.A.

ISSUE N°	1	2	3	4
BY	J.M.	J.M.	J.M.	J.M.
DATE	AS/1	AS/AGS	MOO/AGS	SM 779

DRAWN
J.F. TUCK.

CHECKED
F. MILLER

RE-TRACED
J. SPOONER.
10-1-39

APPROVED
G.W. 25-8-34