

# OBSOLESCE

ITEMS MARKED \* - NO FURTHER MANUFACTURE.  
EXISTING STOCKS MAY BE USED.  
ITEMS UNMARKED - NOT TO BE USED FOR NEW  
DESIGNS.

MINISTRY OF  
SUPPLY.

A.G.S. N°1652

SHEET N° 1.

N° OF SHEETS 1.

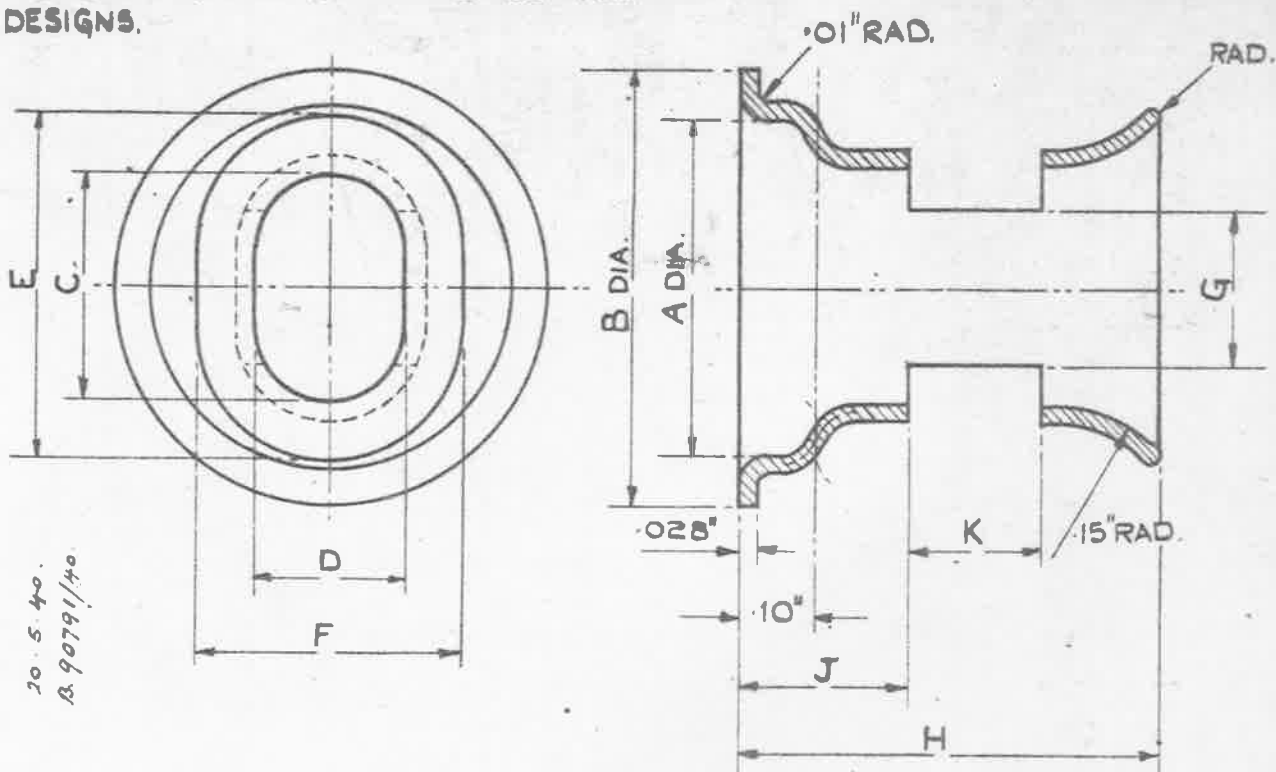

10.5.40.  
B.90791/40

EDGES MUST BE FREE FROM BURRS.

STORES REF. N°	MARK.	A	B	C	D	E	F	G	H	J	K
		+ .005" - .005"	+ .005" - .005"	+ .005" - .005"	+ .005" - .005"	+ .005" - .005"	+ .005" - .005"	+ .005" - .005"	+ .005" - .005"	+ .005" - .005"	+ .005" - .005"
5K/36	1	.430"	.560"	.280"	.190"	.380"	.290"	.180"	.550"	.20"	.20"
5K/37	2 *	.430"	.560"	.310"	.210"	.400"	.300"	.180"	.550"	.20"	.20"
5K/38	3	.430"	.560"	.380"	.240"	.460"	.320"	.250"	.550"	.20"	.20"
5K/39	4	.720"	.90"	.600"	.350"	.700"	.450"	.450"	.750"	.30"	.250"
5K/2611	5 *	1.10"	1.25"	.98"	.57"	1.12"	.71"	.75"	1.00"	.35"	.30"
5K/2824	6 *	.43"	.56"	.27"	.16"	.36"	.25"	NO SLOT	.55"	NO SLOT	
5K/2825	7	.54"	.67"	.44"	.24"	.54"	.34"	.25"	.55"	.20"	.20"

MAT<sup>l</sup> :- BRASS TUBE TO B.S. SPEC. 886 (LATEST ISSUE), OR  
BRASS SHEET, (22 S.W.G) TO B.S. SPEC. 265, (LATEST ISSUE),  
ANNEALED, OR B.S. SPEC. 267, (LATEST ISSUE), ANNEALED.

FINISH:- ELECTRO-TINNED, TO SPEC. D.T.D. 924 (LATEST ISSUE)

RE -

MINISTRY OF SUPPLY  
APPLICATIONS FOR A.G.S.  
SHEETS TO A.T.P. 4,  
CHESSINGTON, SURREY.  
GENERAL ENQUIRIES TO  
A.D/S.A.E., ST GILES COURT,  
1-13 ST GILES HIGH STREET,  
LONDON, W.C. 2.

TITLE:- SLEEVES, PLAIN CABLE  
L.T. TYPE 1, OVAL, N° 1.

DRAWN  
From Sketch N°  
E & I. 8253

TRACED  
S.A.J.  
13<sup>th</sup> OCT '46

ISSUE N° 10  
ALTERN. N° 942

CHECKED  
G.T. Reynolds 26  
R.R. 22.10.46 2  
2.11.46 39

APPROVED  
G.E.B.  
18.3.40

