

OBSOLESCE-NO FURTHER MANUFACTURE.
EXISTING STOCKS MAY BE USED.

MINISTRY OF
SUPPLY

AGS. No 1657.

SHEET No 1 | No OF SHEETS 1

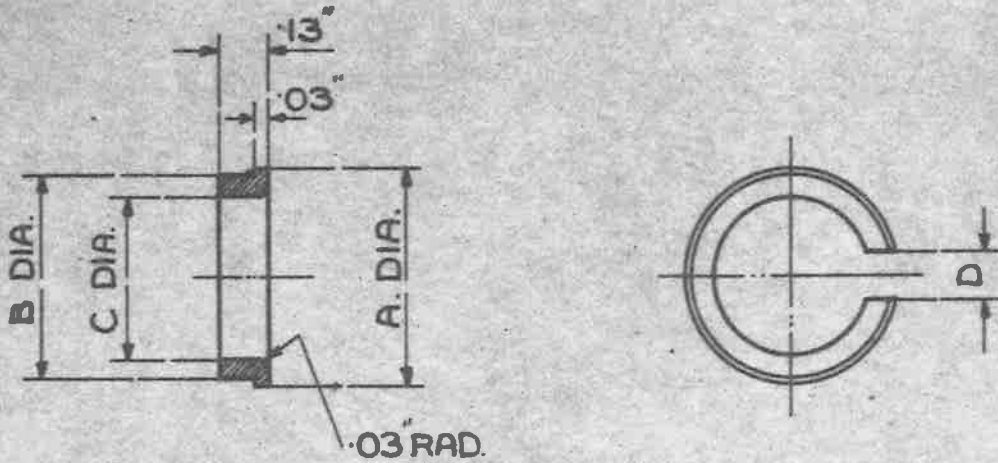

STORES REF. No	MARK.	A	B	C	D
		$\pm .005$ "	$\pm .005$ "	$\pm .005$ "	$\pm .005$ "
5K/86	0	$\begin{matrix} .56 \\ \pm .005 \\ \text{---} \\ 0 \end{matrix}$ "	$\begin{matrix} .53 \\ \pm .002 \\ \text{---} \\ 0 \end{matrix}$ "	$\begin{matrix} .41 \\ \pm .004 \\ \text{---} \\ 0 \end{matrix}$ "	.128"
5K/79	1	.680"	.58"	.54"	.37"
5K/80	2	.80"	.71"	.59"	.37"
5K/81	3	.90"	.80"	.68"	.44"
5K/82	4	1.02"	.93"	.78"	.56"
5K/83	5	1.15"	1.05"	.87"	.62"
5K/84	6	1.25"	1.18"	1.00"	.68"
5K/85	7	1.33"	1.25"	1.12"	.75"
5K/2710	8	$\begin{matrix} .56 \\ \pm .005 \\ \text{---} \\ 0 \end{matrix}$ "	$\begin{matrix} .53 \\ \pm .002 \\ \text{---} \\ 0 \end{matrix}$ "	$\begin{matrix} .41 \\ \pm .004 \\ \text{---} \\ 0 \end{matrix}$ "	.28"

NOTE:-
THE TOLERANCES
FOR A, B & C, DONOT
APPLY TO MK: 0, AND
MK: 8.

MATL: MILD STEEL.

FINISH: TO BE CADMIUM PLATED TO SPEC: D.T.D. 904 (LATEST ISSUE)

ISSUED BY ROYAL AIRCRAFT ESTABLISHMENT	TITLE:- COLLET.			DRAWN FROM SKETCH N E.I. 8258.	TRACED M. HILLMAN 20-9-38
	ISSUE No	8	SM 8/2	CHECKED C.T. Reynolds	APPROVED.
	ALTERS No				

18.2.40

MARK	A	B	C	D
	$\pm .005$	$\pm .005$	$\pm .005$	$\pm .005$
0	.565 .560	.532 .530	.410 .414	.128
1	.68	.58	.54	.37
2	.80	.71	.59	.37
3	.90	.80	.68	.44
4	1.02	.93	.78	.56
5	1.15	1.05	.87	.62
6	1.25	1.18	1.00	.68
7	1.33	1.25	1.12	.75
8	.565 .560	.532 .530	.410 .414	.28

NOTE:-
THE TOLERANCES
FOR A,B,C, DO NOT
APPLY TO MK. 0
OR TO MK. 8.

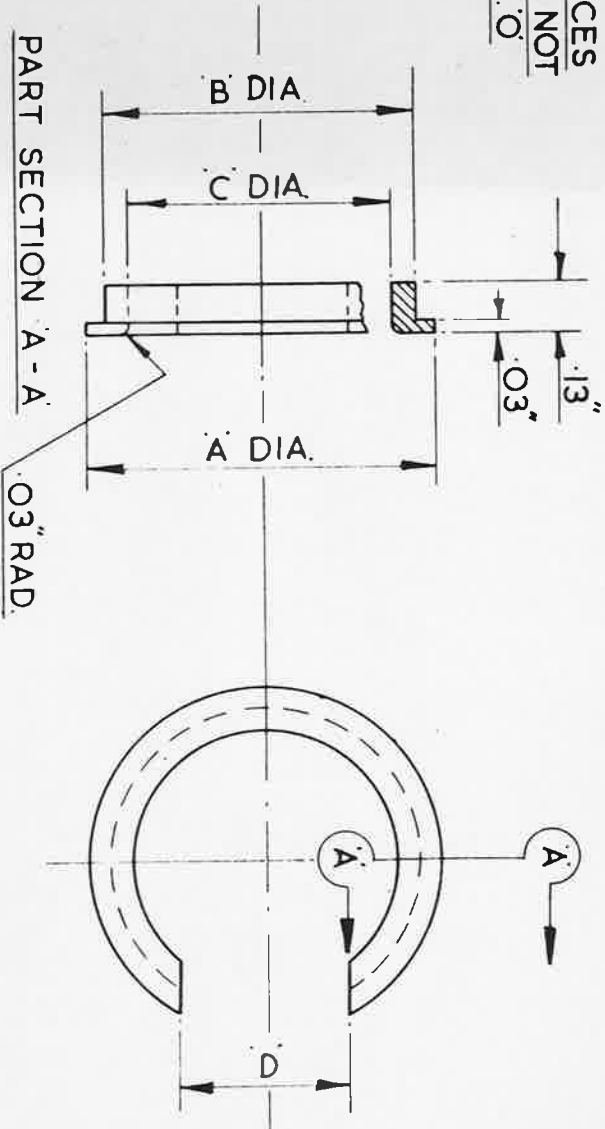

SM 1097

NOTE:-
NOT TO BE USED ON NEW DESIGNS OF
EQUIPMENT (SEE S.D.M. (A) 313)

USED ON	DESIGNED	DRAWN	TRACED	CHECKED	APPROVED FOR S.B.A.C.	DATE	REF	DRAWING OR PART No.	DESCRIPTION	LIMITS NOT SHOWN	A ¹ DRAWN UNIT	OPP HAND QTY	MATERIAL - REMARKS
	F.A.L.	F.A.L.	F.A.L.	F.A.L.	<i>S. B. A. C.</i>	7.5.05			MILD STEEL				BS 970 EN 1A OR B OR BS 1449 EN 2B.
													THIRD ANGLE PROJECTION.

ISSUED BY THE SOCIETY OF BRITISH AIRCRAFT CONSTRUCTORS LTD.,
29, KING STREET, ST. JAMES'S, LONDON, S.W. 1.

COLLET.
A.G.S. 1657.

ISSUE No.	ALT. No.
8	F106