

20-3-40  
B.90791/40

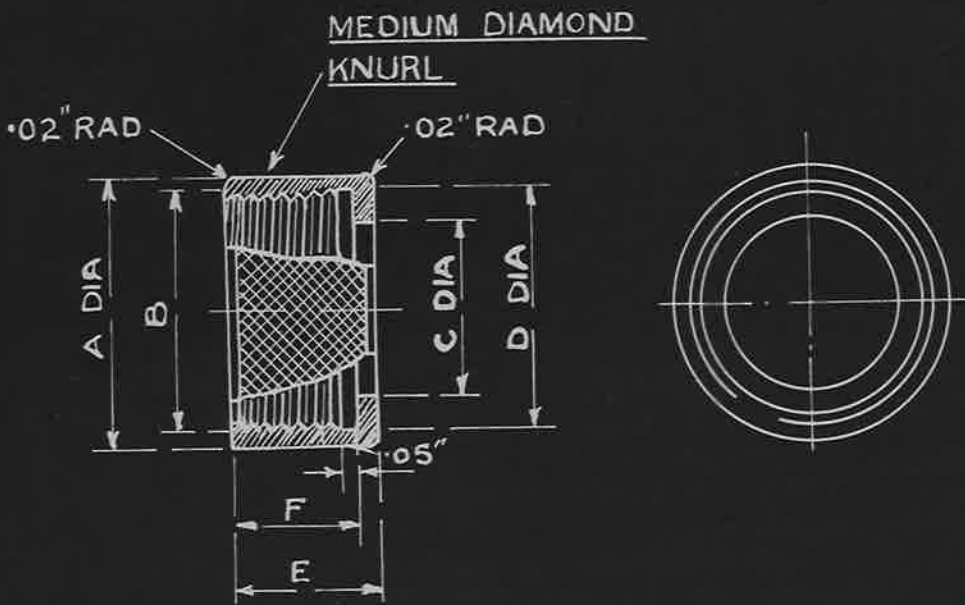

NOTE:- THREAD TO CONFORM WITH B.S. REPORT N°84.

MARK	B		C	D	E	F
	A	DIA. T.P.I.				
	±.005"		±.005"	±.005"	±.005"	±.005"
1	.850"	.750" 26	.50"	.770"	.370"	.320"
2	.950"	.875" 26	.625"	.90"	.370"	.320"
3	1.10"	1.00" 16	.70"	1.02"	.370"	.320"
4	1.20"	1.125" 16	.80"	1.13"	.50"	.450"
5	1.35"	1.25" 16	.90"	1.26"	.50"	.450"
6	1.46"	1.375" 16	1.03"	1.38"	.50"	.450"
7	1.55"	1.437" 16	1.18"	1.44"	.50"	.450"
8						
9						

MAT: STEEL. BEST COMMERCIAL QUALITY.

FINISH:- CADMIUM PLATED

ISSUED BY DRAWING OFFICE DIRECTORATE OF TECHNICAL DEVELOPMENT AIR MINISTRY	TITLE— GLAND NUT FOR USE WITH COLLET.		RETRACTED FOR A.P.C. F.A.S. Public Works Dept. C.A.S. 13/1/40	DRAWN FROM SKETCH E&I 8255	TRACED M. HILLMAN 21-9-39
	ISSUE No. 1	MoD No. AGS/384		CHECKED CT Reynolds 1/29	APPROVED G.S. 16 3/40
ALTERATION	2.6 5-40				