

Obsolete

AIR MINISTRY AGS N° 166

SHEET N° 1 N° OF SHEETS 1

CLIP MADE FROM BRASS
COMMERCIAL QUALITY

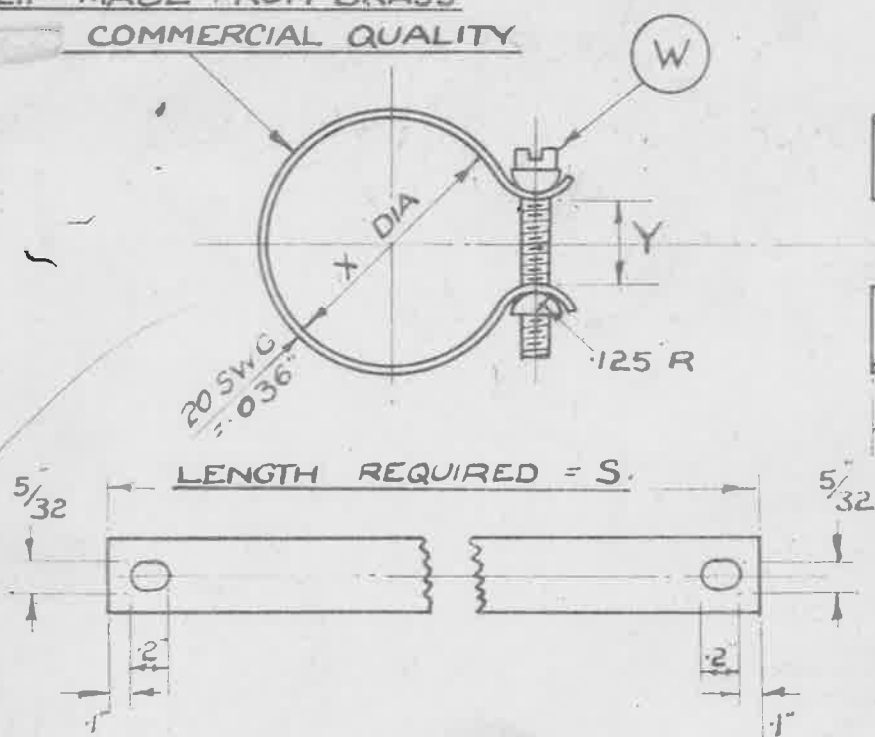

DRILL $\frac{5}{32}$ DIA

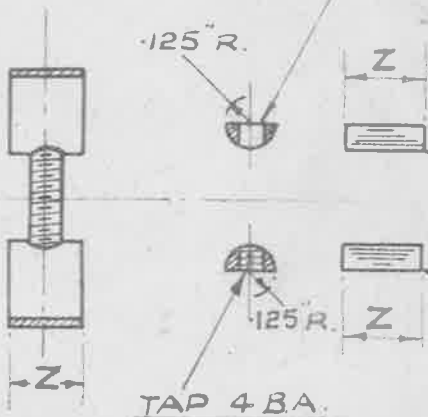

TAP 4 BA.

THESE TWO PARTS MADE FROM M.S. TO B.S. SPEC S.21 (LATEST ISSUE)

MARK	X	Y (APPROX)	Z	W	S
A	.50"	.2"	.31"	AGS.247-24	2.00"
B	.63"	.2"	.31"	AGS.247-24	2.36"
C	.75"	.2"	.31"	AGS.247-24	2.64"
D	.88"	.2"	.31"	AGS.247-24	3.04"
E	1.0"	.2"	.31"	AGS.247-24	3.40"
F	1.13"	.3"	.38"	AGS.247-25	3.90"
G	1.25"	.45"	.38"	AGS.247-26	4.10"
H	1.50"	.45"	.38"	AGS.247-26	4.85"
J	1.75"	.45"	.38"	AGS.247-26	5.70"
K	2.0"	.45"	.38"	AGS.247-26	6.56"
L	2.25"	.45"	.38"	AGS.247-26	7.20"
M	2.50"	.45"	.38"	AGS.247-26	8.00"
N	2.75"	.45"	.38"	AGS.247-26	8.80"
P					
Q					
R					

FINISH (BRASS) TO BE ELECTRO-TINNED, THICKNESS NOT LESS THAN .0002"

FINISH (STEEL) TO BE GALVANIZED TO SPEC. S.T.S. 904. (LATEST ISSUE).

SCREW THREADS :- BRITISH ASSOCIATION (B.A.) TO B.S. SPEC N. N° 93

ISSUED BY DRAWING OFFICE DIRECTORATE OF TECHNICAL DEVELOPMENT MINISTRY OF AIRCRAFT PRODUCTION	TITLE - WATER PIPE BONDING CLIP. (BRASS)					DRAWN	RE-TRACED 4.11.44
	ISSUE N°	1	2	3	4	CHECKED	E. MAITLAND
	ALTER N°	MOD N°	HOL N°	AMEND	AMEND	APPROVED	APPROVED
	AGS/401	AGS/104	AGS/267	AGS/309	AGS/303		

OBSOLESCE - NOT TO BE USED
IN NEW DESIGN WORK. SEE S.D.M. 265.

MINISTRY OF
SUPPLY

A.G.S. N° 1661

SHEET N° 1

N° OF SHEETS 1

CLIP MADE FROM BRASS.

COMMERCIAL QUALITY

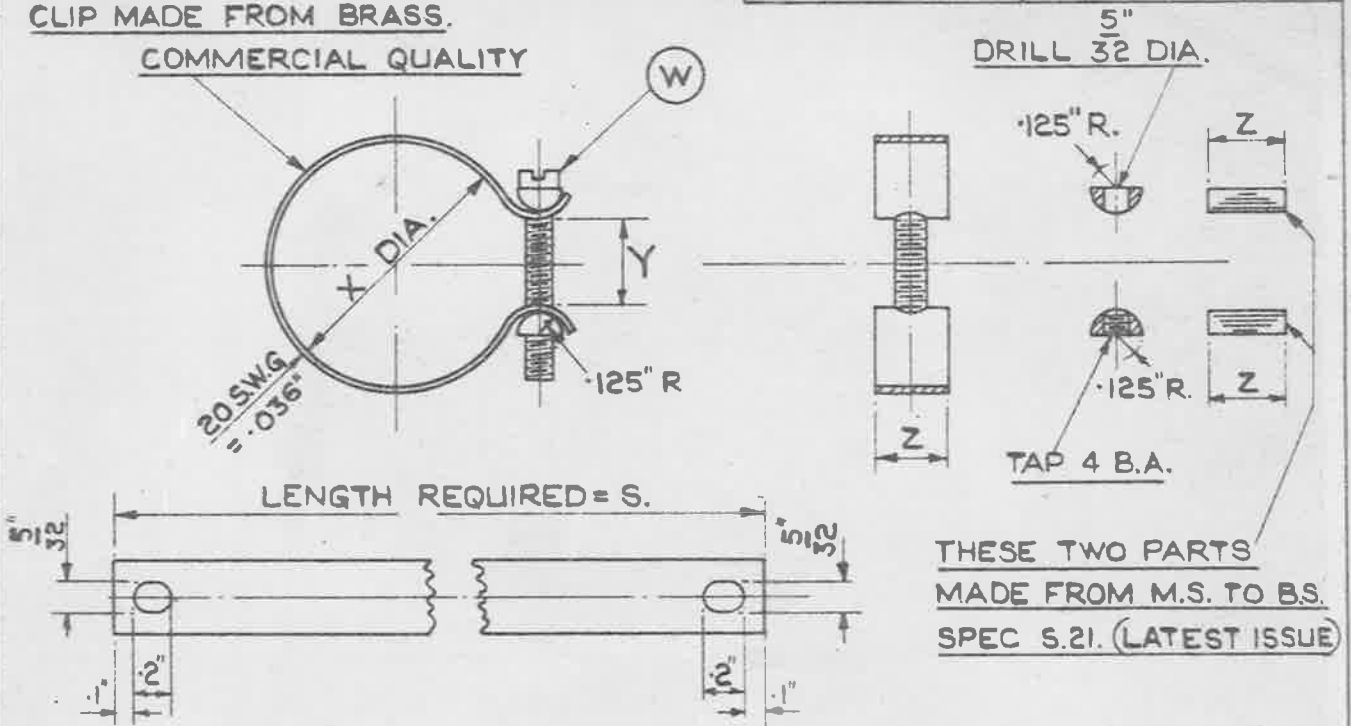

THESE TWO PARTS
MADE FROM M.S. TO B.S.
SPEC S.21. (LATEST ISSUE)

MARK	X	Y APPROX	Z	W	S
A	.50"	.2"	.31"	A.G.S.247-24	2.00"
B	.63"	.2"	.31"	A.G.S.247-24	2.36"
C	.75"	.2"	.31"	A.G.S.247-24	2.64"
D	.88"	.2"	.31"	A.G.S.247-24	3.04"
E	1.0"	.2"	.31"	A.G.S.247-24	3.40"
F	1.13"	.3"	.38"	A.G.S.247-25	3.90"
G	1.25"	.45"	.38"	A.G.S.247-26	4.10"
H	1.50"	.45"	.38"	A.G.S.247-26	4.85"
J	1.75"	.45"	.38"	A.G.S.247-26	5.70"
K	2.0"	.45"	.38"	A.G.S.247-26	6.56"
L	2.25"	.45"	.38"	A.G.S.247-26	7.20"
M	2.50"	.45"	.38"	A.G.S.247-26	8.00"
N	2.75"	.45"	.38"	A.G.S.247-26	8.80"
P					
Q					
R					

FINISH (BRASS) TO BE
ELECTRO-TINNED,
THICKNESS NOT LESS
THAN .0002"

FINISH (STEEL) TO BE
CADMIUM PLATED TO
SPEC: D.T.D. 904
(LATEST ISSUE)

13.10.40
B.157022/40

SCREW THREADS:- BRITISH ASSOCIATION (B.A.) TO B.S. SPEC N° 93

ISSUED BY THE ROYAL AIRCRAFT ESTABLISHMENT	TITLE:- WATER PIPE BONDING CLIP (BRASS) SM 781				DRAWN W.P. SNELL	RE-TRACED J.S. 28.10.47	
	ISSUE N°	5	30	47	6	CHECKED J.H. MILLS	APPROVED G.R.W.
	ALTERN N°	AS/AGS 663	MOD/ACS 975			Re Ch. C.T. Reynolds	11.9.40