

MARK A

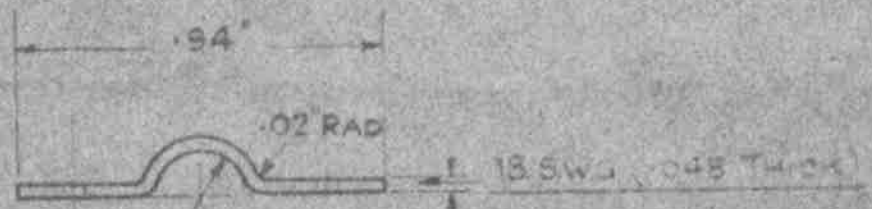

DEVELOPED LENGTH = 1.20" APPROX.

.052" DIA. HOLE (No 55 DRILL)

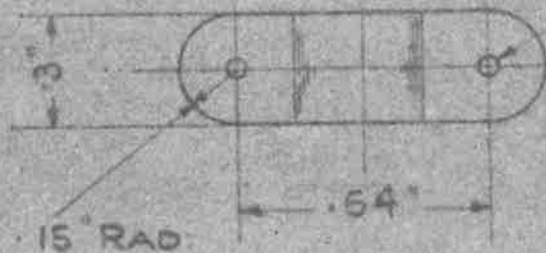

MATERIAL :- ALUMINIUM TO B.S SPEC: L.17 (LATEST ISSUE)

FINISH ~ NATURAL  
CLEAT, WIRING, No 12, REF No 5K/221 (SECURING 1 CABLE OF 6 MM DIAM)

MARK "B"

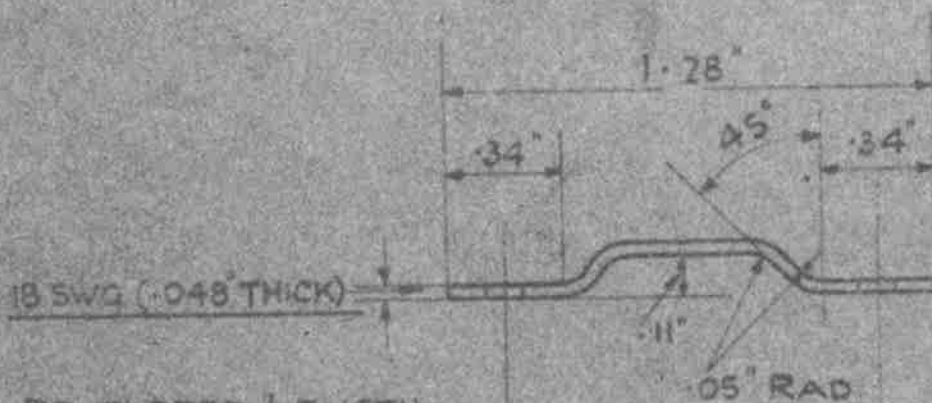

DEVELOPED LENGTH = 1.37" APPROX.

.098" DIA. HOLE (No 40 DRILL)

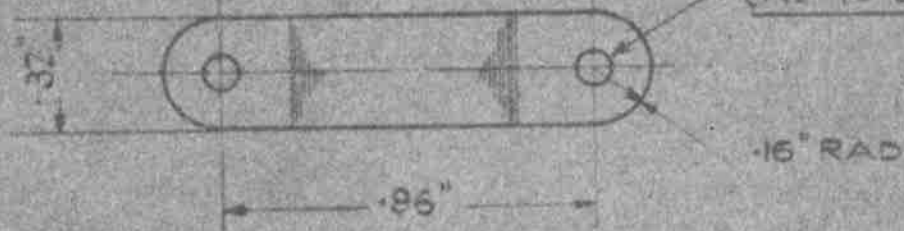

MATERIAL :- ALUMINIUM TO B.S SPEC: L.17 (LATEST ISSUE)

CLEATS, WIRING, No 13, REF No 5K/222 (SECURING 2 CABLES 6 MM DIAM)

FINISH ~ NATURAL

ISSUED BY THE ROYAL AIRCRAFT ESTABLISHMENT	TITLE - CLEATS WIRING, ALUMINIUM, Nos 12 & 13			DRAWN J.E.	TRACED M.C.S. 28940
	ISSUE No	XI	2	CHECKED J.	APPROVED
	ALTERS No	48/705	693		

OBSOLESCE - NOT TO BE USED  
IN NEW DESIGN WORK. SEE S.D.M. 265

MINISTRY OF  
SUPPLY

AGS. NO 1671.

SHEET NO 1 / NO OF SHEETS 1

MARK "A"

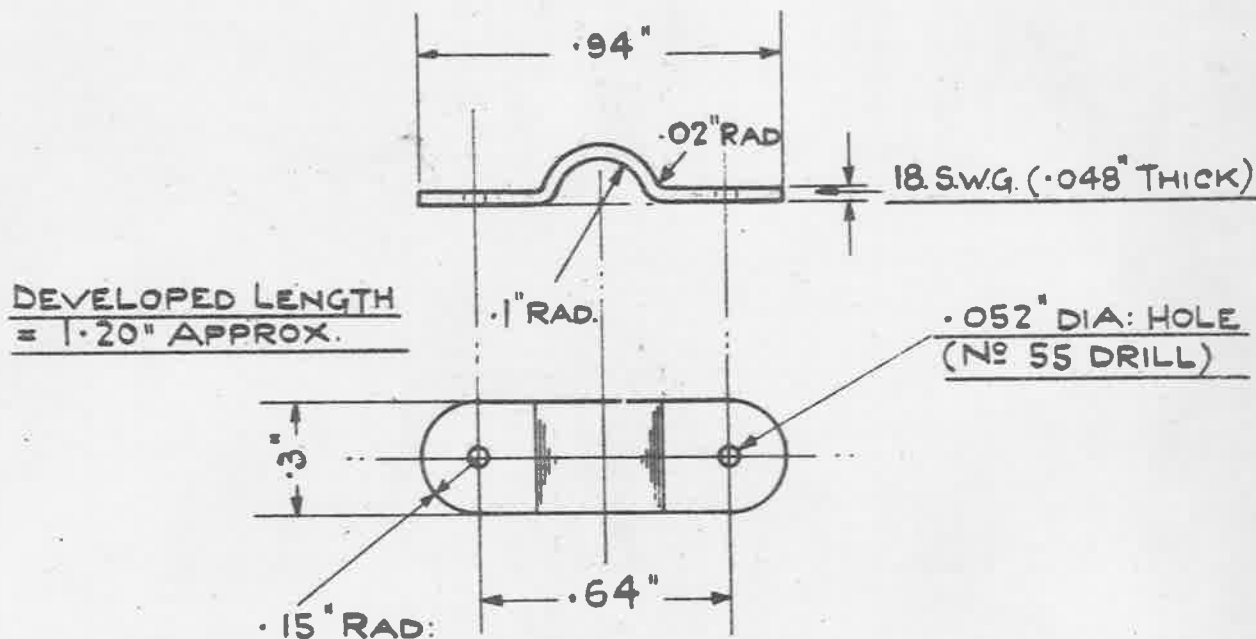

MATERIAL :- ALUMINIUM. TO B.S. SPEC: L.17. (LATEST ISSUE)

FINISH :- NATURAL.

CLEAT, WIRING, NO 12, REF NO 5K/221 (SECURING 1 CABLE OF 6 M.M. DIAM.)

MARK "B"

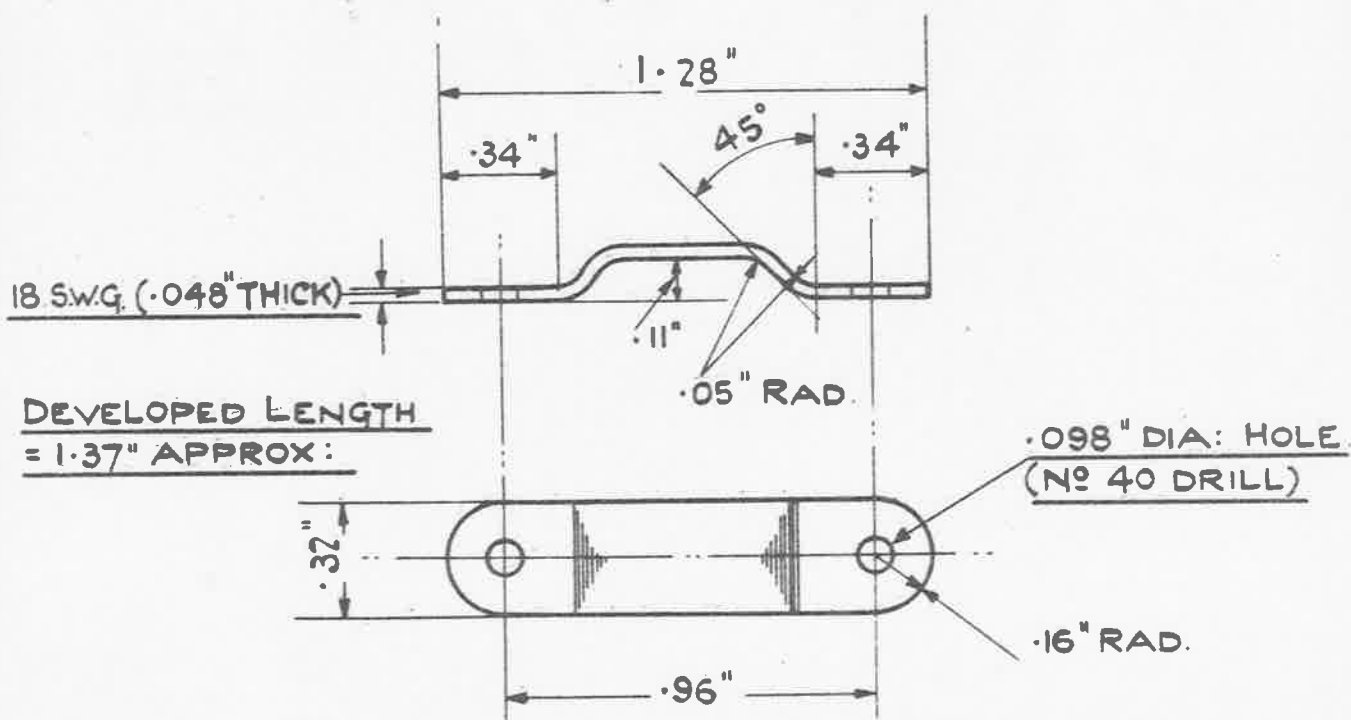

MATERIAL :- ALUMINIUM. TO B.S. SPEC: L.17. (LATEST ISSUE)

CLEATS, WIRING, NO 13, REF. NO 5K/222 (SECURING 2 CABLES 6 M.M. DIAM)

FINISH :- NATURAL.

ISSUED BY THE  
ROYAL  
AIRCRAFT  
ESTABLISHMENT

TITLE:- CLEATS, WIRING,  
ALUMINIUM, NOS 12 & 13.

ISSUE NO	1	2	3
ALTER NO			

DRAWN.

J. E.

TRACED

M.C.S. 28.9.40.

CHECKED

APPROVED.

24/10/40