

13-19-45
RES. A.G.S. 208.

MINISTRY OF
AIRCRAFT
PRODUCTION.

AGS No. 1759.

THIS SUPERSEDES A.G.S. 1707.

SHEET No. 1.

No. OF SHEETS 1.

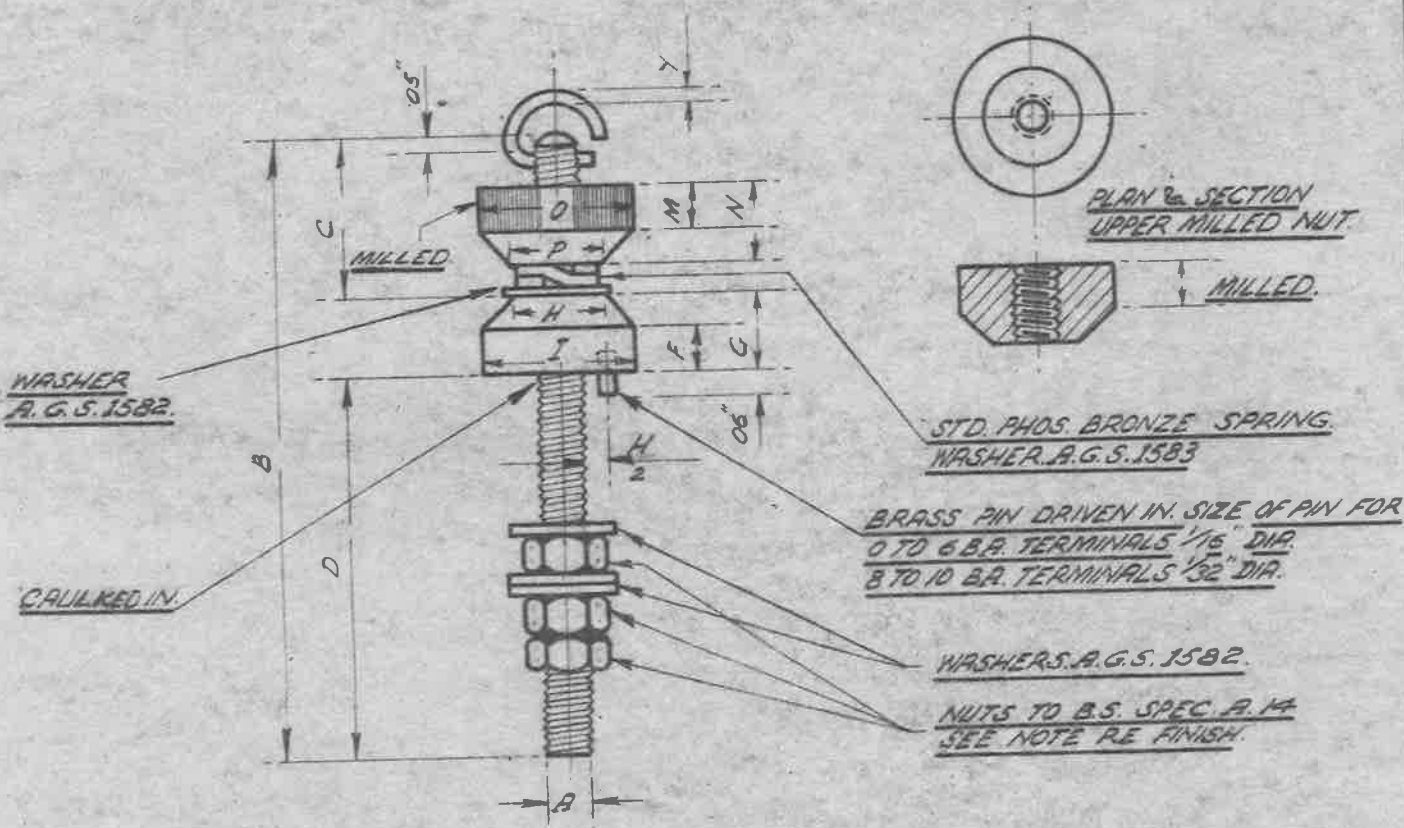

STORES REF. No.	SIZE B.A.	DIMENSIONS.								
		BODY.								
		A	B	C	D	E	F	G	H	I
SK/2698	1/4 B.S.F.	2.60	0.79	1.50		0.20	0.30	0.50	0.75	
SK/2699	2 B.A.	2.54	0.73	1.50		0.20	0.30	0.45	0.70	
SK/2700	4 B.A.	2.15	0.64	1.25		0.15	0.25	0.35	0.55	
SK/2701	6 B.A.	1.75	0.54	1.00		0.12	0.20	0.25	0.40	
SK/2702	8 B.A.	1.35	0.47	0.75		0.09	0.125	0.20	0.25	
SK/2703	10 B.A.	1.00	0.39	0.50		0.05	0.10	0.15	0.20	

	UPPER MILLED NUT.				WASHER	SPRING WASHER	D RING.	NUTS.	
	A	M	N	O	AGS No	A.G.S. No	Y	B.S. SPEC. A 14.	
SK/2698	1/4 B.S.F.	0.20	0.40	0.75	0.50	1582-A	1583-A	18 S.W.G. 048.	E.B.
SK/2699	2 B.A.	0.20	0.35	0.70	0.45	1582-B	1583-B	18 S.W.G. 048	2 B.
SK/2700	4 B.A.	0.15	0.30	0.55	0.35	1582-C	1583-C	20 S.W.G. 036	4 B.
SK/2701	6 B.A.	0.12	0.20	0.40	0.25	1582-D	1583-D	20 S.W.G. 036	6 B.
SK/2702	8 B.A.	0.08	0.14	0.25	0.20	1582-E	1583-E	22 S.W.G. 028	8 B.
SK/2703	10 B.A.	0.05	0.08	0.20	0.15	1582-F	1583-F	24 S.W.G. 022	10 B.

ALL THE ABOVE DIMENSIONS ARE IN INCHES & A TOLERANCE OF ±0.01 INCH WILL BE ALLOWED ALL THROUGH.

SCREW THREADS ARE TO BE IN ACCORDANCE WITH B.S. SPEC. No 93

MATERIAL FOR TERMINAL:- BRASS.

MATERIAL FOR 'D' RING- BRASS WIRE.

FINISH:- ALL ITEMS EXCEPT SPRING WASHERS-A.G.S.1583 ARE TO BE NICKEL PLATED TO AN AVERAGE THICKNESS OF .0002" & INSPECTED TO B.S SPEC. 1224.

ISSUED BY ROYAL AIRCRAFT ESTABLISHMENT.	TITLE:- <u>TERMINALS, INSTRUMENT</u> (SINGLE)				DRAWN.	TRACED. U. MATTHEWS 14. 5. 48.
	ISSUE No.	1			CHECKED.	APPROVED.
	ALTER ⁿ No.	1940. A.G.S. 1759			L COOK	