

ALL DIMENSIONS ARE IN INCHES.

A.G.S. 3018. SHEET I.

MIN. CLEARANCE DIMENSION FOR HEXAGON CORNERS. EXTRA ALLOWANCE SHOULD BE MADE TO CLEAR SPANNERS AS NECESSARY.

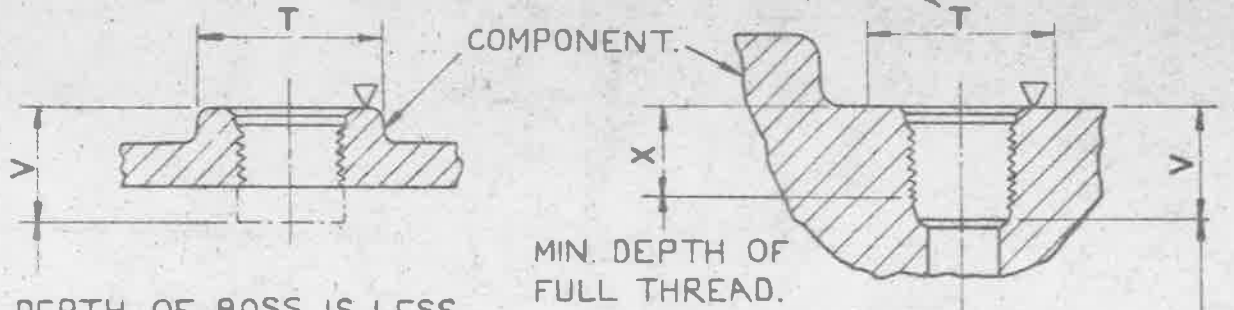

IF DEPTH OF BOSS IS LESS THAN 'V', FITTING CLEARANCE MUST BE PROVIDED.

MIN. DEPTH OF FULL THREAD.

MIN. DEPTH OF TAPPING HOLE.

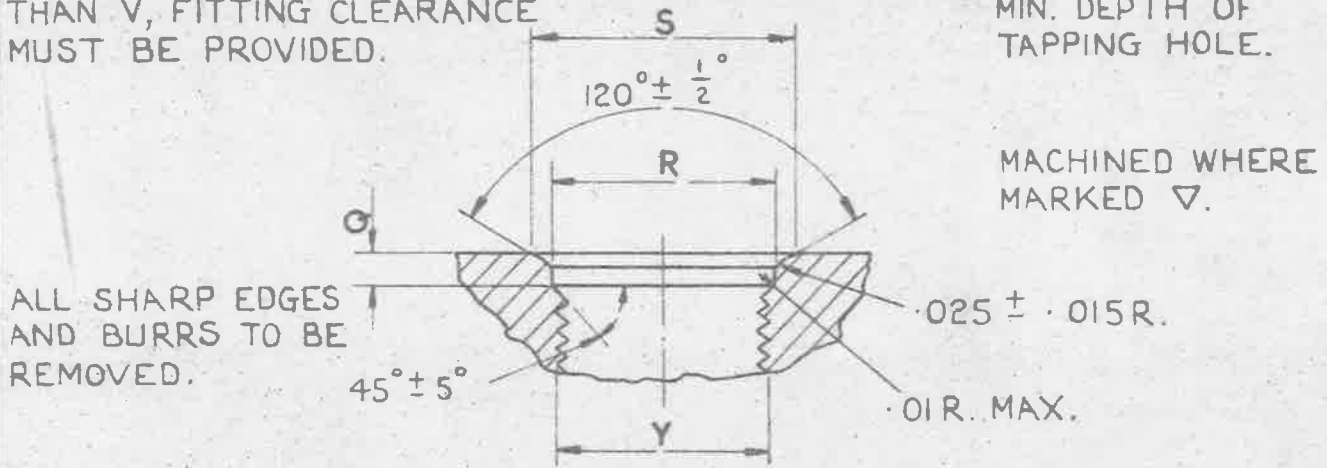

ALL SHARP EDGES AND BURRS TO BE REMOVED.

ENLARGED VIEW OF CHAMFERED COUNTERBORE.

MACHINED SURFACES SHOULD BE NORMAL TO THE AXIS OF THREAD & ALL DIAMETERS CONCENTRIC WITH EACH OTHER TO REASONABLE WORKING TOLERANCES

O/D. OF RIGID PIPE OR I/D. OF FLEXIBLE PIPE TO BE CONNECTED	THREAD Y	X	V	T	S	R	Q
		MIN.	MIN.	MIN.	+ .015 - 0	+ .005 - 0	+ .015 - 0
$\frac{3}{16}$	$\frac{3}{8}$ - 24 U.N.F.	.406	.500	.75	.502	.386	.063
$\frac{1}{4}$	$\frac{7}{16}$ - 20 U.N.F.	.438	.594	.83	.562	.450	.075
$\frac{5}{16}$	$\frac{1}{2}$ - 20 U.N.F.	.438	.594	.90	.625	.513	.075
$\frac{3}{8}$	$\frac{9}{16}$ - 18 U.N.F.	.469	.594	.97	.687	.577	.083
$\frac{7}{16}$	$\frac{5}{8}$ - 18 U.N.F.	.469	.594	1.04			
$\frac{1}{2}$	$\frac{3}{4}$ - 16 U.N.F.	.562	.718	1.19	.875	.767	.094
$\frac{5}{8}$	$\frac{7}{8}$ - 14 U.N.F.	.625	.781	1.33	1.000	.893	.107
$\frac{3}{4}$	$1\frac{1}{16}$ - 12 U.N.S.	.688	.906	1.62	1.237	1.083	.125
$\frac{7}{8}$	$1\frac{3}{16}$ - 12 U.N.S.	.688	.906	1.70			
1	$1\frac{5}{16}$ - 12 U.N.S.	.688	.938	1.92	1.487	1.333	.125
$1\frac{1}{4}$	$1\frac{5}{8}$ - 12 U.N.S.	.688	.984	2.20	1.800	1.646	.125
$1\frac{1}{2}$	$1\frac{7}{8}$ - 12 U.N.S.	.750	1.125	2.50	2.050	1.897	.125
$1\frac{3}{4}$	$2\frac{1}{4}$ - 12 U.N.S.	.812	1.250	2.95	2.425	2.272	.125
2	$2\frac{1}{2}$ - 12 U.N.S.	.938	1.375	3.25	2.675	2.522	.125

NOTE:- THESE DIMENSIONS ARE EQUIVALENT IN ESSENTIAL DETAILS TO THOSE LAID DOWN IN U.S. AERONAUTICAL DESIGN STANDARD AND. 10050. U.N. THREADS TO BE IN ACCORDANCE WITH B.S. SPEC. NO 1580. (LATEST ISSUE) CLASS 2B FIT.

TITLE:- DIMENSIONS OF TAPPED BOSSES WITH UNIFIED THREADS FOR PIPE COUPLING UNION ADAPTORS USING "O" RING (e.g. U.S. AN. 6290. OR EQUIVALENT) GASKETS.

ISSUE	1						
ALT. NO.	MOD/AGS 1018						
R/A E APPROVAL		NUMBER OF SHEETS		A.G.S. NO 3018.			
SIGNATURE	DATE	1		SHEET 1.			
A.D.S.A.E APPROVAL							
SIGNATURE	DATE						

MINISTRY OF SUPPLY
APPLICATIONS FOR A.G.S SHEETS TO:-
A.T.P.4. BLOCK 'E', CHESSINGTON, SURREY.
GENERAL ENQUIRIES TO:-
A.D./S.A.E. ST GILES COURT, 1-13
ST GILES HIGH STREET, LONDON W.C.2