

A.G.S. 3090

ISSUE	REV. NO.	DATE
2	F.152	5/21/48
		11/10/67

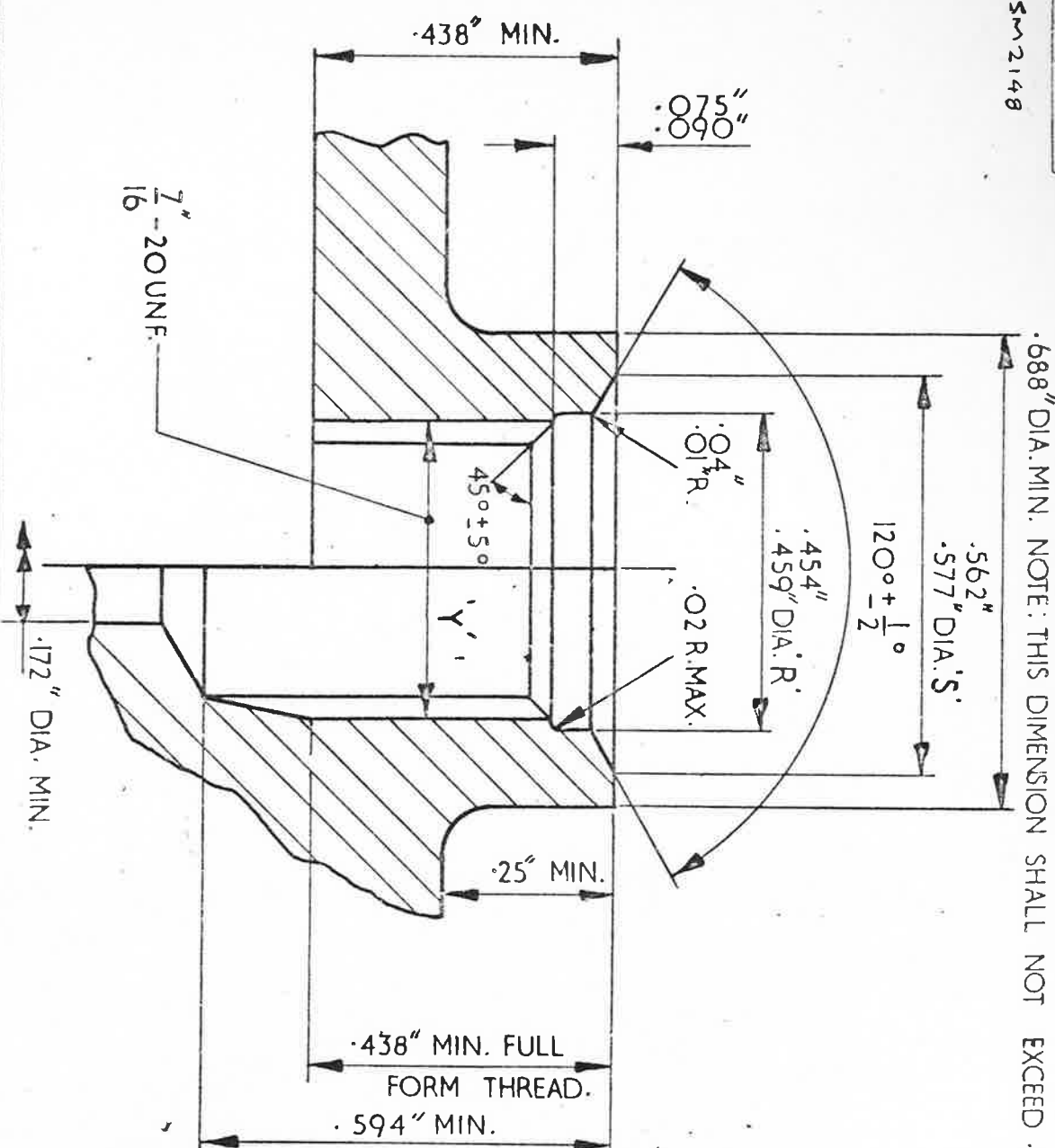

.688" DIA. MIN. NOTE: THIS DIMENSION SHALL NOT EXCEED .740" DIA.

1. CLEARANCE SHALL BE PROVIDED FOR THE USE OF A STANDARD WRENCH.
2. UNF. THREADS TO B.S. SPEC. 1580 CLASS 2 B OF BOSS WHEN MEASURED AT .688 DIA. SHALL BE WITHIN .005" F.I.M.
3. DIA. S.DIA. R. AND THREAD "Y" DIA. SHALL BE CONCENTRIC WITHIN .005" F.I.M.
4. DIMENSIONS OF TAPPED HOLE AGREE WITH A.G.S. 3018.
5. WHEN A TAPPED HOLE IS PROVIDED FOR INSTRUMENT CASE CONNECTIONS (SEE SDM. (A) 15.333) A RAISED BOSS OF A MIN. HEIGHT OF .25" SHALL BE PROVIDED TO GIVE CLEARANCE FOR THE USE OF BANJO CONNECTORS AS. 8679.
6. SURFACE OF BOSS SHALL BE SPOTFACED.
7. THE MINIMUM DIAMETER OF THE BOSS AND DETAILS OF THE TAPPED HOLE ARE IN ACCORDANCE WITH THE REQUIREMENTS OF A.S.C. AIR STANDARD 17/20A

USED ON	DESIGNED	DRAWN	TRACED	CHECKED	APPROVED FOR S.A.C.	PT	SCALE	NOTES SHOWN
		W.H.L.	W.H.L.	W.H.L.	F.H. UNDER CODE 20-51.	PT	4/1	

ISSUED BY THE SOCIETY OF BRITISH AEROSPACE COMPANIES LTD.  
 29, KING STREET, ST. JAMES'S, LONDON, S.W.1.  
 7/16-20 UNF. TAPPED HOLE FOR A.G.S. 3090  
 INSTRUMENT (PRESSURE)