

AGS. 3091

ISSUE NO. 2
 DATE 11.10.67

SM 2148

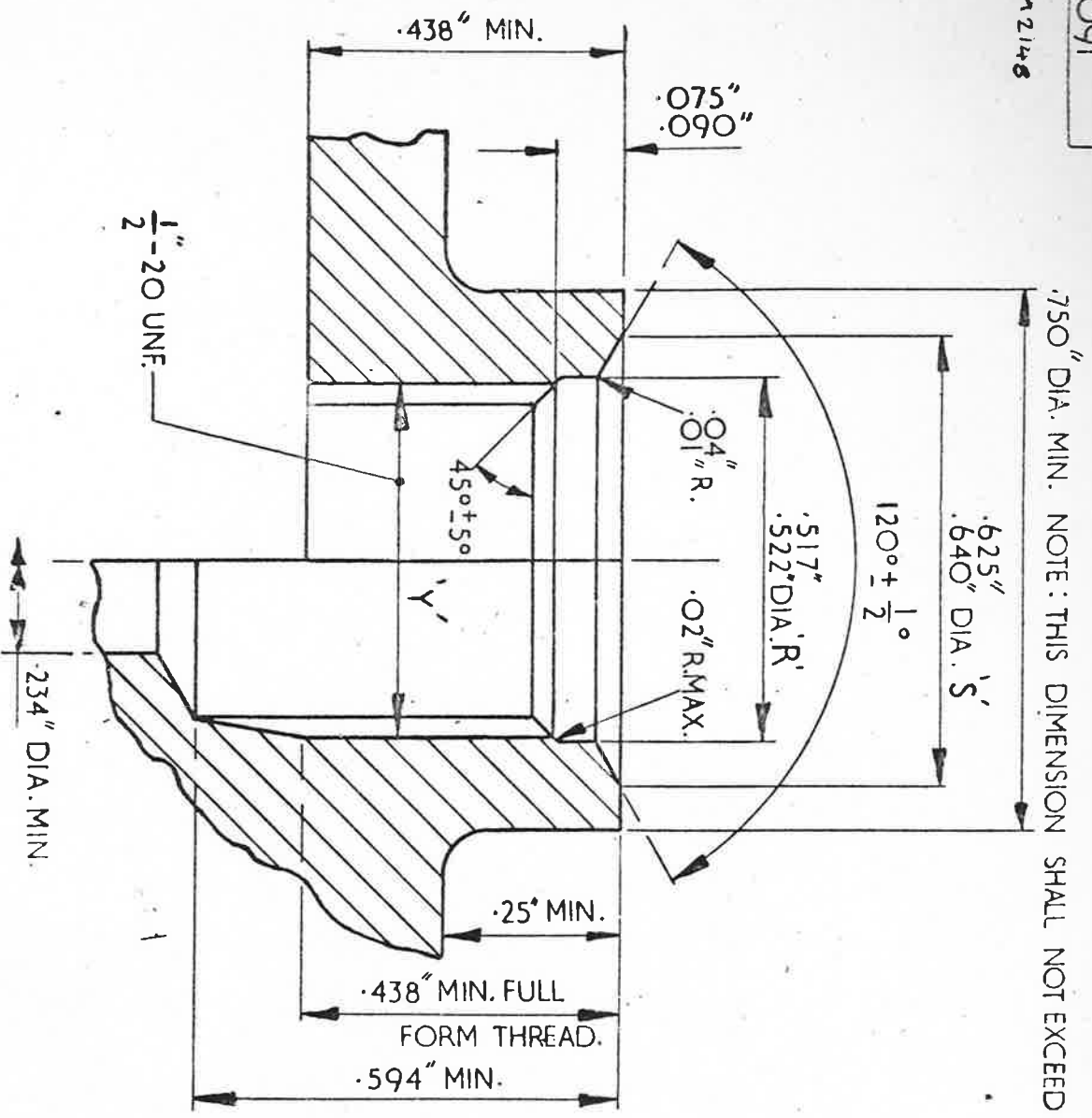

.750" DIA. MIN. NOTE: THIS DIMENSION SHALL NOT EXCEED .800" DIA.

1. CLEARANCE SHALL BE PROVIDED FOR THE USE OF A STANDARD WRENCH.
2. UNF. THREADS TO B.S. SPEC. 1580 CLASS 2 B.
3. SQUARENESS BETWEEN THREAD AND FACE OF BOSS WHEN MEASURED AT .750" DIA. SHALL BE WITHIN .005" F.I.M.
4. DIA. S' DIA. R' AND THREAD Y' DIA. SHALL BE CONCENTRIC WITHIN .005" F.I.M.
5. DIMENSIONS OF TAPPED HOLE AGREE WITH AGS. 3018.
6. WHEN A TAPPED HOLE IS PROVIDED FOR INSTRUMENT CASE CONNECTIONS (SEE SDM.(A) 15.333) A RAISED BOSS OF A MIN. HEIGHT OF .25" SHALL BE PROVIDED TO GIVE CLEARANCE FOR THE USE OF BANJO CONNECTORS AS. 8679.
7. SURFACE OF BOSS SHALL BE SPOTFACED.
8. THE MINIMUM DIAMETER OF THE BOSS AND DETAILS OF THE TAPPED HOLE ARE IN ACCORDANCE WITH THE REQUIREMENTS OF A.S.C.C. AIR STANDARD 17/20A.

DESIGNED	DRAWN	TRACED	CHECKED	APPROVED FOR S.B.A.C.	DATE	PT	SCALE	UNIT NOT SHOWN	
W.H.L.	W.H.L.	W.H.L.	W.H.L.	E.H. UNDERWOOD	20-1-61	PT	4/1		
ISSUED BY THE SOCIETY OF BRITISH AEROSPACE COMPANIES LTD.									
29, KING STREET, ST. JAMES'S, LONDON, S.W. 1.									
					A.G.S. 3091				