

17.10.33
RC4854/33

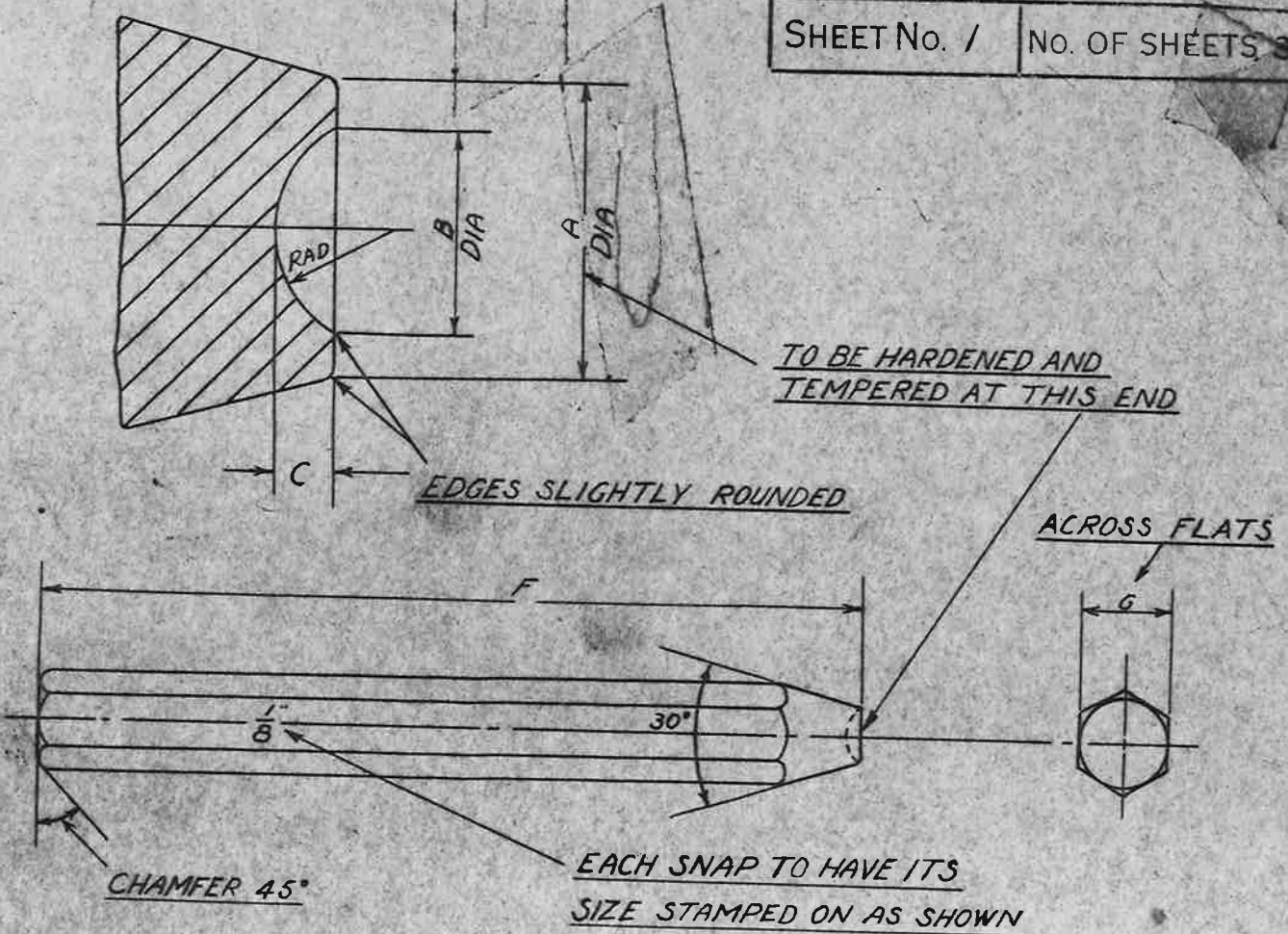

PART No	DIA OF RIVET	A	B	C	F	G
1	1/16	20"	11"	04"	4.5"	445"
2	3/32	28"	16"	06"	4.5"	445"
3	1/8	34"	22"	08"	4.5"	445"
4	5/32	40"	27"	09"	4.5"	445"
5	3/16	44"	33"	11"	5.0"	600"
6	7/32	50"	38"	13"	5.0"	600"
7	1/4	56"	44"	15"	5.0"	600"
8	9/32	62"	49"	17"	5.5"	820"
9	5/16	67"	55"	19"	5.5"	820"
10	11/32	72"	61"	21"	5.5"	820"
11	3/8	78"	66"	23"	5.5"	820"

SPECIFICATION :- THE MATERIAL TO BE TOOL STEEL TO AIR MINISTRY SPECIFICATION N°71 TEMPER N°5. (LATEST ISSUE)

ISSUED BY DRAWING OFFICE DIRECTORATE OF TECHNICAL DEVELOPMENT AIR MINISTRY	TITLE :- SNAP FOR SOLID RIVETS		RETRACED FOR A. P. C.	DRAWN G.HORMSTON	TRACED S.M.B-7-33
	ISSUE No. X	2	3	CHECKED w/Kempell	APPROVED 12-7-33
	ALTERATION AGS/232	AGS/245	AGS/285		
	12-2-31	28-5-X			

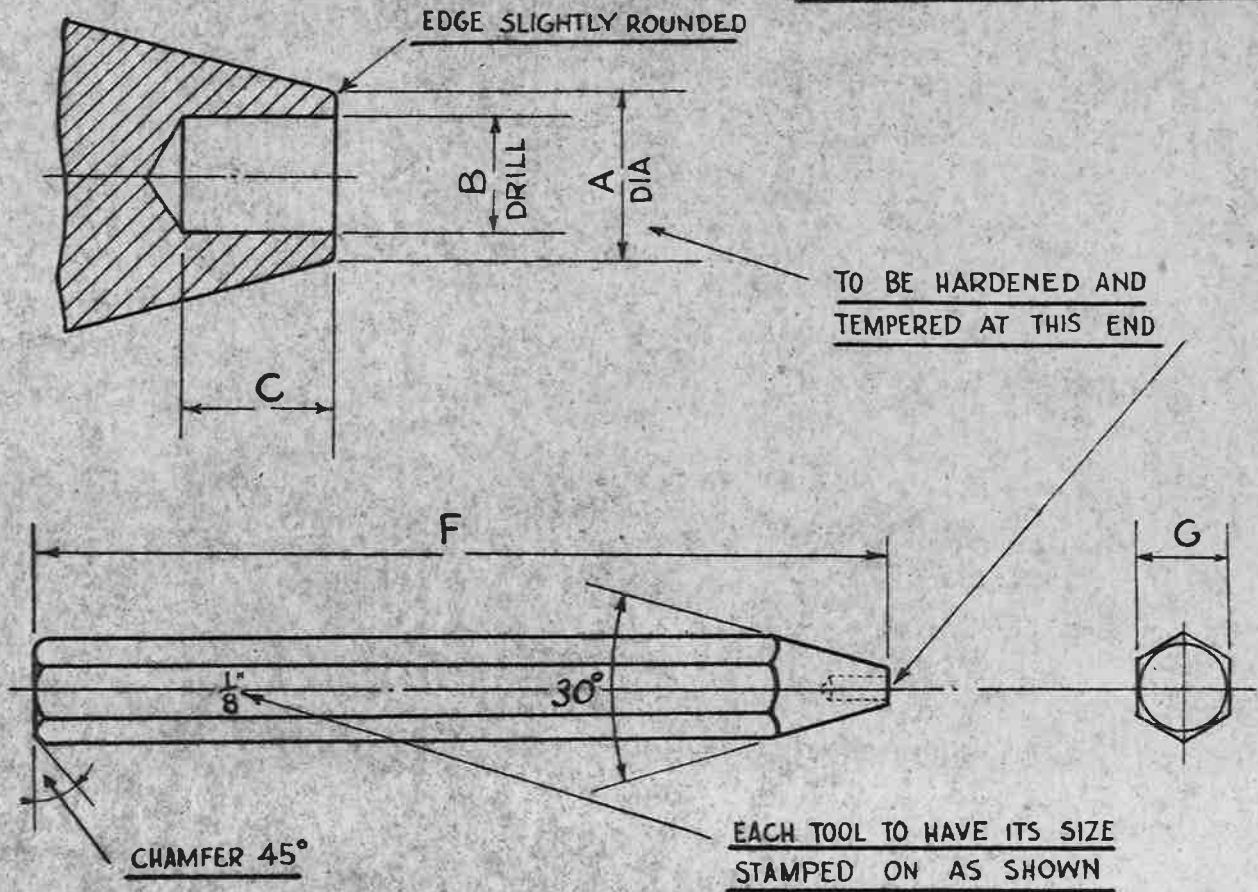

PART N ^o	DIA OF RIVET	A	B	C	F	G
21	1/16	.21	5/64	1"	4.5	.445
22	3/32	.24	7/64	1"	4.5	.445
23	1/8	.28	5/32	1"	4.5	.445
24	5/32	.31	3/16	1"	4.5	.445
25	3/16	.34	7/32	1"	4.5	.445
26	7/32	.37	1/4	1"	4.5	.445
27	1/4	.41	9/32	1.25	4.5	.600
28	5/32	.44	5/16	1.25	4.5	.600
29	5/16	.47	11/32	1.25	4.5	.600
30	11/32	.50	3/8	1.25	5.0	.600
31	3/8	.53	13/32	1.25	5.0	.600

SPECIFICATION :-

THE MATERIAL TO BE TOOL STEEL TO AIR MINISTRY SPECIFICATION N^o71 TEMPER N^o5 (LATEST ISSUE)

ISSUED BY DRAWING OFFICE DIRECTORATE OF TECHNICAL DEVELOPMENT AIR MINISTRY	TITLE— TOOL RIVETING, SET-UP			RETRACED FOR <i>BR.G.</i>	DRAWN <i>W.Kempell</i>	TRACED <i>D.Randall</i> 24-6-21
	ISSUE No.	1 <i>A.G.S.</i>	2 <i>A.G.S.</i>	3 <i>A.G.S.</i>	CHECKED J.H. BRASHER	APPROVED <i>J.H.</i>

17.10.33
264854/33

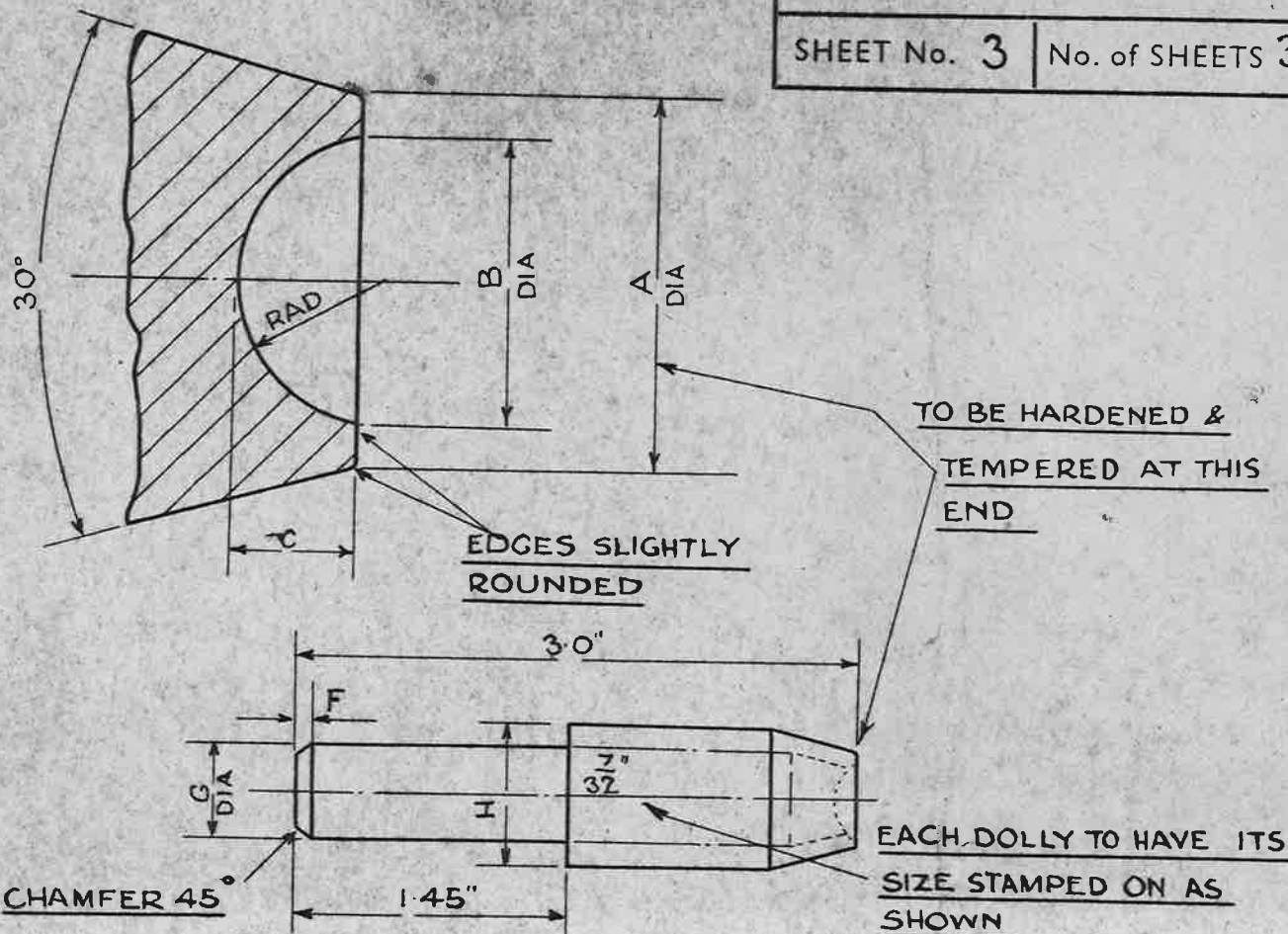

FOR PART Nos 41 TO 45 INCLUSIVE, DOLLY HAS STRAIGHT SHANK. FOR PART Nos ABOVE 45 DOLLY SHANK IS SHOULDERED

PART No	DIA OF RIVET	A	B	C ±.005	F	G		H
						HIGH	LOW	
41	1/16	.19"	.13"	.03"	.06"	.499"	.498"	
42	3/32	.24"	.17"	.04"	.06"	.499"	.498"	
43	1/8	.30"	.23"	.06"	.06"	.499"	.498"	
44	5/32	.35"	.28"	.07"	.06"	.499"	.498"	
45	3/16	.41"	.32"	.08"	.06"	.499"	.498"	
46	7/32	.46"	.38"	.10"	.09"	.499"	.498"	.75"
47	1/4	.52"	.43"	.11"	.09"	.499"	.498"	.75"
48	9/32	.58"	.49"	.12"	.09"	.499"	.498"	.75"
49	5/16	.63"	.54"	.14"	.09"	.499"	.498"	.75"
50	11/32	.69"	.58"	.15"	.09"	.499"	.498"	.75"
51	3/8	.75"	.64"	.17"	.12"	.499"	.498"	1.0"

SPECIFICATION: THE MATERIAL TO BE TOOL STEEL TO AIR MINISTRY SPECIFICATION No 71 TEMPER No 5 (LATEST ISSUE)

ISSUED BY DRAWING OFFICE DIRECTORATE OF TECHNICAL DEVELOPMENT AIR MINISTRY	TITLE— DOLLY FOR SOLID RIVETS					RETRACED FOR A.G.S. <i>BAE</i>	DRAWN G.H.ORMSTON	TRACED D.E.HALL 13-1-33
	ISSUE No.	1	2	3	4	5	CHECKED W.KEMPELL RE-CHECKED R.B.BASTABLE	APPROVED G.W.12-7-33
	ALTERATION	A.G.S. 232	A.G.S. 245	A.G.S. 247	A.G.S. 288	A.S. AGS/192		