

**OBSOLESCE**  
NO FURTHER  
MANUFACTURE

MINISTRY OF  
SUPPLY

AGS. No 888.

SHEET No. 1

No. OF SHEETS 1

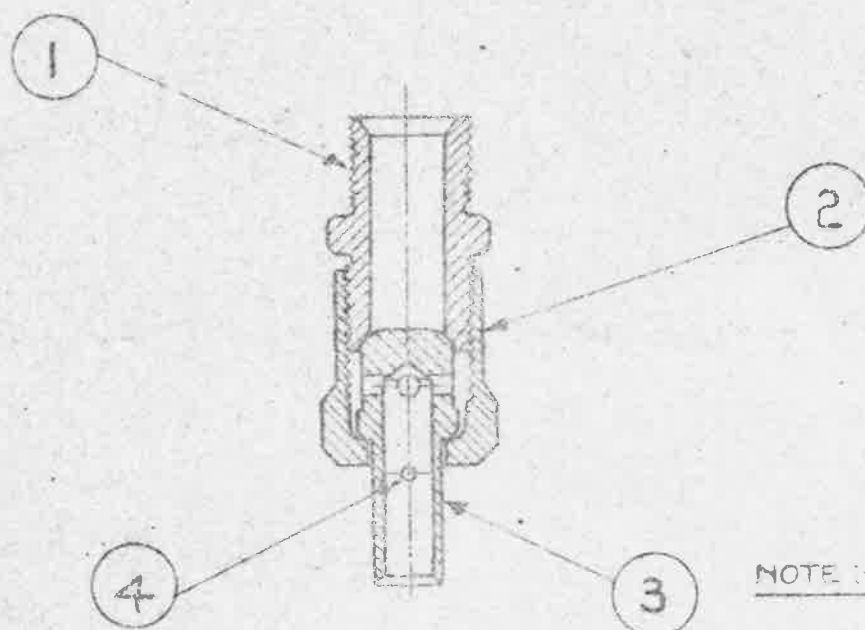

NOTE: - SEE S.I.S. 28, SHEET 4  
FOR METHOD OF  
LOCKING.

AGS. 888/3 TO BE  
LEGIBLY AND DURABLY  
MARKED IN POSITION SHOWN

FINISH: - TO BE CADMIUM PLATED TO SPEC:  
D.T.D. 904 (LATEST ISSUE),  
ALTERNATIVELY, ELECTRO-TIN  
TO SPEC. D.T.D. 924 (LATEST  
ISSUE)

25" SPHERICAL RADIUS

8 DIA HOLES AT  
RIGHT ANGLES.

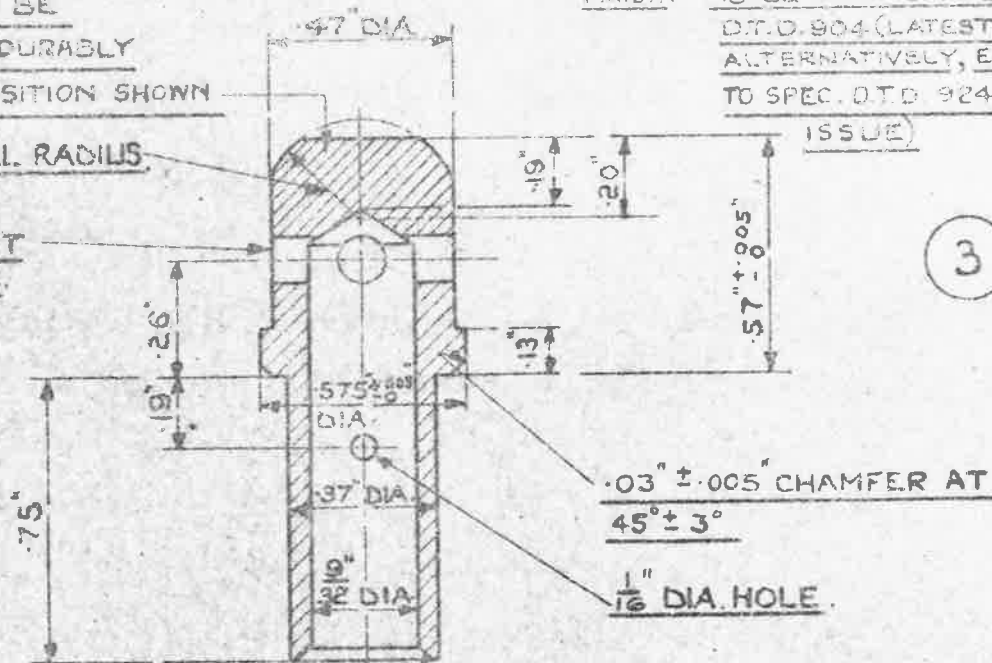

UNLIMITED DIMENSIONS  
TO BE WITHIN ± .01"

CHAMFER .04" ± .005"  
AT 45° ± 3°

BRASS BAR.  
B.S. SPEC. 251.  
LATEST ISSUE.

ONE COMPLETE COCK CONSISTS OF :-

PART NO	DRG. NO	DESCRIPTION	QUANTITY	REMARKS.
1	AGS. 627 - C	DOUBLE ENDED UNION BODY.	1	
2	AGS. 711 - C	METAL COUPLINGS-OUTER SLEEVE	1	
3	AGS. 888 - 3	NIPPLE.	1	
4	SP. 9/C. 6.	SPLIT PIN.	1	

REPRODUCED FROM MESSRS H.G. HAWKER ENGINEERING CO'S DRAWING NO A.26276.

ISSUED BY  
ROYAL  
AIRCRAFT  
ESTABLISHMENT

TITLE: - DRAIN COCK.

DRAWN  
ORMSTON

RE-TRACED  
30.12.38.

ISSUE No

1

2

3

4

5

CHECKED  
W.S. STARK 7/10/31

APPROVED  
G.W. 27-10-31.

ALTERATION No

250 AGS/98

AGS/663

811

900