

OBSOLESCE . NO FURTHER
 MANUFACTURE EXISTING STOCKS TO BE
 USED UP. REPLACED BY A.G.S. 900

AIR MINISTRY A.G.S. N° 891

SHT N° 1

N° OF SHTS :

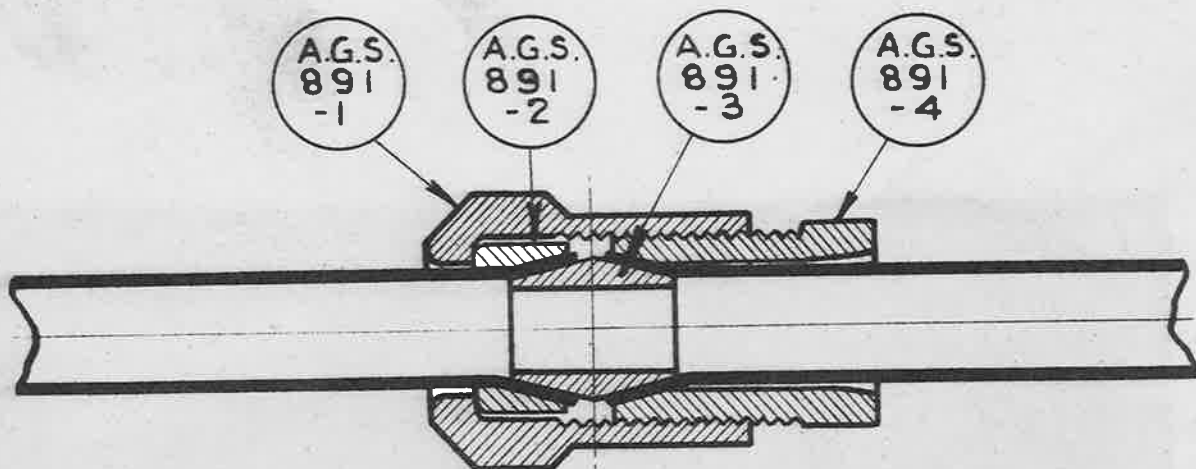

METAL PIPE COUPLING.

MARK

(A)

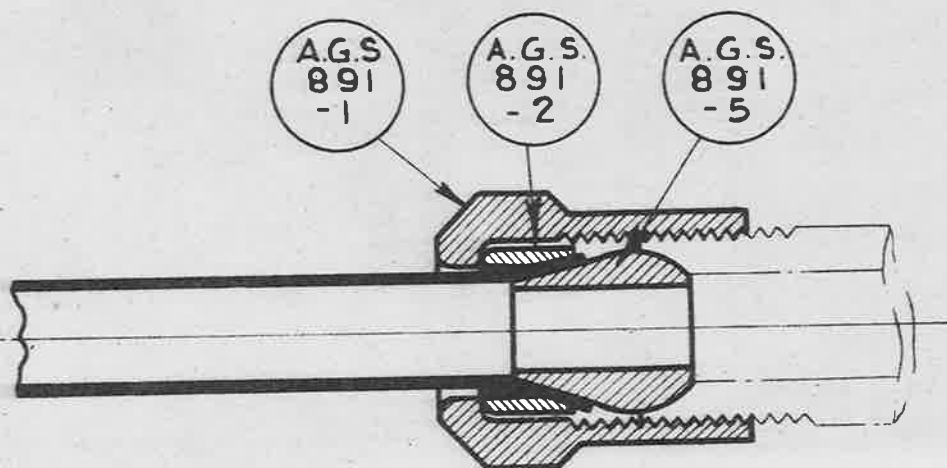

METAL PIPE JOINT

MARK

(B)

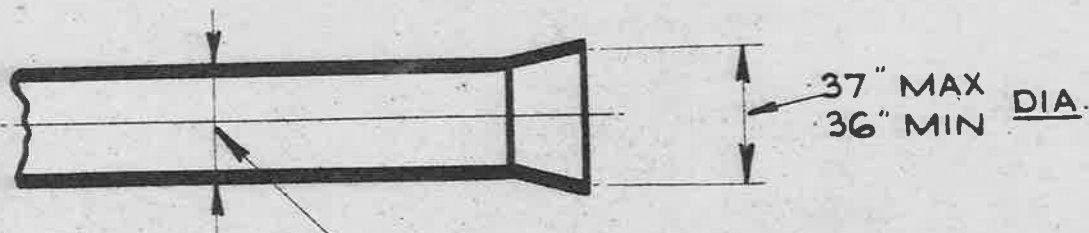

$\frac{5}{16}$ " ϕ D x 20 S.W.G. TUBE SPEC. T.7 (LATEST ISSUE)
 ONLY TO BE USED WITH THESE COUPLINGS.

ISSUED BY. D.O. DIRECTORATE OF TECHNICAL DEVELOPMT AIR MINISTRY.	TITLE :- METAL COUPLING (5/16 LIGHT TYPE)FOR AUTOMIC CONTROLS ONLY.				DRAWN. RH.VENNING	TRACE J. JOHN 21. 11. 31
	ISSUE N°	1	2	3	CHECKED	APPROV
	ALTER N°	A.G.S. 279/	MOD. AS457	MOD.NS AGS/352		

OBSOLESCENT. NO FURTHER MANUFACTURE. EXISTING STOCKS TO BE USED UP. REPLACED BY ACS900

AIR MINISTRY ACS N° 891

SHEET N° 2 N° OF SHEETS

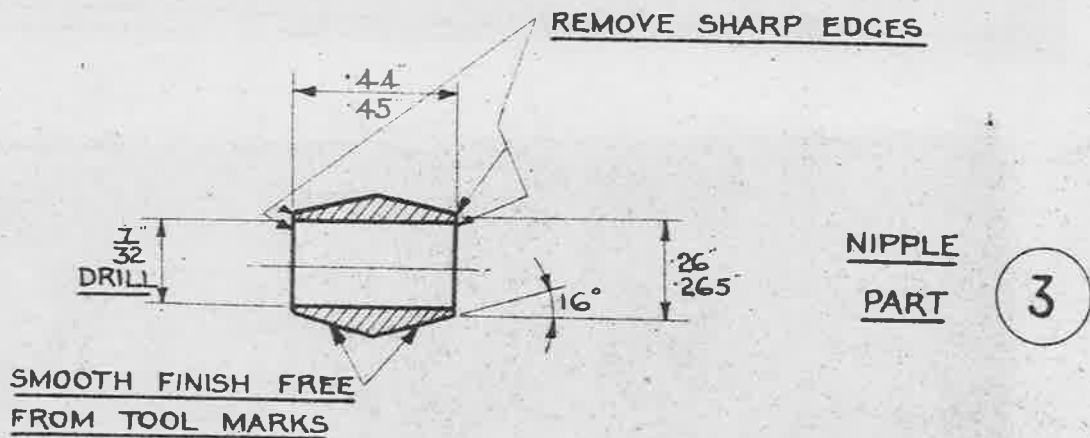
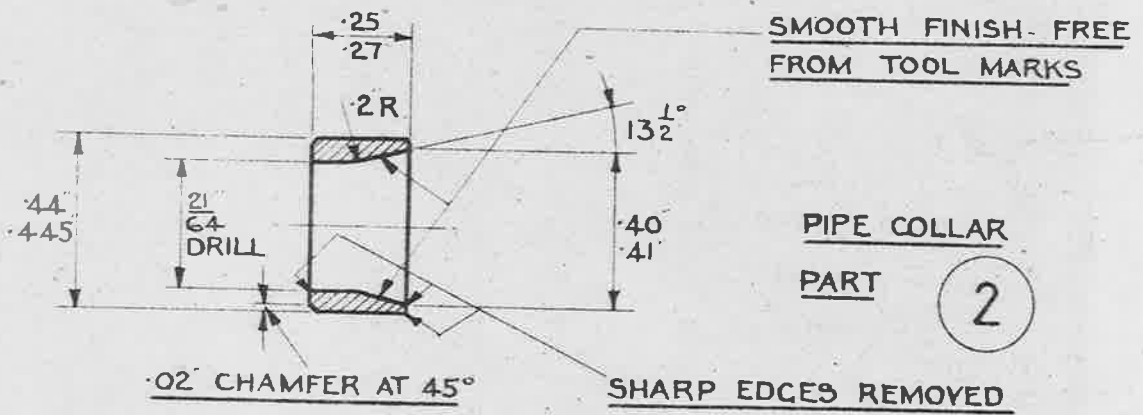
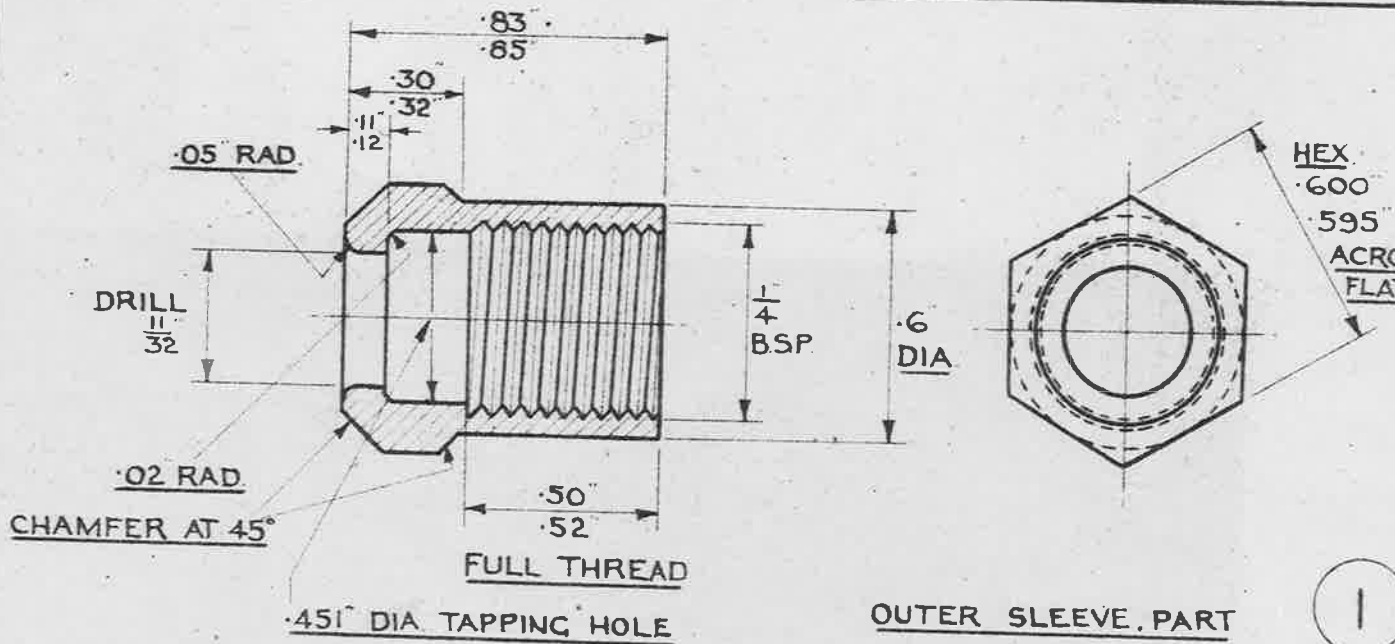

SPECIFICATION -

THE MATERIAL USED TO BE BRASS TO BRITISH STANDARD SPECIFICATION 251 (LATEST ISSUE) SCREW THREADS TO BE IN ACCORDANCE WITH B.S. SPEC: 84 - 1940 FOR B.S.P. MEDIUM FIT

ISSUE N° 6
ALTERN N° 7
MOD ACS/ACS/302
13.3.43 14.2.45

ISSUED BY DRAWING OFFICE DIRECTORATE OF TECHNICAL DEVELOPMENT AIR MINISTRY	TITLE = METAL COUPLING. DETAILS (5/16 LIGHT TYPE) FOR AUTOMATIC CONTROLS ONLY					DRAWN	TRACED L. COOK 12-11-45			
	ISSUE N°	1	2	3	4			5	CHECKED	APPROVED
	ALTER N°	ACS/279	ACS/128	ACS/200	ACS/212			ACS/273		

OBSOLESCENT. NO FURTHER MANUFACTURE. EXISTING STOCKS TO BE USED UP. REPLACED BY A.G.S. 900.

AIR MINISTRY. **AGS. N°891**

SHEET N°3. N° OF SHEETS 3.

SMOOTH FINISH FREE FROM TOOL MARKS.

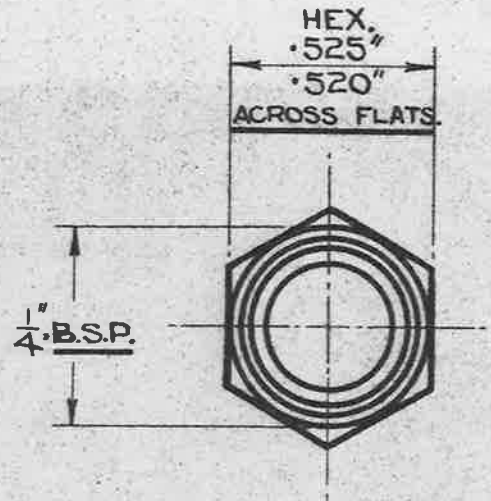
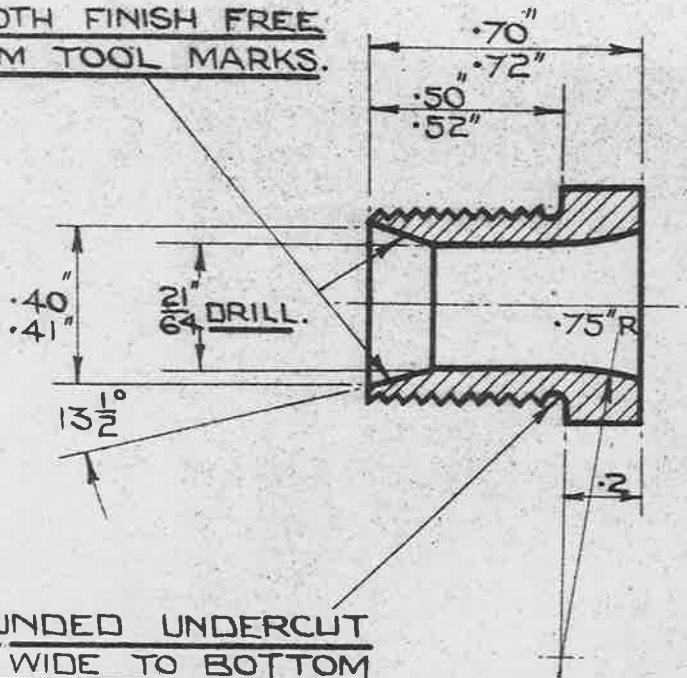

INNER SLEEVE PART.

④

ROUNDED UNDERCUT .06" WIDE TO BOTTOM OF THREAD.

SMOOTH FINISH FREE FROM TOOL MARKS.

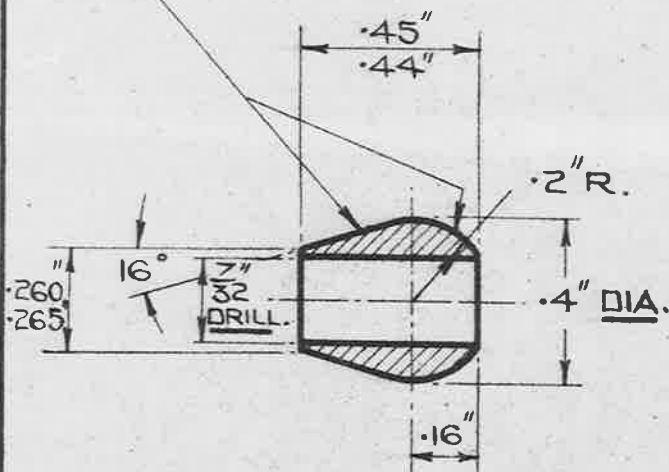

ADAPTOR NIPPLE PART.

⑤

SPECIFICATION:- THE MATERIAL USED TO BE BRASS TO BRITISH STANDARD SPECIFICATION.251 (LATEST ISSUE.)
SCREW THREADS TO BE IN ACCORDANCE WITH B.S. SPEC.; 84-1940 FOR B.S.P. MEDIUM FIT.

MOD. N° AGS/457
 A.S. N° 212
 AGS/212
 13-3-43 14-2-45

ISSUED BY DRAWING OFFICE DIRECTORATE OF TECHNICAL DEVELOPMENT AIR MINISTRY.

TITLE:- METAL COUPLING DETAILS (LIGHT TYPE) FOR AUTOMATIC CONTROLS ONLY.

ISSUE N°.	1	2	3	4	5
ALTER. N°.	AGS/279	AGS/	AGS/	AGS/212	AGS/

DRAWN. RE-TRACED. E.R. 14-11-45.

CHECKED. APPROVED.