

NOTE: - DIMENSION X - 27 MIN. 32 MAX.

AGS No. 900

SHEET No. 1 IN No. OF SHEETS 3

FOR P.C. D.
 DATE 12/12/47
 NO. 100/101/71

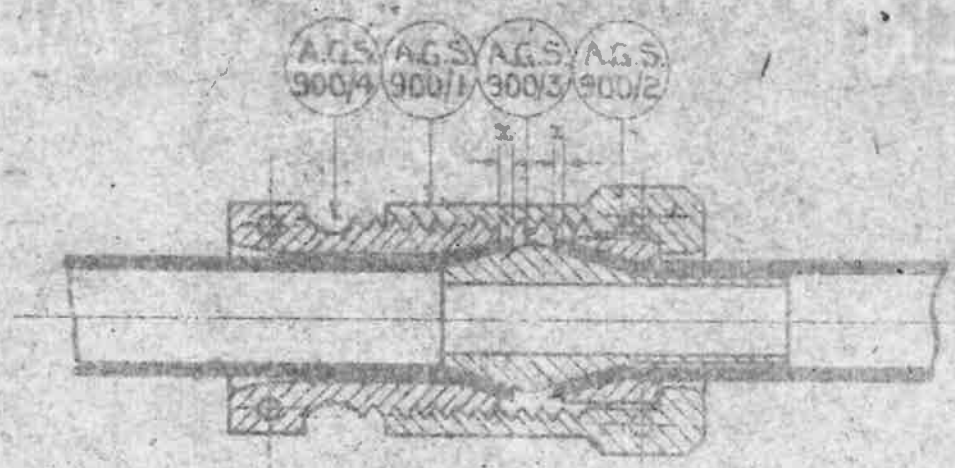

PIPE TO PIPE COUPLING MARK A.

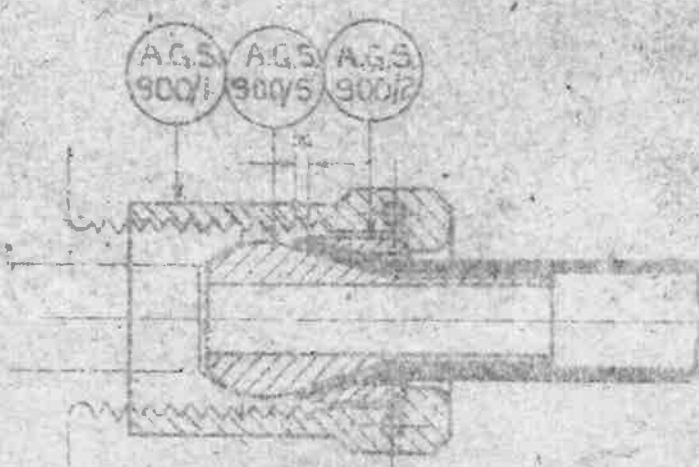

PIPE TO FITTING COUPLING MARK B.

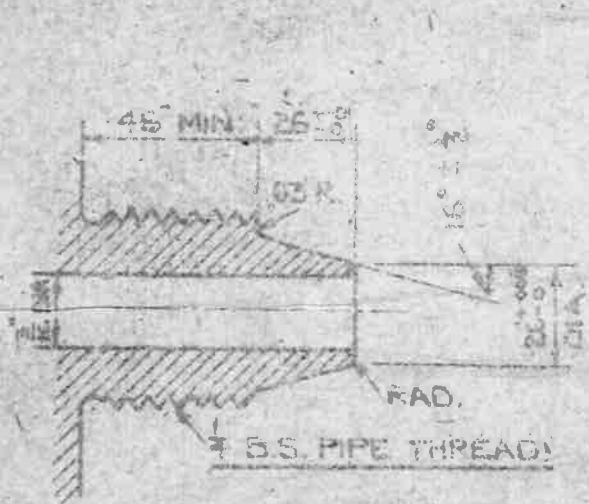

DIMENSIONS OF SPECIAL CONE END FOR LIGHT TYPE METAL COUPLINGS (25 DIA.)

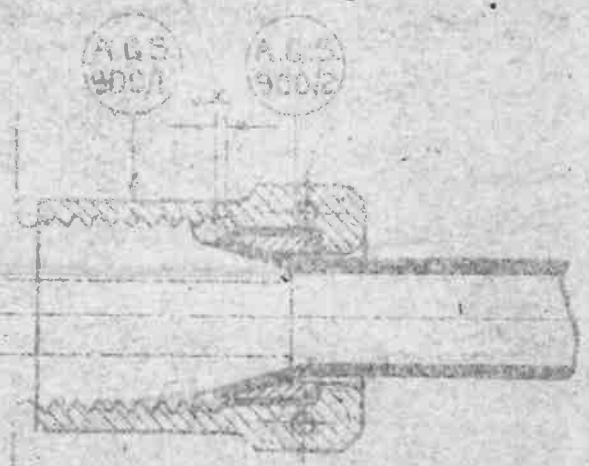

PIPE TO SPECIAL CONE END MARK C.

ISSUED BY THE
 ROYAL AIRCRAFT
 ESTABLISHMENT
 MINISTRY OF
 AIRCRAFT PRODUCTION

TITLE: - METAL COUPLINGS (LIGHT ALLOY)
 LIGHT TYPE FOR AUTOMATIC CONTROLS ONLY

ISSUE NO. 27 10-5
 ALTERS NO. 20 10-5

DRAWN: [Signature]
 CHECKED: [Signature]
 APPROVED: [Signature]
 R.F.L. 15-4-47

NOTE:- DIMENSION $x = \frac{1}{64}$ MIN. $\frac{3}{32}$ MAX:

MINISTRY OF SUPPLY

AGS. No 900.

SHEET No 1. No OF SHEETS 3.

SEE A.G.S. 100 FOR GENERAL INFORMATION.

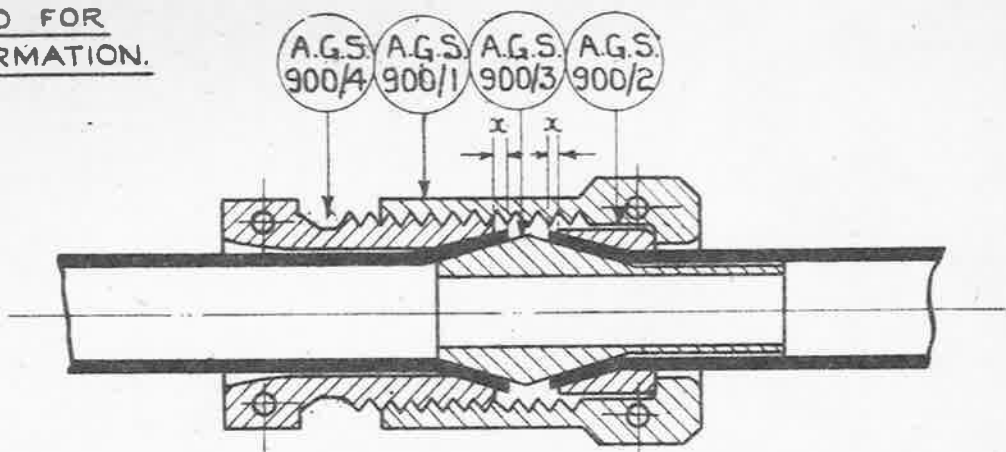

PIPE TO PIPE COUPLING. MARK A.

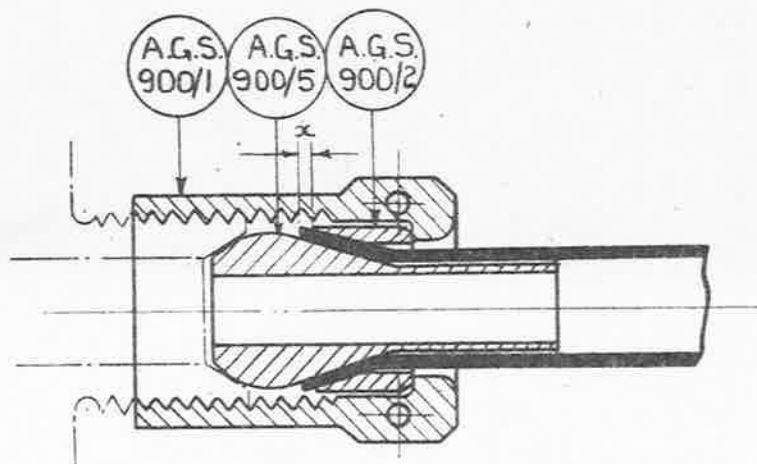

PIPE TO FITTING COUPLING. MARK B.

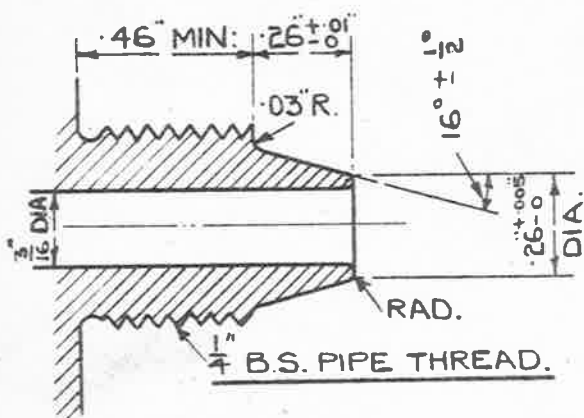

DIMENSIONS OF SPECIAL CONE END FOR LIGHT TYPE METAL COUPLINGS ($\frac{5}{16}$ DIA.)

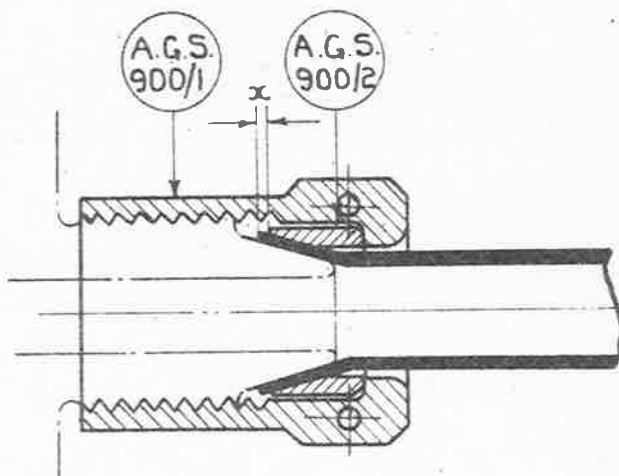

PIPE TO SPECIAL CONE END. MARK C.

ISSUED BY THE ROYAL AIRCRAFT ESTABLISHMENT.

TITLE:- METAL COUPLINGS. (LIGHT ALLOY) LIGHT TYPE FOR AUTOMATIC CONTROLS ONLY.

DRAWN *[Signature]*

TRACED R.F.C. 6-4-43.

ISSUE NO	20	A	8	6	6
ALTER NO	MOD. NO. A.G. 547	AS. NO. AGS/34	MOD. NO. AGS/609	AS. A.G.S. 988	SM856

CHECKED *[Signature]*

APPROVED *[Signature]* 9-4-43.

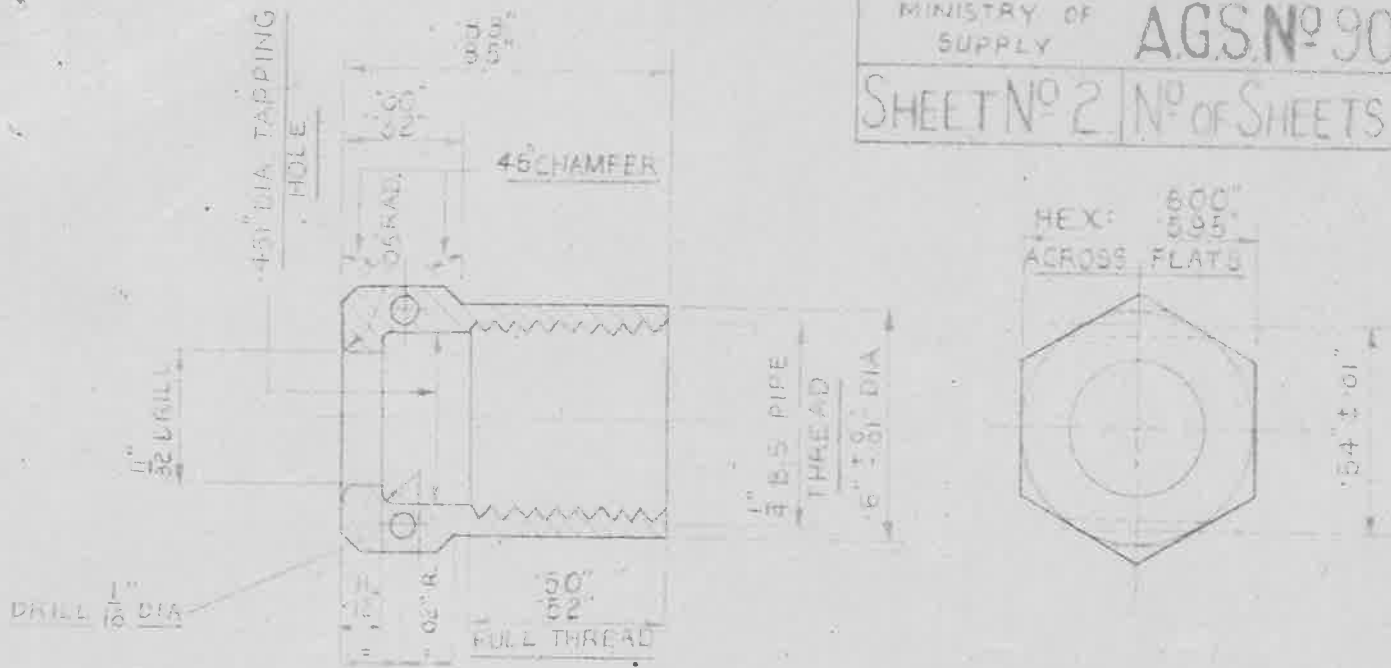

OUTER SLEEVE. PART ①

MATERIAL - LIGHT ALLOY. B.S. SPEC L1 (LATEST ISSUE) OR D.T.D. 423. (LATEST ISSUE)

FINISH - ANODISED TO SPEC. D.T.D. 910 (LATEST ISSUE)
SCREW THREAD TO B.S. SPEC. NR 84-1940 MEDIUM FIT.

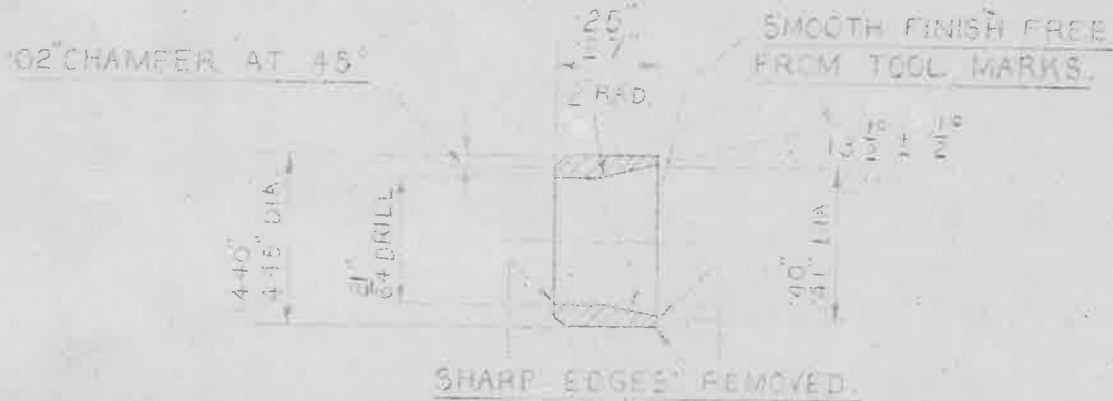

PIPE COLLAR. PART ②

MATERIAL - STEEL TO B.S. SPEC S1 OR 970 EN 6 OR B.S. SPEC. T1. OR B.S. SPEC. T1 (CONTAINING NOT MORE THAN 0.3% LEAD) (LATEST ISSUES)

FINISH - TO BE CADMIUM PLATED TO SPEC. D.T.D. 904 (LATEST ISSUE)

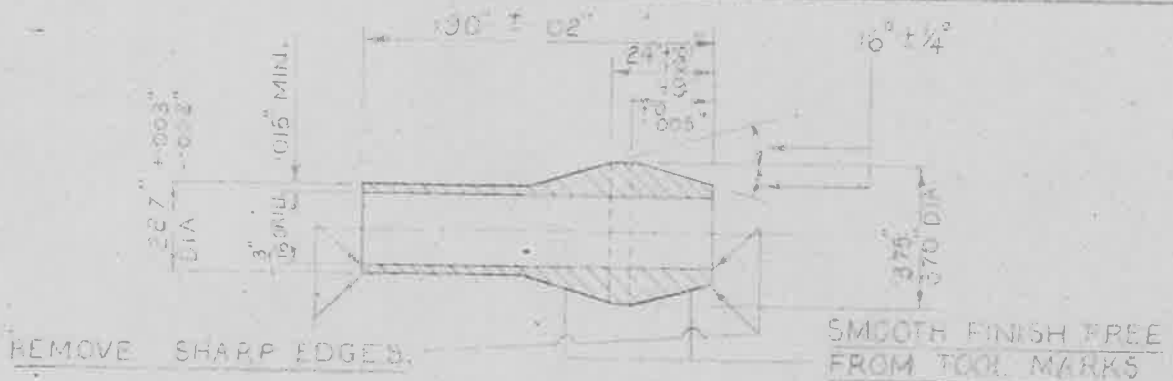

NIPPLE PART ③

MATERIAL - STEEL B.S. SPEC. S-1 OR 970 EN 6 (LATEST ISSUES)

FINISH - TO BE CADMIUM PLATED TO SPEC. D.T.D. 904 (LATEST ISSUE)

SEE A.G.S. 100
FOR GENERAL
INFORMATION.

MINISTRY OF
SUPPLY

AGS. No 900.

SHEET No 2. No OF SHEETS 3.

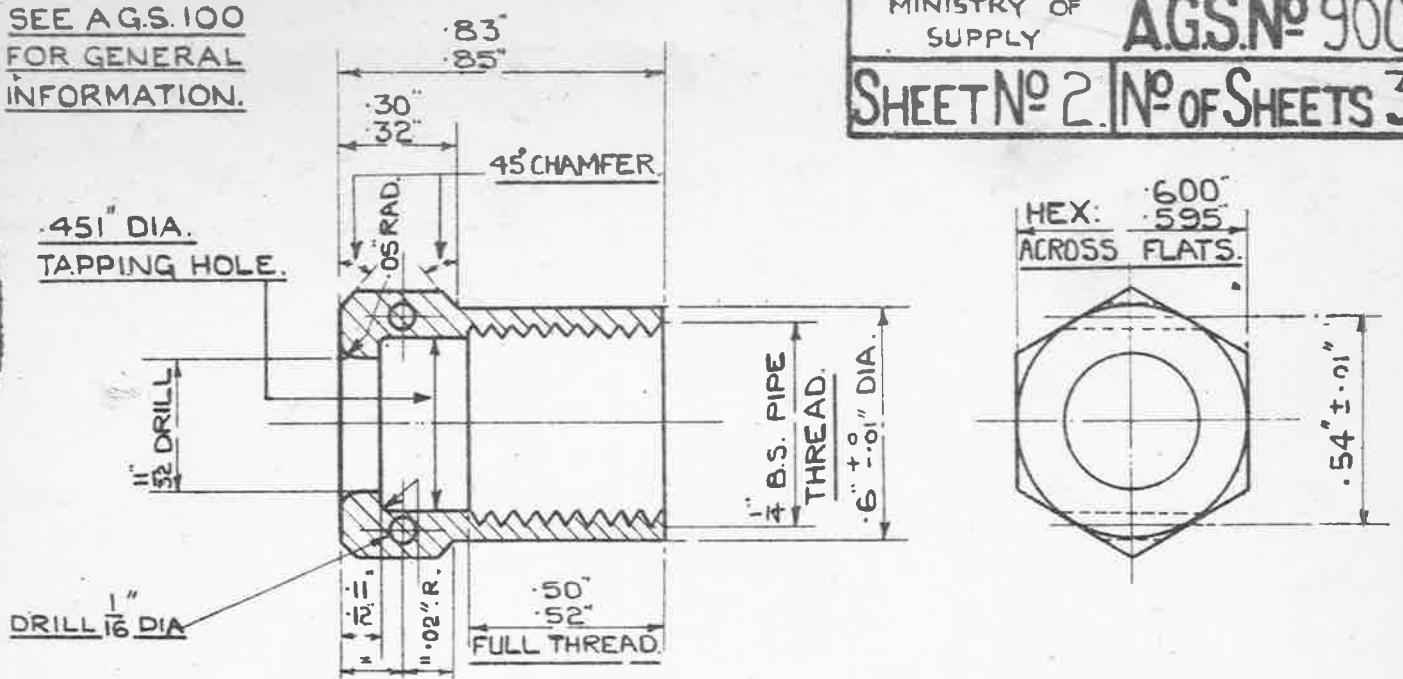

OUTER SLEEVE. PART ①

MATERIAL:- LIGHT ALLOY. B.S. SPEC. L.1. (LATEST ISSUE) OR D.T.D. 423.
(LATEST ISSUE)

FINISH:- ANODISED TO SPEC: D.T.D. 910 (LATEST ISSUE)
SCREW THREAD TO B.S. SPEC: No 84 - 1940,
MEDIUM FIT.

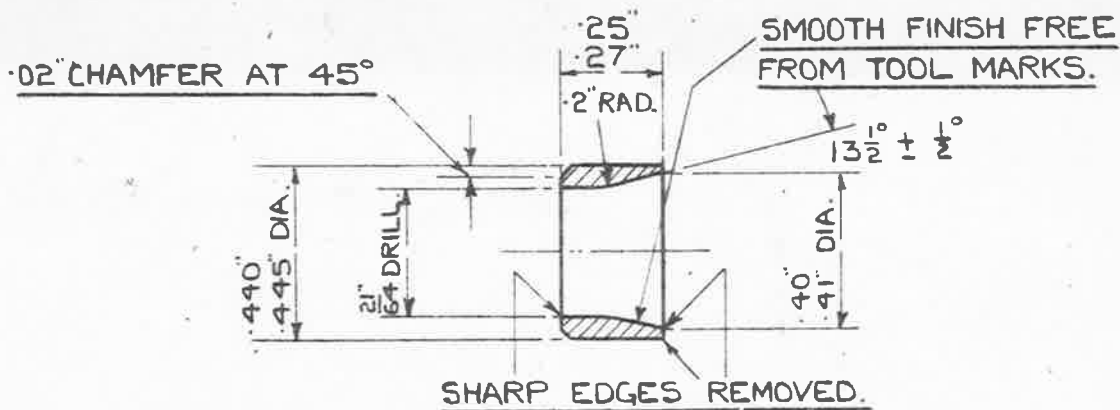

PIPE COLLAR. PART ②

MATERIAL:- STEEL TO B.S. SPEC. S.1. OR 970. EN. 6. OR B.S. SPEC. T.1.
OR B.S. SPEC. T.1. (CONTAINING NOT MORE THAN 0.3% LEAD.) (LATEST ISSUES)

FINISH:- TO BE CADMIUM PLATED TO SPEC. D.T.D. 904. (LATEST ISSUE).

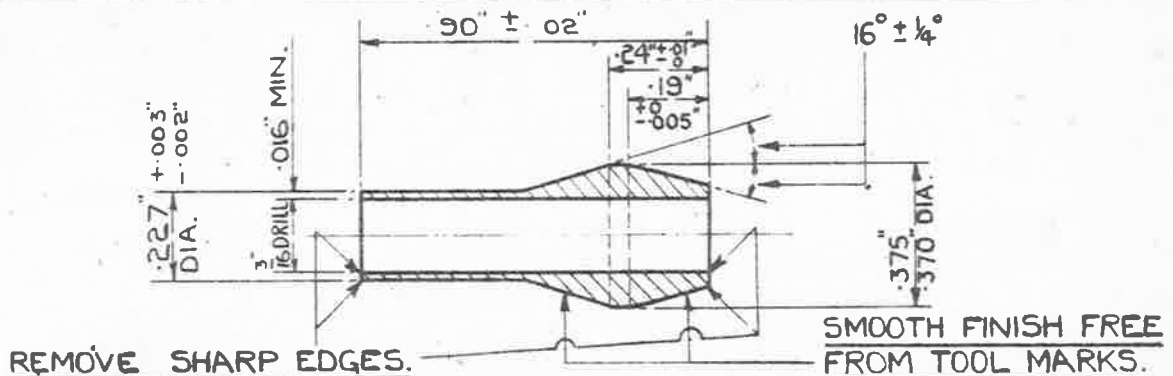

NIPPLE. PART ③

MATERIAL:- STEEL B.S. SPEC. S.-1. OR 970. EN. 6. (LATEST ISSUES)

FINISH:- TO BE CADMIUM PLATED TO SPEC. D.T.D. 904. (LATEST ISSUE)

ISSUED BY THE
ROYAL AIRCRAFT
ESTABLISHMENT.

TITLE:- METAL COUPLINGS. (LIGHT ALLOY)
LIGHT TYPE FOR AUTOMATIC CONTROLS ONLY.

DRAWN
J. 103.

TRACED
R.F.C.
6-4-43.

ISSUE No	13	14	14		
ALTERN No	A.S. No 13/42	AS/AG 13/42	SM856		

CHECKED
L. W. Jones

APPROVED.
9. 4. 43

SEE A.G.S. 100 FOR
GENERAL INFORMATION.

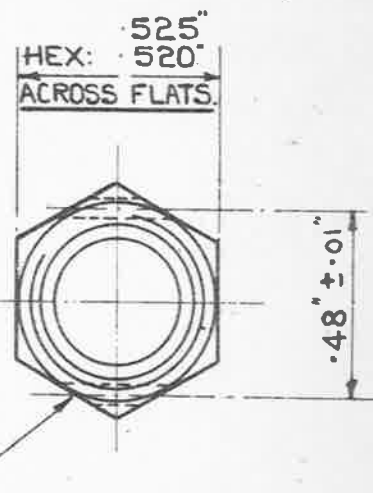
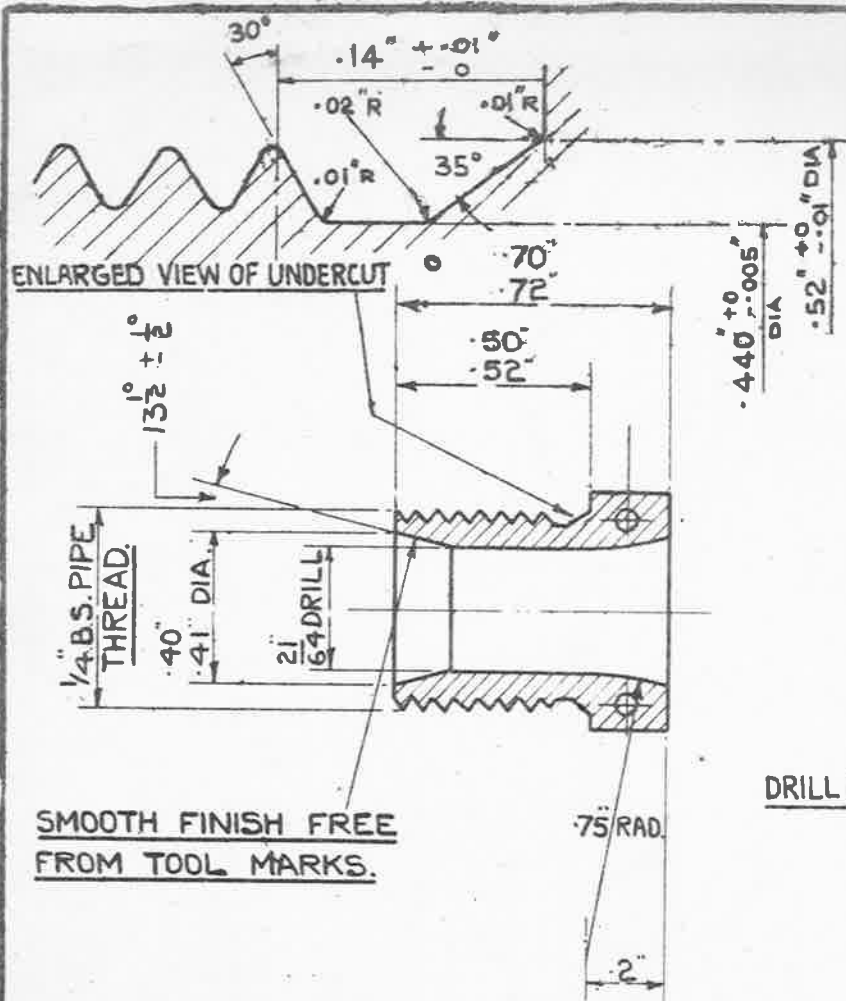

INNER SLEEVE - PART 4

MATERIAL:- LIGHT ALLOY B.S. SPEC. L.I. (LATEST ISSUE)
OR D.T.D. 423. (LATEST ISSUE)

FINISH:- ANODISED TO SPEC. D.T.D. 910 (LATEST ISSUE)
SCREW THREAD TO B.S. SPEC: No 84 - 1940,
MEDIUM FIT - TRUNCATED TO AMENDMENT No 3 - 1945.

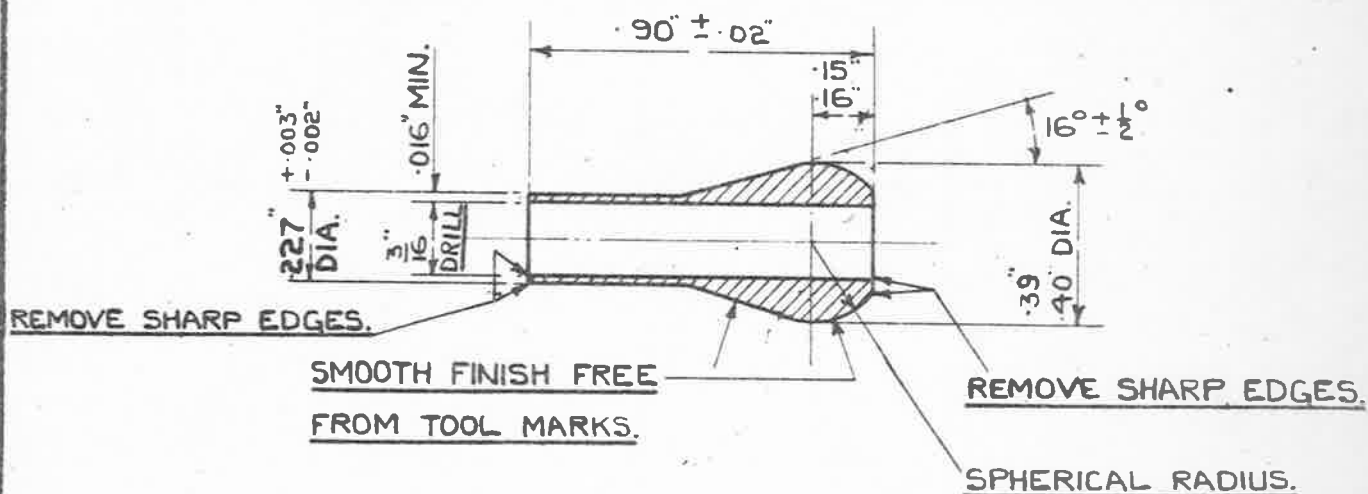

ADAPTOR NIPPLE - PART 5

MATERIAL:- STEEL B.S. SPEC. S.I. OR 970 En6 (LATEST ISSUES.)

FINISH:- TO BE CADMIUM PLATED TO SPEC: D.T.D. 904 (LATEST ISSUE).

ISSUED BY THE
ROYAL AIRCRAFT
ESTABLISHMENT.

TITLE:- METAL COUPLINGS (LIGHT ALLOY)
LIGHT TYPE FOR AUTOMATIC CONTROLS ONLY
SM 856

ISSUE NO	8	9	10	11	12
ALTERS NO					
MOD. NO	AGS/979	AGS/341	AGS/909	AGS/963	98R

DRAWN
R.A.B.

CHECKED
L. Washburn

TRACED
R.F.C.
5-4-43.

APPROVED.
J. H. H.

9.4.43