

SEE A.G.S. 100 FOR GENERAL INFORMATION.

BASED ON BLACKBURN-AIRCRAFT LTD DRG. No P 24

FOR MARKS J & K ONLY.

EIGHT HOLES  $\frac{13}{64}$ " DIA. EQUALLY SPACED AND EIGHT FLATS.

SIX HOLES  $\frac{13}{64}$ " DIA. EQUALLY SPACED.

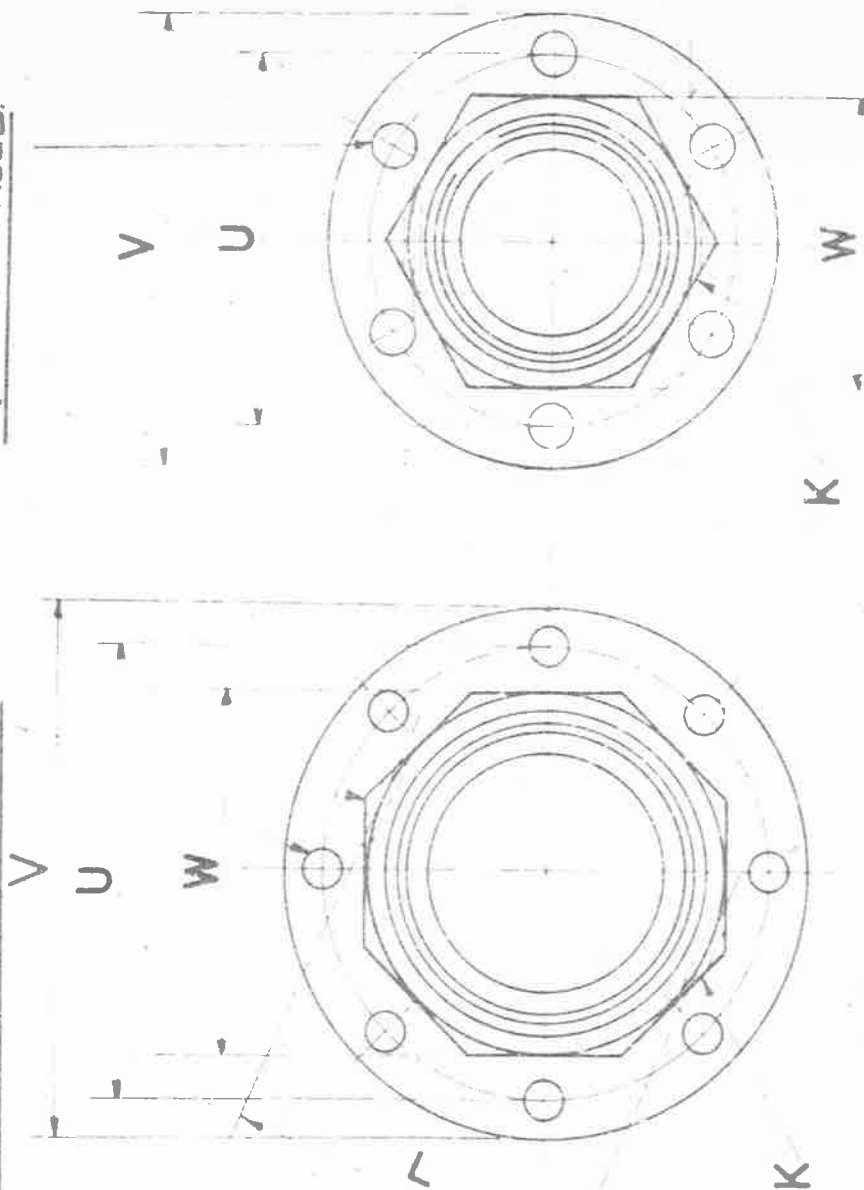
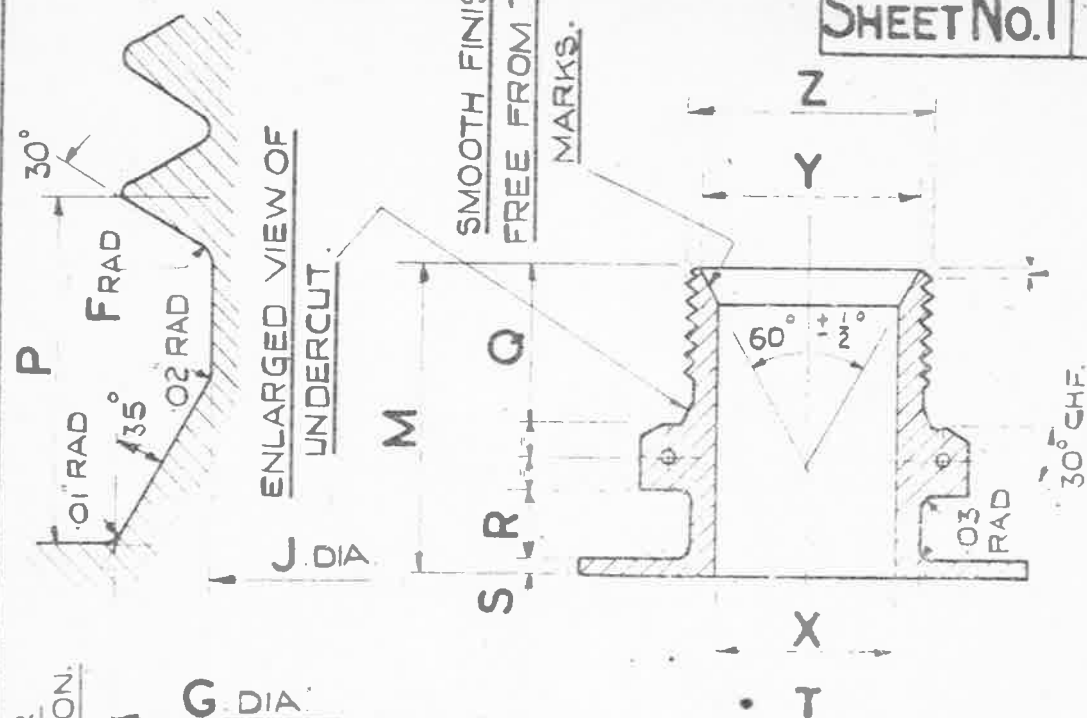

45° CHAMFER TO ROOT OF THREAD.

THE MATERIAL TO BE LIGHT ALLOY TO SPEC DTD 423. (LATEST ISSUE).

FINISH TO BE ANODISED TO SPEC DTD 90. (LATEST ISSUE).

NOTES:- SCREW THREADS TO BS SPEC N 84-1940, MEDIUM FIT, TRUNCATED THREADS TO AMENDMENT N°3-1945.

ISSUED BY THE ROYAL AIRCRAFT ESTABLISHMENT

TITLE:- MALE FLANGES (BOLTED); (LIGHT ALLOY).

DRAWN K. Wilson.

TRACED EASTON 20-10-45

ISSUE No	3	4	5	5
ALTER. No	MOD No AGS 609	AS No AGS 603	AS/ACS 988	SM 856

CHECKED

APPROVED

C. T. Reynolds

*[Signature]*

BASED ON BLACKBURN-AIRCRAFT LTD DRG NO P 24

FOR MARKS J & K ONLY.  
EIGHT HOLES  $1\frac{3}{64}$ " DIA EQUALLY SPACED AND EIGHT FLATS.

SIX HOLES  $1\frac{3}{64}$ " DIA EQUALLY SPACED.

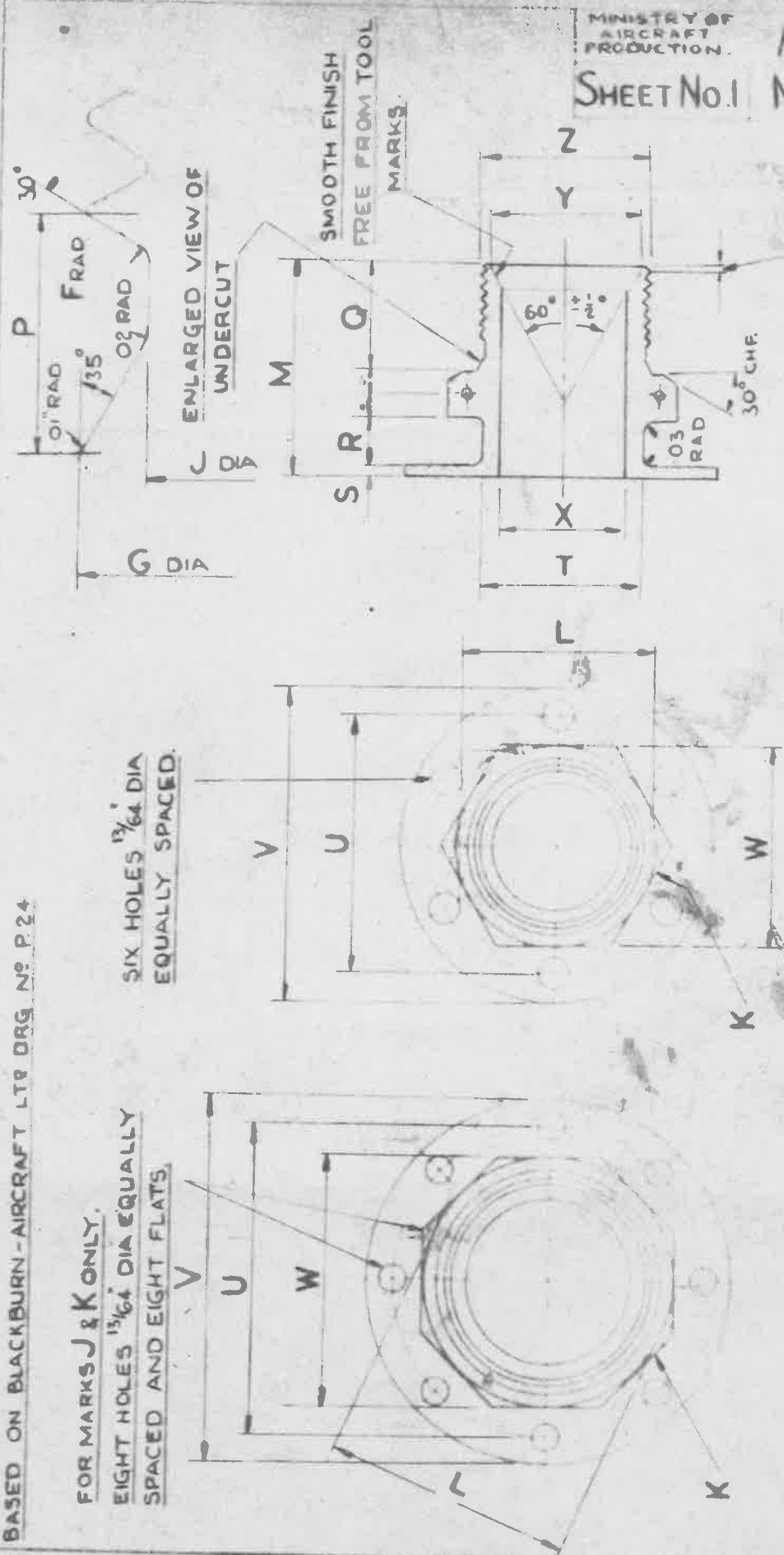

THE MATERIAL TO BE LIGHT ALLOY TO SPEC DTD 423, (LATEST ISSUE)  
FINISH:- TO BE ANOISED TO SPEC. DTD. 910, (LATEST ISSUE)  
NOTES:- SCREW THREADS TO BS SPEC NO 84-1940  
MEDIUM FIT, TRUNCATED THREADS TO AMENDMENT NO.3-1945

ISSUED BY THE ROYAL AIRCRAFT ESTABLISHMENT	TITLE:- MALE FLANGES (BOLTED) (LIGHT ALLOY)		DRAWN	TRACED
	ISSUE NO	3	4	CHECKED
	ALTER. NO		AS NO AGS/063	APPROVED

Handwritten signature or initials at the bottom left of the page.

28.1.46  
REV. AGS. 148

BASED ON BLACKBURN AIRCRAFT LTD. DRG. NE P24

MINISTRY OF  
AIRCRAFT  
PRODUCTION

AGS. No. 977

SHEET No. 2 No. OF SHEETS

MARK	Z	Y	X	W		V	U	T	S	R	Q	P	M	L	K	J	G	F
	B.S.P. THREAD	±.005"	DIA DRILL	MIN	MAX	±.005"	±.005"	±.01" ±.0	±.005" ±.01" ±.0	±.005" ±.01" ±.0	±.01" ±.0	±.01" ±.0	±.01" ±.01"	±.01"	DIA DRILL	+0 -0.005"	+0 -0.01"	RAD.
A	1/8"	.295"	3/16"	.520"	.525"	1.42"	1.025"	.370"	.08"	.35"	.45"	.10"	1.03"	.48"	1/16"	.330"	.39"	.01"
B	1/4"	.41"	1/4"	.705"	.710"	1.50"	1.10"	.437"	.08"	.35"	.45"	.14"	1.06"	.67"	1/16"	.440"	.52"	.01"
BB	.60% 19 T.P.I.	.48"	5/16"	.760"	.765"	1.60"	1.20"	.500"	.08"	.35"	.52"	.14"	1.15"	.73"	1/16"	.525"	.60"	.01"
C	3/8"	.55"	3/8"	.815"	.820"	1.70"	1.30"	.562"	.08"	.35"	.55"	.14"	1.20"	.79"	1/16"	.580"	.66"	.01"
CC	.75% 14 T.P.I.	.60"	7/16"	.915"	.920"	1.80"	1.40"	.625"	.08"	.35"	.55"	.18"	1.22"	.92"	1/16"	.650"	.75"	.015"
D	1/2"	.69"	1/2"	1.002"	1.010"	1.90"	1.50"	.687"	.08"	.35"	.60"	.18"	1.28"	.96"	1/16"	.720"	.83"	.015"
E	5/8"	.76"	9/16"	1.092"	1.100"	2.00"	1.60"	.812"	.08"	.35"	.70"	.18"	1.41"	1.06"	1/16"	.800"	.91"	.015"
F	3/4"	.90"	1 1/16"	1.192"	1.200"	2.10"	1.70"	.937"	.08"	.35"	.75"	.18"	1.49"	1.17"	1/16"	.940"	1.05"	.015"
G	7/8"	1.04"	1 1/8"	1.382"	1.390"	2.25"	1.85"	1.062"	.08"	.35"	.80"	.18"	1.56"	1.37"	.076" (N° 48)	1.085"	1.19"	.015"
H	1"	1.13"	1 1/8"	1.468"	1.480"	2.35"	1.95"	1.187"	.08"	.35"	.80"	.23"	1.58"	1.47"	.076" (N° 48)	1.18"	1.31"	.02"
J	1 1/4"	1.45"	1 7/32"	1.845"	1.860"	2.75"	2.35"	1.468"	.08"	.35"	.80"	.23"	1.61"	1.85"	.076" (N° 48)	1.52"	1.66"	.02"
K	1 1/2"	1.68"	1 15/32"	2.200"	2.220"	3.15"	2.70"	1.625"	.08"	.35"	.85"	.23"	1.68"	2.14"	.076" (N° 48)	1.75"	1.89"	.02"

ISSUED BY THE  
ROYAL  
AIRCRAFT  
ESTABLISHMENT

TITLE: MALE FLANGES, (BOLTED),  
(LIGHT ALLOY)

ISSUE No. 1

ALTER. No. 460 No. 465/609  
28.1.46  
C.T.R.

DRAWN  
K. Wilson

CHECKED  
C.T. Reynolds

TRACED  
1 FEB  
20 10-45

APPROVED