

45° CHAMFER TO  
ROOT OF THREAD.

BASED ON BLACKBURN-AIRCRAFT LTD DRAWING No P.24.

**OBSOLESCENT.** NO FURTHER MANUFACTURE.

FOR MARKS J & K ONLY,

<sup>13</sup>/<sub>16</sub>"  
EIGHT HOLES 64 DIA. EQUALLY  
SPACED AND EIGHT FLATS.

<sup>13</sup>/<sub>16</sub>"  
SIX HOLES 64 DIA.  
EQUALLY SPACED.

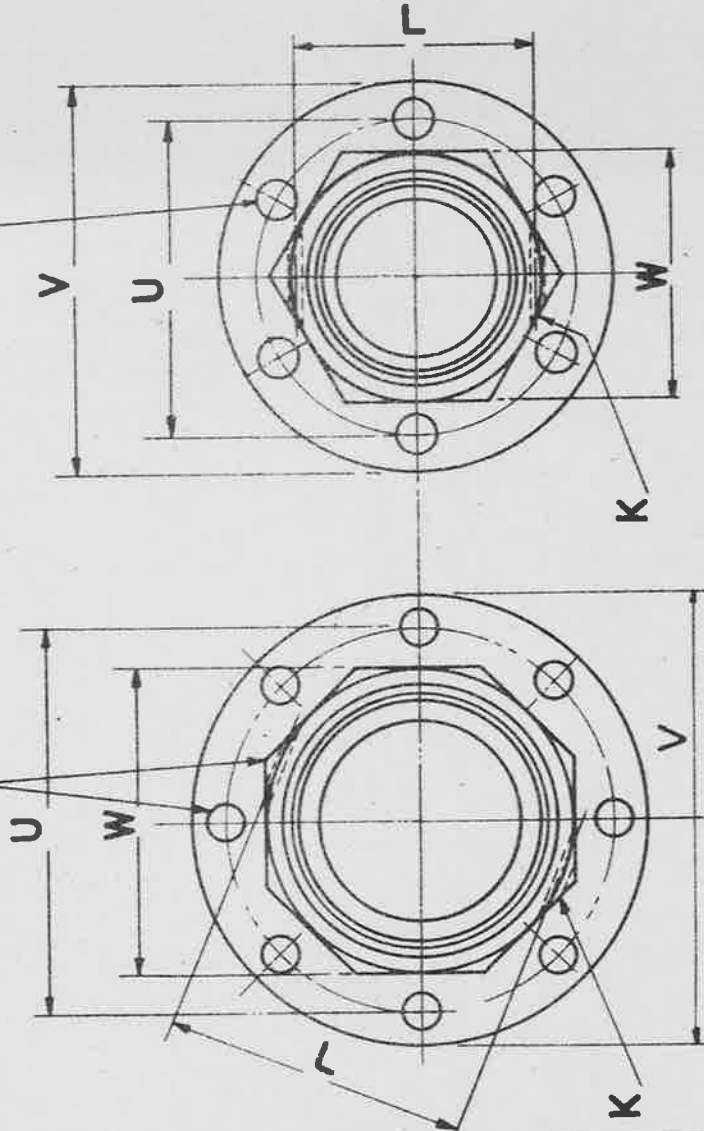

THE MATERIAL TO BE BRASS TO B.S. SPEC. No. 249 OR 251, (LATEST ISSUES).  
FINISH: TO BE CADMIUM PLATED TO SPEC. D.T.D. 904 (LATEST ISSUE),  
ALTERNATIVELY, ELECTRO-TINNED, THICKNESS NOT LESS THAN .0002".  
NOTE:- SCREW THREADS TO B.S. SPEC. No. 84. -1940,  
MEDIUM FIT, TRUNCATED THREADS, TO AMENDMENT No 3 - 1945.

ISSUED BY ROYAL AIRCRAFT ESTABLISHMENT.	TITLE:- MALE FLANGES. (BOLTED). (BRASS).				DRAWN K. Wilson.	TRACED J. Johnson. 23-10-45.
	ISSUE No 3.	REV. No 1.	REV. No 4.	REV. No 5.	CHECKED C.T. Reynolds	APPROVED Jona 2/1/45
	MOD No AGS/609	A.S. No AGS/663	REV/AGS 883			

28.1.46  
REV. AGS. 145

BASED ON BLACKBURN AIRCRAFT LTP DRG. NO P 24

MINISTRY OF  
SUPPLY

AC5 No 979

**OBSOLESCENT.**  
NO FURTHER MANUFACTURE.

SHEET No. 2 NO OF SHEETS 2

MARK	Z	Y	X	W		V	U	T	S	R	Q	P	M	L	K	J	G	F
	B.S.P. THREAD	±.005"	DIA. DRILL.	MIN	MAX.	±.005"	±.005"	+ .01" - 0	+ .01" - 0	±.005"	±.01"	+ .01" - 0	±.01"	±.01"	DIA DRILL	+ 0 - .005"	+ 0 - .01"	RAD
A	1" / 8	.295"	3" / 16	.520"	.525"	1.42"	1.025"	.08"	.08"	.35"	.45"	.10"	1.03"	.48"	1/16	.330"	.39"	.01"
B	1" / 4	.41"	1/4	.705"	.710"	1.50"	1.10"	.08"	.08"	.35"	.45"	.14"	1.06"	.67"	1/8	.440"	.52"	.01"
BB	60% / 19 TPI	.46"	5" / 16	.760"	.765"	1.60"	1.20"	.08"	.08"	.35"	.52"	.14"	1.15"	.73"	1/8	.525"	.60"	.01"
C	3" / 8	.55"	3" / 8	.815"	.820"	1.70"	1.30"	.08"	.08"	.35"	.55"	.14"	1.20"	.79"	1/16	.580"	.66"	.01"
CC	75% / 14 TPI	.60"	7" / 16	.915"	.920"	1.80"	1.40"	.08"	.08"	.35"	.55"	.16"	1.22"	.92"	1/8	.650"	.75"	.015"
D	1"	.69"	1"	1.002"	1.010"	1.90"	1.50"	.08"	.08"	.35"	.60"	.18"	1.28"	.96"	1/16	.720"	.83"	.015"
E	5" / 8	.76"	9" / 16	1.092"	1.100"	2.00"	1.60"	.08"	.08"	.35"	.70"	.18"	1.41"	1.08"	1/8	.800"	.91"	.015"
F	3" / 4	.90"	1 1/8	1.192"	1.200"	2.10"	1.70"	.08"	.08"	.35"	.75"	.18"	1.49"	1.17"	1/8	.940"	1.05"	.015"
G	7" / 8	1.04"	1 1/8	1.362"	1.390"	2.25"	1.85"	.08"	.08"	.35"	.80"	.18"	1.56"	1.37"	.076" (N#48)	1.085"	1.19"	.015"
H	1"	1.13"	1 1/2	1.468"	1.480"	2.35"	1.95"	.08"	.08"	.35"	.80"	.23"	1.58"	1.47"	.076" (N#48)	1.16"	1.31"	.02"
J	1 1/2	1.45"	1 3/4	1.845"	1.860"	2.75"	2.35"	.08"	.08"	.35"	.80"	.23"	1.61"	1.85"	.076" (N#48)	1.52"	1.66"	.02"
K	1 1/2	1.68"	1 5/8	2.200"	2.220"	3.15"	2.70"	.08"	.08"	.35"	.65"	.23"	1.68"	2.14"	.076" (N#48)	1.75"	1.89"	.02"

ISSUED BY THE  
ROYAL  
AIRCRAFT  
ESTABLISHMENT.

TITLE:- MALE FLANGES.  
(BOLTED), (BRASS).

ISSUE NO X 2  
ALTER<sup>N</sup> NO Mod No AGS/609 Mod/AGS 883

DRAWN K. Wilson  
CHECKED C.T. Reynolds  
TRACED m. Whaley 23-10-45  
APPROVED JMA 2/11/45

28.2.46 SM 538  
CTR