

THE MATERIAL TO BE STEEL TO B.S SPEC: S.I. (LATEST ISSUE).
 FINISH: TO BE CADMIUM PLATED TO SPEC: D.T.D. 904 (LATEST ISSUE)
 NOTE: SCREW THREADS TO B.S. SPEC: N° 84 - 1940,
 MEDIUM FIT, TRUNCATED THREADS TO AMENDMENT N° 3 - 1945.

SEE A.G.S. 100 FOR
GENERAL INFORMATION.

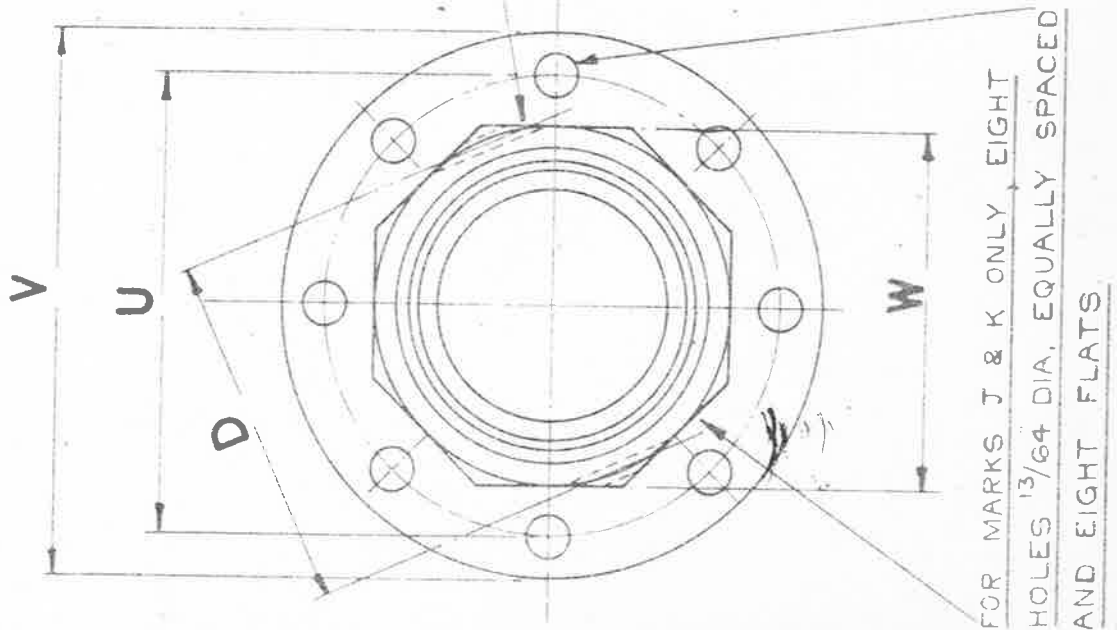

FOR MARKS J & K ONLY, EIGHT
HOLES $\frac{13}{64}$ DIA, EQUALLY SPACED
AND EIGHT FLATS

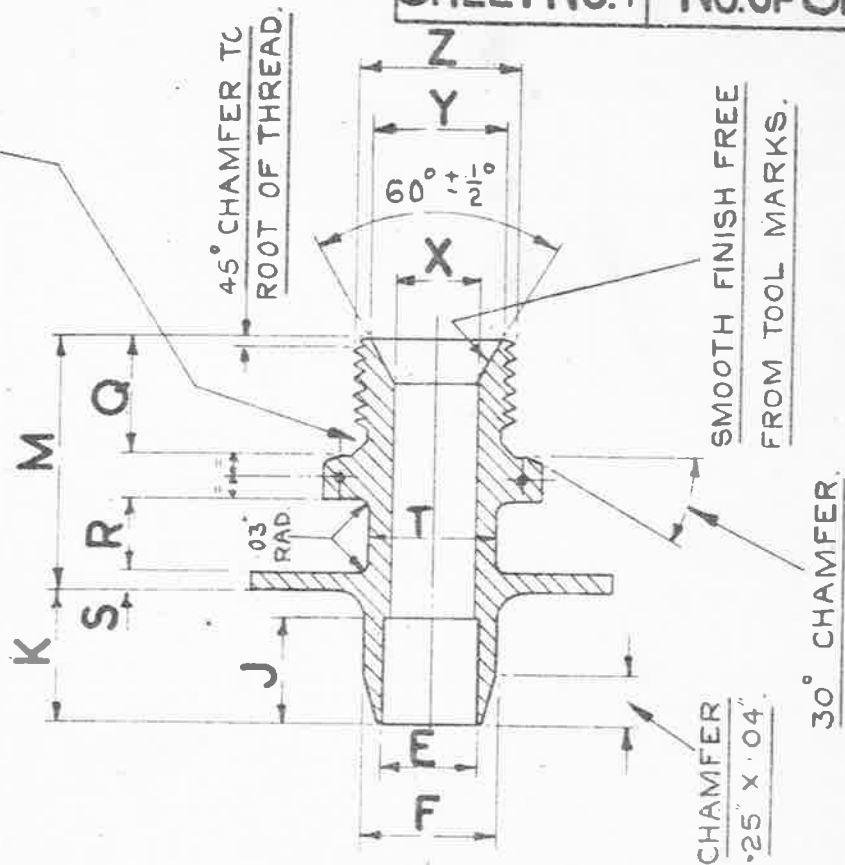

SMOOTH FINISH FREE
FROM TOOL MARKS.

30° CHAMFER

CHAMFER
.25" X .04"

ISSUED BY ROYAL AIRCRAFT ESTABLISHMENT	TITLE:- MALE FLANGES, (BOLTED), WITH SPIGOT. - STEEL.				DRAWN C.T. Reynolds	TRACED I.M. BROWN 19-10-45
	ISSUE N°	3	4	5		
ALTER N°	MOD N°	A.S. N°	AS/ACS	SM	CHECKED	APPROVED
	AGS/609	AGS/603	988	856	<i>[Signature]</i>	<i>[Signature]</i> 5/11/45

D. P. L. DATE 29.1.45 SIGRES. AGS. 145

THE MATERIAL TO BE STEEL TO B.S. SPEC. S. 1. (LATEST ISSUE)

FINISH: TO BE ZINC OR CADMIUM PLATED TO SPEC. D.T.D. 903, OR 904, (LATEST ISSUES)

NOTE: SCREW THREADS TO B.S. SPEC. N° 64 - 1940, MEDIUM FIT, TRUNCATED THREADS TO TABLE 27.

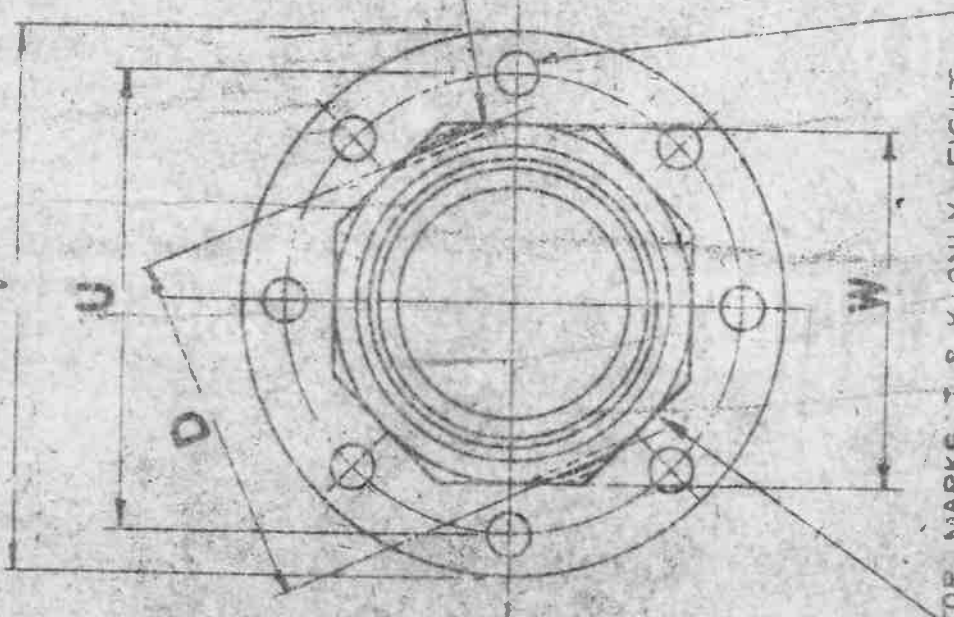
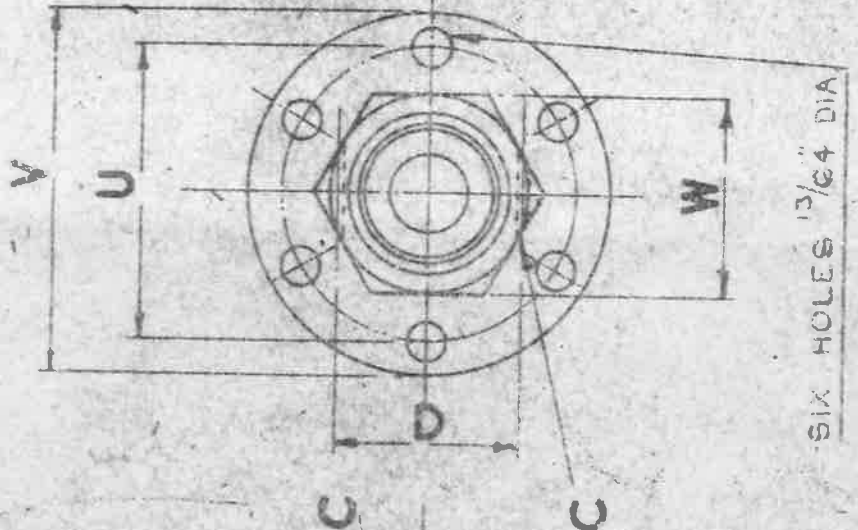
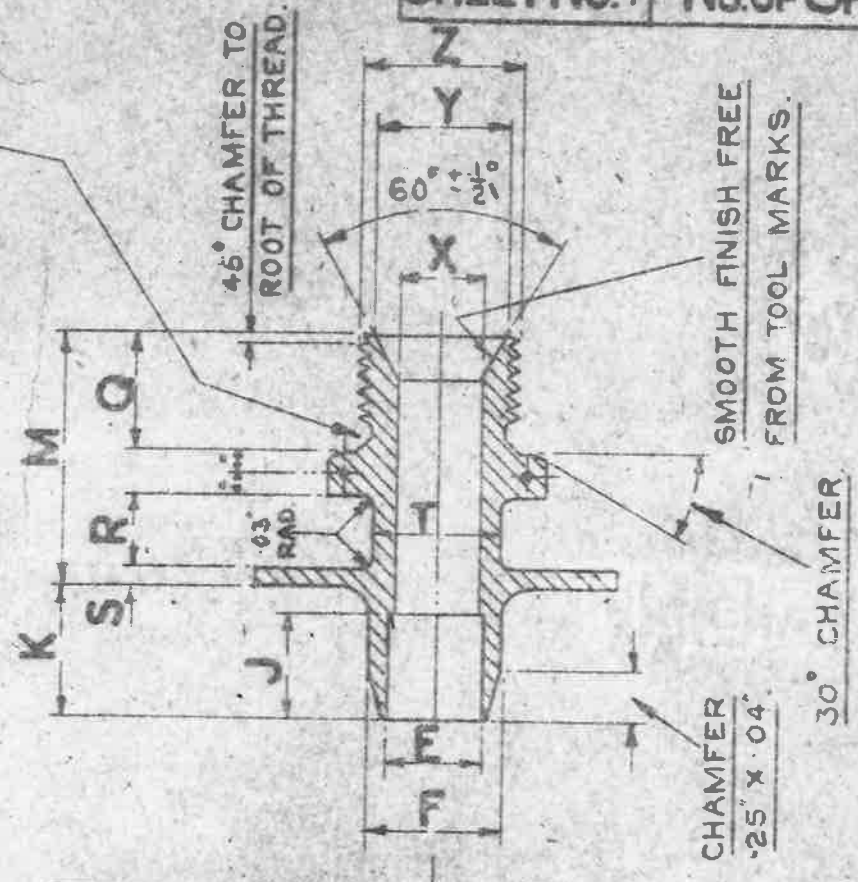
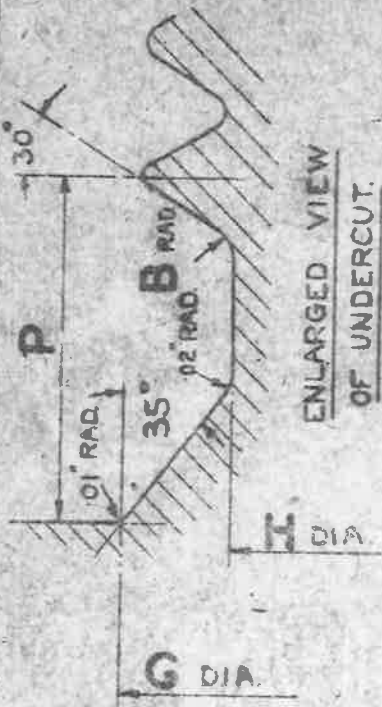

ISSUED BY ROYAL AIRCRAFT ESTABLISHMENT	TITLE - MALE FLANGES, (BOLTED), WITH SPIGOT. - STEEL.		DRAWN C.T. Reynolds	TRACED I.M. Brown 19-10-45
	ISSUE NO	3		
	ALTERS NO	100 N° 101/502		

MARK	Z BSP THREAD	Y ±.005	X DIA DRILL	W		V	U	T	S	R	Q	P	M	K	J	H	G	F	E	D	C	B
				MIN	MAX																	
A	1/4	295	1/8	520	525	142	1025	370	08	35	45	10	103	50	40	330	39	34	187	.48	1/16	.01
B	1/4	410	3/16	705	710	150	1100	437	08	35	45	14	106	50	40	440	52	40	250	67	1/16	.01
BB	19TPI 60%	480	1/4	760	765	160	1200	500	08	35	52	14	115	50	40	525	60	47	312	73	1/16	.01
C	1/8	550	5/16	815	820	170	1300	562	08	35	55	14	120	52	42	580	68	53	375	79	1/16	.01
CC	14TPI 75%	600	3/8	915	920	180	1400	625	08	35	55	18	122	58	46	650	75	59	437	92	1/16	.015
D	1/2	690	1/2	1002	1010	190	1500	687	08	35	60	18	128	65	53	720	83	66	500	96	1/16	.05
E	5/8	750	5/8	1092	1100	200	1600	812	08	35	70	18	141	79	67	800	91	72	625	106	1/16	.05
F	3/4	900	1/2	1192	1200	210	1700	937	08	35	75	18	149	96	80	940	105	90	750	117	1/16	.05
G	1	1040	3/4	1382	1390	225	1850	1062	08	35	80	18	156	107	92	1085	119	103	875	137	.076 N°48	.05
H	1	1130	7/8	1468	1480	235	1950	1187	08	35	80	23	158	120	105	1180	131	116	1000	147	.076 N°48	.020
I	1 1/2	1450	1/2	1845	1860	275	2350	1468	08	36	80	23	161	145	130	1520	166	141	1250	185	.076 N°48	.020
J	1 1/2	1590	1/2	2200	2220	315	2700	1625	08	36	85	23	168	160	155	1750	189	166	1500	214	.076 N°48	.020

ISSUED BY
ROYAL
AIRCRAFT
ESTABLISHMENT

TITLE: MALE FLANGES, BOLTED
WITH SPIGOT - (STEEL)

DRAWN
CT Remade

TRACED
TR 26 0-65

ISSUE NO
ALTERATION NO

1
NO 10
AGE 1609

CHECKED
M. H. H. 2/22

APPROVED
M. H. H. 3/11