AIRCRAFT STANDARD PARTS

BS AGS AS

Brown Brothers Engineering Ltd

Proprietary Fasteners:

ODDIE NUTS

HI-SHEAR RIVETS

**HUCKBOLTS and
BLIND FASTENERS**



Catalogue No. 563/A



Brown Brothers Engineering Ltd

BEDFORD ROAD · NORTHAMPTON · NN1 5NP

Telephone: 0604 35181

Telegrams: Imbrowned, Northampton

Telex: Brownbro 311347



Business Arrangements and Conditions of Sale

1. ORDERS

- (a) Brown Brothers Engineering Limited (hereinafter called "the Company") reserve the right to accept telephone or telegraph orders but such orders should always be confirmed in writing the same day by the Buyer and marked "confirmation". Any orders not so marked will be treated as fresh orders and the Buyer shall be responsible for the consequences of any resulting duplication.
- (b) The Company reserves the right to refuse any order given to any representative of the Company.
- (c) In respect of all orders executed in accordance with the Buyer's drawings the Company reserves the right to supply not exceeding 10 per cent. more or less than the specified quantity.
- (d) No conditions or stipulations in or attached to the Buyer's form of order which are inconsistent with the Company's Business Arrangements or Conditions of Sale or which purport to add to or modify them in any way shall have any effect unless expressly accepted in writing by the Company. In the absence of such acceptance by the Company the Buyer shall be deemed to have withdrawn or waived his said conditions or stipulations and to contract solely on the basis of the Company's Conditions of Sale.

2. QUOTATIONS

All quotations are subject to confirmation by the Company on receipt of Buyer's official order, and no contract shall be concluded until such confirmation has been despatched by the Company.

3. CANCELLATION OF ORDERS

No cancellation of an order will be effective unless in writing and until accepted by the Company. The Company reserves the right to refuse to accept any cancellation of an order and in particular no cancellation will be accepted of orders for goods to special requirements or not normally stocked by the Company if the manufacture or obtaining by the Company of such goods is in process or has been completed.

4. PRICES

- (a) All items quoted "ex stock" are subject to prior sale.

- (b) All prices are quoted subject to revision or withdrawal without notice.
- (c) All prices in respect of orders for forward delivery are subject to the Company's right to increase them if they are affected by general increases in cost of labour or raw material or other unforeseen causes.
- (d) All prices are quoted "ex works" unless otherwise agreed and packing will be charged for, but all cases and crates returned to the Company carriage paid and in good condition within 60 days of the despatch thereof by the Company will be credited in full.
- (e) All goods will be charged for as per quotation or at prices current at the time of despatch if affected by general increases in cost of labour or raw material or other unforeseen causes and all orders are accepted by the Company on that understanding.

5. SETTLEMENT TERMS

- (a) All invoices are NET and no settlement discount is allowed.
- (b) Accounts are payable by the 20th day of the month following the date of invoice.
- (c) No special terms of payment will be operative unless confirmed in writing by the Company.
- (d) The Company reserves the right to suspend delivery in respect of any order from time to time if any account is not paid when due.

6. CARRIAGE

The Company will, if so requested and as agents for the Buyer, arrange for the carriage of goods to destinations in Great Britain, and F.O.B. nearest port for Northern Ireland and Eire. Unless otherwise instructed, goods will be sent by goods train at Railway Company's risk; the Company will pay the cost of carriage on the above basis (or an amount equal to such cost if some other method of carriage is required by the Buyer) on all consignments of £50 and upwards other than consignments of aerodrome equipment or of exceptionally bulky goods for which the carriage terms will be as quoted.

7. NON-DELIVERY AND DAMAGE IN DELIVERY

All goods will be consigned at Carriers' risk unless sent by passenger train and no liability for partial loss, damage or non-delivery will be accepted by the Company. On delivery packages should be signed for as "not examined" but if loss

Business Arrangements and Conditions of Sale

or damage is apparent they should be signed for accordingly. In the event of partial loss or damage the Buyer must (a) within three days of delivery give notice in writing to the Carriers (otherwise than on Carriers' documents) and at the same time notify the Company in writing, and (b) within seven days of delivery make a claim against the Carriers or accept any special arrangements which the Company may be able to make on the Buyer's behalf. In the event of non-delivery the Buyer must give notice in writing thereof to the Company within ten days of the date of the Company's invoice.

8. DELIVERY

The Company shall not be responsible for, nor shall the Buyer acquire any rights against the Company in respect of any failure or delay in delivery from any of the following causes:—

- (a) Failure or delay in delivery of raw materials.
- (b) Strikes, lockouts or trade disputes.
- (c) Destruction or damage (by fire or otherwise) or breakdown of machinery, plant, buildings or premises.
- (d) Breakdown or failure of electric or other power.
- (e) Breakdown in transit.
- (f) Default (including breach of contract) of sub-contractors.
- (g) War or conditions arising as the result of war or anticipated war.
- (h) Government controls and orders affecting economic or trade conditions or practices or otherwise.
- (i) Any other cause unavoidable or beyond the Company's control.

In case of delay from any of the above causes, the delivery date laid down in the contract shall be postponed for a reasonable period.

9. DELAY IN TAKING DELIVERY

If the Buyer fails or refuses to take delivery of goods on the date laid down in the contract, he shall be liable to the Company for any loss occasioned by such failure or refusal, and for any charges thereby incurred by the Company, and for a reasonable charge by the Company for the care and custody of the goods whether he has been specifically requested to take delivery of the goods or not.

10. CONDITIONS AND WARRANTIES

No warranty or condition, whether statutory or otherwise, as to the fitness of the goods to be supplied for any particular purpose in contracts subject to these Conditions of Sale is given or shall be implied and the Company is not to be liable for consequential loss or damage of any kind or description arising from any goods sold by the Company.

11. RETURN OF GOODS

No return of goods will operate to affect the liability of the Buyer under the Contract unless such return is accepted by the Company in writing and no such acceptance will be given unless previous notice of intention to return with the reason therefor and quoting reference number of Release Note, Invoice or Contents Note is given to the Company and after acceptance by the Company of such notice the goods are returned to the Company carriage paid and in good condition.

12. BREAK CLAUSE

All Tenders, Quotations and Acceptances of Orders are subject to the conditions of the Break Clauses contained in the Standard Conditions of Government Contracts for Stores Purchases current at the time.

13. EXPORT ORDERS

- (a) All export orders should be addressed to Brown Brothers (Overseas) Limited, 13-17 Tabernacle Street, London EC2A 4SQ and will be executed by them.
- (b) Unless otherwise quoted all export prices are ex-warehouse and cartage or carriage and packing will be charged to the Buyer.
- (c) If required, Brown Brothers (Overseas) Limited will be pleased to arrange shipment or Airfreight despatch at best current rates. Freight, insurance and other shipping charges will be paid by the Company and charged to the Buyer.
- (d) On despatches arranged by the Company, goods, other than dangerous or deck cargo, will be insured against all risks under the conditions mentioned on the Certificate of Insurance issued for each shipment. Claims are adjustable at destination by the agent mentioned on such Certificate who should be advised immediately in the event of a claim arising.

Alphabetical Index

A

Adaptor 247
 Adaptor Nipple ... 115, 240
 .. Union 93, 167, 168, 221,
 223, 237, 238
 Airframe Bearings 54
 Anchor Nut Assembly ... 169
 Assembly Wires 51
 Attachment Pins 203

B

Ball End, Cable ... 47, 199
 .. Joints 67, 169
 Ballast Weights ... 210, 239
 Banjo Bodies ... 109-111, 231-233
 .. Bolts 112, 113, 122, 127, 128,
 130, 228-230, 234
 .. Cone and Union G.A.
 108, 225-227
 .. Fittings, Pitot/Static ... 240
 B.A. Screws 13, 14
 Bearings, Airframe 54
 Bearings, Rod End ... 69, 70, 170
 Blank Ferrule 248
 Blanking Discs 146
 Bleeder Screw 122, 170
 Bolts, C'sk 90° Head 20, 21, 188,
 201, 204, 208

Bolts C'sk 100° Head 22, 24, 27
 .. C'sk 120° Head ... 205
 .. Dee. Head ... 254
 .. Double Hex. 26, 243, 250,
 251, 253
 .. Eye 59, 76, 77
 .. Hex. Close Tolerance ...
 12, 16-18, 198, 209
 .. Hex. Dimensions ... 5-7
 .. Hex. High Tensile Steel
 10, 12, 16-18, 24, 25, 27
 .. Hex. Alloy 12, 17, 18, 21, 22
 .. Hex. Method of Ordering
 8, 9, 12, 16
 .. Hex. Shear ... 16, 17, 18
 .. Hex. Stainless Steel ... 10, 18
 .. Mushroom Head 19, 21, 190
 201, 209, 211
 .. Pan Head ... 20, 21, 26
 .. Raised 90° C'sk Head
 189, 201, 204, 208
 .. Raised 120° C'sk Head 205
 .. Round Head 189, 201, 209,
 210, 235, 236
 Bonded Seals 125, 180
 Bonding Clips 134, 222
 .. Clip, Plain Saddle ... 222
 .. Clip Strap 222
 .. Clip, Tapped Saddle 222
 .. Lead ... 136, 160, 195, 206
 .. Socket 218
 .. Strip Screws ... 134
 .. Wire Socket ... 136
 Bulkhead, Unions, Cone Ends 96, 116

Bulkhead, Unions, Cone to
 Nipple ... 97, 117
 .. Unions, Double
 Ended 93, 97, 113, 117
 .. Unions G.A. 96, 116
 .. Screwed Sleeves ... 98
 Burrs, Rivet 49
 Bushes, Parallel Shear 186, 202
 .. Taper Shear 187
 .. Oil Retaining ... 54
 Bushing, Plastic 242

C

Cable Ball Ends 47
 .. Cleats 135, 137
 .. Clips 191
 .. Ends ... 142, 144, 145, 151
 .. End Assemblies, Swaged 58
 .. Glands 150
 .. Gland Washers ... 28
 .. Saddles 135
 .. Screwed Ends ... 42, 56
 .. Sleeves 121, 132, 133, 136-140,
 143, 145-147, 151
 .. Swaged Ends 44
 .. Tapped Ends 43, 57
 .. Union Nuts 132, 133, 138
 Cap Filler, 72, 197, 198, 199, 206
 211, 214, 218, 219, 233
 .. Protection 71, 169
 .. Sealing ... 166, 179
 Catches, Spring 49

Alphabetical Index

G—cont'd

- Channel (Nylastic Clip) ... 238
 Charging Valve ... 160, 169
 Circlips ... 55, 152, 153
 Clamp, Switch ... 135
 Cleats, Wiring ... 142, 143
 Clips, Aluminium ... 187
 .. Bonding 134, 141, 162, 222
 .. Hose ... 54, 71, 72, 89, 181
 .. Nylastic ... 209, 214
 .. Pipe 141, 157, 158, 161, 176
 .. Support ... 207, 215
 .. Speaking Tube ... 78
 .. Spring ... 194, 242
 Collar ... 196
 Collars, Pipe ... 80, 84
 .. Plain ... 75, 79
 .. (Shear Pin) ... 60
 Collet ... 140
 Cone Caps ... 118, 124, 131, 220
 Cone, Elbow ... 99
 .. Plugs ... 115, 124
 .. Tee 100, 101, 103, 126, 127
 .. Unions ... 91, 94, 96
 .. and Union Banjo 108-113,
 225-233
 .. Union Adaptor ... 92
 .. Unified Adaptor 167, 168, 220
 .. to Nipple Union ... 93
 Conical Nipples ... 65
 Connector, 4BA ... 190
 Connector, ... 172, 177
 .. Pitot ... 171, 239
 .. Static ... 171, 239
 Cord, Braided Rubber Assemblies ... 51
 Cotter Pins ... 38, 54
 Coupling Flange ... 216
 Couplings, Light Type ... 79
 .. Pipe 90, 124, 126, 129
 Coupling Adaptor ... 247
 Covers, Flange ... 164
 Cover, Lashing Fitting Base 178, 179
 Crinkle Washers ... 62
 Cup Washer, Lock ... 239
- ### D
- Dee Headed Bolts ... 254
 Discs Blanking ... 146
 Distance Tubes ... 194, 199
 Drain, Pitot ... 238
 Drain Plugs ... 66, 68, 84
 Drain Trap ... 173, 176, 177, 238
 Drain Valve ... 198
- ### E
- Elbow, Cone ... 99
 .. Nipples, End Connection ... 119
 .. Tubes ... 123, 124
 .. Unions 99, 120, 175, 223
 End Fittings, Re-Usable 130, 131, 132
 Equivalent Tables ... 181, 182
 Expanding Tool, Pipe ... 77
 Eye Bolt ... 59, 76, 77
 Eyelets and Washers ... 66
 Eyelet, Terminal ... 148
- ### F
- Ferrules ... 83, 245, 246, 248
 Ferrule Hooks ... 51, 79
 Fibre Washers ... 64, 68
 Filler Caps 72, 197-199, 206, 211,
 214, 218, 219, 233
 .. Cap Sealing Rings ... 215
 Flange, Coupling ... 216
 Flange Covers ... 164
 Flanges, Female ... 84, 85, 87, 88
 .. Male ... 86
 Flanged Mounting ... 175
 Flexible Bonding ... 160, 206
 .. Hose Assembly ... 175
 .. Strip, P.V.C. ... 198
 Fork Joints ... 29, 34, 60
- ### G
- Gasket, 'O' Ring ... 172
 Gland Nuts ... 141
 Grommets ... 45, 55
 Grub Screws ... 15
- ### H
- Hand Nuts ... 193, 217, 219
 Headless Pins ... 251
 Hinges ... 191
 Hi-Shear Riveting ... 265
 Hook Ferrule ... 51, 79
 Hose Assembly, Flexible ... 175
 .. Clip ... 54, 71, 72, 89, 181
 Huck Fastening System ... 266

Alphabetical Index

I

Identification Sleeves 133
 „ Tags 48
 Inner Sleeves 81, 84, 129, 132, 133,
 137-139
 Instrument Terminals 150

J

Joints, Ball 67, 169
 „ Fork 29, 34, 60
 Jointing Washers 64, 68, 113, 224

K

Knobs, Rotating 195

L

Lead, Bonding 136, 160, 195
 Lifting Ring 78
 Lock Nuts 65, 66, 84, 144
 „ Washer, Cup 239
 „ Washers, Shakeproof 155-156
 „ Washers, Tab 46, 58
 Locking Pin 135
 „ Rings 63, 65
 Low Pressure Unions 77, 172, 173,
 222, 223, 238
 Lubricating Nipples 40, 59, 81

N

Nipple 121, 166, 241
 „ Adaptor 115, 240
 „ Conical 65
 Nipples, Lubricating ... 40, 59, 81, 88
 Nipple Plugs 114, 127
 Nuts, Alloy 12, 15, 18, 118
 „ Assembly 248
 „ Blind Anchor 169
 „ Brass 1, 15, 24, 25
 „ Dimensions 2, 3, 4
 „ Gland 141
 „ Hand 193, 217, 219
 „ Medium Tensile Steel ... 11, 18
 „ Mild Steel 15, 25
 „ Oddie ... 21, 22, 151, 255-264
 „ Shear, High Tensile ... 16, 18
 „ Stainless Steel 10, 15, 18
 „ Union 126, 129, 132, 133
 138, 223
 „ Lock 65, 66, 84, 144
 „ Wing 63, 174

O

'O' Ring 242
 „ Gasket 172
 Oddie Stiffnuts 21, 22, 151, 255-264
 Outer Sleeves 76, 80, 84, 159, 165,
 174, 219, 220

P

'P' Section Rubber 254
 Packing Washers 201

Pins, Attachment 203
 „ Headless 251
 „ Locking 135
 „ Quick Release 197
 „ Shear 58
 „ Solid Taper 41, 50
 „ Split 38, 54, 77
 „ Split Taper 41
 „ Steel 30-32
 Pip Pins... .. 163
 Pipe Clips 141, 157, 158, 161, 170,
 176, 183, 202, 203
 „ Collars 80, 84
 „ Couplings 79, 90, 126
 „ Expanding Tools... .. 77
 Pitot Connector 171, 239
 Pitot Drain 238
 Plain Collars 75, 79
 „ Washers 38-40, 61, 238
 Plastic Bushing 242
 Plug, Cone 115, 124
 „ Drain 66, 68, 84
 „ Nipple 114, 127
 „ Reducing 75
 „ Sealing 178
 „ Transportation 130, 224
 Precision Washers 208, 242
 Protection Cap 71, 169, 179
 „ Plug 70, 163, 164, 165,
 169, 178
 Pulleys, Ball Bearing 183, 184, 188
 „ Plain 184, 190
 „ Shrouded 184, 188

Q

Quick-release Pins 197

Alphabetical Index

T—cont'd

Transportation Plug ...	130, 224
Trunnion	196, 217
Tubes, Distance ...	194, 199
Tubular Rivets... ..	67
Turnbarrels	42, 56
Turnbuckles	33, 37

U

Union Nut/Ferrule Assembly	248
.. Sleeves	112
Unions, Adaptor	93
.. Bulkhead, Cone Ends	96, 116
.. Bulkhead, Cone to Nipple	97, 117
.. Bulkhead, Double Ended	97, 117
.. Bulkhead, G.A.	96, 116
.. Cone Adaptor	92
.. Cone Ends	91, 94, 96
.. Cone to Nipple	93

Unions, Cone Unified Adaptor

	167, 168, 220
.. Double Ended	74, 84, 92
.. Elbow	99
.. Lock Nuts	65, 66, 84, 118, 144
.. Low Pressure	77, 222, 223
.. Nuts	126, 129
.. Reducing	73, 84, 94, 95
.. Tee	100-103, 126, 127
.. Unified Adaptor	168, 221
.. 4-way	104-107, 127

V

Valve, Charging ...	160, 169, 177
.. Drain	198

W

Washer Plates ...	98, 118, 125
.. Cup Lock	239

Washers, Crinkle 62

.. Jointing	64, 68, 113, 224
.. Lock Shakeproof	154, 155, 156
.. Packing	201
.. Plain	38-40, 61
.. Precision	208, 242
.. Saddle	192
.. Spring, Double Coil	48, 64
.. Spring, Single Coil	47, 64
.. Tab	46, 58
.. Thermometer ...	78
.. Thrust	55
Weight, Ballast ...	210, 239
Wing Nuts	63, 174
Wire, Hook Ferrule ...	51
.. Locking Rings ...	63, 65
.. Locking Tabs ...	208
.. Thread Inserts	218, 233, 236, 237
.. Thrust	246
Wires, Assembly ...	51
Wiring Cleats	142, 143
Wood Screws	49, 62

Numerical Index

PART NO.	PAGE	PART NO.	PAGE	PART NO.	PAGE	PART NO.	PAGE
B.S.S.		B.S.S.		B.S.		B.S.	
A14	1	3A116	9, 20	SP6	33	2SP105, 106	58
2A24	2, 10	3A117	9, 20	2SP7	34	SP107-112	46, 58
2A25	5, 8, 9, 10	A118	20	SP8	35-37	SP113	58
2A26	5, 8, 9, 11	A119	20	SP9	38, 182	SP114	59
2A27	2, 11	A120	20	SP10, 11	38	SP115-117	59
A28	12	A121	20	SP13-15	38	SP118	59
2A29	2, 12	A122-124	21, 261	SP16	39	SP119, 120	60
2A30	5, 8, 9, 12	2A125-168	21, 262	SP18, 19	39	SP121	60
A31	13	3A169	6, 8, 9, 21	SP21	40	SP122-127	61
A32	13	3A170	9, 21	SP22-27	40	SP128-133	62
A33	14	3A171	9, 21	SP28-30	41	SP134-138	62
A34	14	A172	21	SP31, 32	41		
A35	13	2A173-175	9, 22	SP33, 34	42	AGS	
A36	13	2A180, 181	22, 262	SP35, 36	43	113	63
A37	14	2A186, 187	22, 262	SP37-39	44	120	63
A38	14	2A192, 193	22, 262	SP40	45	154	63
A39	13	2A200, 201	22, 262	SP41-46	46	162	64
A40	13	2A204	23	2SP47	47	163	64
A41	14	A205	23	SP49, 50	47	164	64
A42	14	2A206	23	SP51, 52	48	165	65
A43	13	A207	23	SP53, 54	48	207	65
A44	13	2A208	23	SP55, 56	48	209	65
A45	14	A209	23	SP57, 58	49	216	66
A46	14	2A210	24	SP59, 60	49	224	66
A47 54	15	A211	24	SP61-64	49	232	66
A55 56	15	A213	262	SP65	50	385	67
2A57	7, 8, 9, 16	A214	262	SP66, 67	50	501	67
2A58	4, 16	A215	262	SP68-71	50	565, 566	68
2A59	5, 8, 9, 17	A216	262	SP72	51	567, 568	68
2A60	7, 8, 9, 17	A217-219	24	2SP73	51	575, 576	69
2A61	5, 8, 9, 17	A220	23	2SP74	51	589	69
3A102	6, 8, 9, 10, 17	A221	24	SP76-82	52	590	70
3A103	3, 11, 18	A222-225	25	SP83-85	53	591	70
3A104	6, 8, 9, 11, 18	A226	25	SP86-88	53	592	69, 70
3A105	3, 10, 18	A227, 228	26	SP89	54	593	69, 70
A106	12, 18	A229	27	SP90	54, 182	595	70
3A107	3, 12, 18	A230	27	SP91, 92	54, 181	596	71
3A108	6, 8, 9, 12, 18	A232	27	SP93	45, 55	597	71
2A109	7, 8, 9, 16, 18	B.S.		SP94	55	605	71, 181
2A110	4, 16, 18	G154	28	SP95	45, 55	606	72
3A111	6, 8, 9, 17, 18	G203	28	SP96	55	607	72
2A112	7, 8, 9, 17, 18	2SP1	29	2SP101, 102	56	626	73
3A113	9, 19	3SP3	29	2SP103, 104	57	627	74
3A114	19	5SP4	30-32			628	75
A115	19					674	75

Numerical Index

PART NO.	PAGE	PART NO.	PAGE	PART NO.	PAGE	PART NO.	PAGE
AGS		AGS		AGS		AGS	
711	76	980	87	1142	115	1519	133
771	76	981	87	1143	115	1520	133
772	77	982	87	1144	116	1521	133
773	77	986	88	1145	116	1523	133
784	77, 182	987	88	1146	117	1524	133
787	77	988	88	1147	117	1529	134
796	76, 77	995	89	1148	118	1531	134
797	76, 77	996	89	1149	118	1536	134
798	76, 77	997	89	1159	118	1538	134
799	76, 77	998	89	1165	119	1541	135
				1166	119	1542	135
				1167	120	1551	135
800	76, 77	1000	89, 181	1168	120	1562	135
801	76, 77			1169	121	1593	136
802	76, 77	1101	90	1170	121	1594	136
803	76, 77	1102	91	1173	122	1595	136
804	76, 77	1103	92	1174	122	1596	136
805	76, 77	1104	92	1175	123	1599	136
806	76, 77	1105	93	1176	123		
838	77	1106	93	1177	124		
839	78	1107	94	1178	124	1600	136
883-887	78	1108	95	1185	124	1606	136
890	78	1109	95	1186	125	1612	136
895	78	1110	96	1187	126	1615	137
897	79	1111	96	1193	126	1616	137
899	75, 79	1112	97	1194	126	1617	137
		1113	97	1195	126	1624	138
		1114	98	1196	127	1629	138
900	79	1115	98	1197	127	1630	138
902	80	1116	99	1198	127	1634	138
904	76, 80	1117	99	1199	127	1635	138
905	81	1118	100			1636	138
910	81	1119	100			1638	139
911	82	1120	101	1213	127	1639	139
912	82	1121	102	1214	128	1651	139
914	82	1122	103	1215	128	1652	139
916	82	1123	104	1216	129	1653	140
918	83	1124	104	1217	129	1654	140
920	83	1125	105	1218	129	1655	140
921	69, 83	1126	106	1218	129	1656	140
934	83	1127	107	1220	122, 130	1657	140
935	69, 83	1128	108	1229	130	1658	141
948	66, 84	1129	109	1230	130	1661	141
949	74, 84	1130	109	1234	131	1666	142
950	73, 84	1131	110	1235	131	1671	142
952	80, 84	1132	110	1236	131	1672	142
954	76, 84	1133	111	1237	132	1678	142
955	81, 84	1134	111	1238	132	1681	142
957	66, 84	1135	112			1686	143
958	84	1136	112			1687	143
959	85	1137	113	1512	132	1688	143
977	86	1138	113	1513	132	1689	143
978	86	1139	113	1516	132	1690	143
979	86	1140	114	1517	132	1691	144

Numerical Index

PART NO.	PAGE	PART NO.	PAGE	PART NO.	PAGE	PART NO.	PAGE
AGS		AGS		AGS		A.S	
1703	144	2096	160	3424	175	468	185
1704	144	2097	160	3425	175	469	186
1705	144			3429	175	483	186
1706	144			3430	175	484	187
1710	144	2100	160	3431, 3432	176	491-493	187
1713	145	2101	161	3433	176		
1714	145	2104	162	3434	176	1151	184, 188
1715	145	2105	163	3435	176	1152	184, 188
1722	145	2106	163	3436	176	1153	184, 188
1723	145	2107	163	3437	177	1154	184, 188
1724	145	2108	163	3438	177		
1725	146	2109	164	3439	177		
1726	146	2110	164	3440	177	1242	188
1727	146	2111	165			1244	189
1729	146	2112	165			1246	189
1731	146	2113	165	3500, 3501	177	1248	190
1732	147	2118	166				
1733	147	2119	166				
1734	147	2120	166				
1735	147			3800	178	1327, 1328	190
1737	148			3801	178		
1738	148	3005-3007	167	3802-3804	178	1860-1864	190
1741	148	3012	167	3805-3807	179	1865-1867	190
1744	148	3013	168	3816	179	1876-1879	191
1745	148	3016	167, 168	3820-3869	180	1880, 1881	191
1746	149	3017	168				
1747	149	3020	169	3924	181	1900	191
1748	149	3021	169	3925	181	1901	191
1749	149	3022	169			1903-1906	192
1756	150	3034	169				
1757	150	3037-3040	169			2160-2168	193
1759	150	3049	170				
1760	150	3050-3069	170	A.S		2227	185, 193
1761	151	3092	171	103-106	183, 190	2228	185, 193
1762	151	3093	171	107	184	2229	185, 193
1766	151	3094	171	108	184	2230	186, 193
1767	151	3095	171	109	184	2294	194
		3096	172	110	184	2295	194
		3097	172	111	183, 184, 190	2296	194
		3098, 3099	172	112-114	184	2297-2310	194
				155-157	185		
2001-2003	151, 256			158, 159	185	2311	195
2004-2006	151, 257			160-162	185	2312	195
2007-2009	151, 258	3401-3404	172	163-165	186	2313	195
2011	151, 258	3405	173			2314	195
2012-2014	151, 259	3406	173			2370	195
2018-2020	151, 260	3407	173			2381-2383	196
2030	152	3408	173	455	185	2384-2392	196
2031	153	3409	173	457-459	185	2393-2395	196
2034	154	3412	173	460	185	2398	197
2035	155	3413	174	462	185		
2036	156	3414	174	463	186		
2037	156	3420, 3421	175	465	186		
2080, 2081	157	3422	175	466	185	2434-2438	197
2082, 2083	158	3423	175	467	185	2439-2443	197
2085	159						

Numerical Index

PART NO.	PAGE	PART NO.	PAGE	PART NO.	PAGE	PART NO.	PAGE
A.S.		A.S.		A.S.		A.S.	
2444, 2445	197	4647, 4648	213	6716	224	8679	239
		4676-4693	214	6717	224	8690-8699	239
2504	198	4694	185, 214	6720	225-227	10700	240
2505	198	4695	185, 214	6721	228	10701	241
2506	198	4696	186, 214	6722	228		
2510	197, 198			6723	229	12800-12801	242
2573	198	4716	214	6724	229	12810-12839	242
2590	199	4749, 4750	214	6725	230	12840-12869	242
				6726	230	12870-12889	242
2806-2811	199	5364	215	6727	231	12890-12939	242
				6728	231		
2902, 2903	199	5401-5415	215	6729	231	12940-12959	242
2904, 2905	199	5418, 5419	207, 215	6730	232	13000-14199	243
2918	200	5440-5457	216	6731	232		
2919	200	5459-5476	216	6732	233	14500-15699	243
2920	188, 201			6733	233		
2921	189, 201	6210-6212	217	6734	233	15700-15711	244
2922	189, 201	6213-6218	217	6742, 6743	233	15724-15743	245
2923	190, 201	6241	217	6758	234	15766-15769	246
				6759	234	15776-15787	246
3031-3036	201	6316, 6317	218	6760-6804	235		
		6318, 6319	218			15800-15823	247
3119	202			6850-6894	235	15824-15835	248
3180	202	6322, 6323	218	6895-6939	235	15836-15847	248
3181	203	6327, 6328	218				
		6348	218	6985-7032	235	16000-16399	249
3281-3824	203	6357	218				
3294	204	6398	219	7033-7077	235	16400-16799	249
3295	204	6399	219				
3296	205					17000-18199	250
3297	205	6541, 6542	219				
				7123-7170	236	18200-19399	250
3360	206			7171-7215	236		
3362	200, 206	6609, 6610	217, 219			19400-20599	251
3363	200, 206	6687	219	7264-7308	236		
3365, 3366	206	6688	220			20640-20739	251
		6689	220	8451	236		
4525, 4526	207	6690	220	8452	236	20740-20759	251
4561	208	6691	220	8455	237	20761-20765	252
4562	208	6692	221	8456	237		
4563	188, 208	6693	220			20800-30796	252
4564	189, 208	6694	221	8589	237		
4565	189, 209			8590	237	22400-23799	253
4566	190, 209	6702, 6703	222	8591	237		
4569	209	6704	222	8592	238	23900-25296	253
4580	209	6705	222	8595	238		
4581	209	6706	222	8597	238	26100-27299	254
4589	210	6707	222	8599	238		
4590	210	6709	222			28100-28699	254
4597	210	6710	223				
4598	211	6711	223			28950-28959	254
		6712	223	8646	238		
		6713	223	8662	239	30816-31396	253
4641, 4642	211	6714	223	8666	239		
4645, 4646	212	6715	223			31415-31996	253

Brown Brothers Engineering Ltd

B.S. A14

NUTS (Brass)

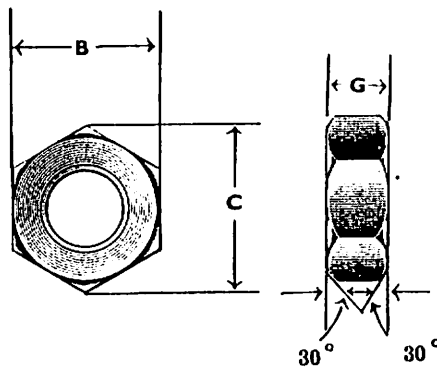

Material : BRASS

Finish : AS REQUIRED

NOMINAL SIZE	PART NO.		B		C	G		
	RIGHT HAND THREAD	LEFT HAND THREAD	MIN.	MAX.	MAX.	MIN.	MAX.	
			IN.	IN.	IN.	IN.	IN.	
0 BA	0 B	0 BL	0-110	0-113	0-48	0-226	0-236	
1 BA	1 B	1 BL	0-362	0-365	0-42	0-199	0-209	
2 BA	2 B	2 BL	0-321	0-324	0-37	0-175	0-185	
4 BA	4 B	4 BL	0-245	0-248	0-29	0-132	0-142	
6 BA	6 B	6 BL	0-190	0-193	0-22	0-100	0-110	
8 BA	8 B	8 BL	0-150	0-152	0-18	0-082	0-087	
10 BA	10 B	10 BL	0-115	0-117	0-14	0-062	0-067	
Replaced by A51.	4 BA	BB	BBL	0-245	0-248	0-29	0-08	0-09
	2 BA	CB	CHL	0-321	0-324	0-37	0-10	0-11
	1" BSF	EB	EHL	0-138	0-145	0-51	0-12	0-13
	3/4" BSF	GB	GBL	0-518	0-525	0-61	0-14	0-15
	1/2" BSF	JB	JBL	0-592	0-600	0-69	0-15	0-16
	3/8" BSF	LB	LBL	0-702	0-710	0-82	0-17	0-18
	1/4" BSF	NB	NBL	0-812	0-820	0-95	0-19	0-20
	5/16" BSF	PB	PBL	0-912	0-920	1-06	0-19	0-20
	3/16" BSF	QB	QBL	1-002	1-010	1-17	0-21	0-22
	1/8" BSF	RB	RBL	1-092	1-100	1-27	0-23	0-24
	7/16" BSF	SB	SBL	1-192	1-200	1-39	0-25	0-26
	1/2" BSF	TB	TBL	1-192	1-200	1-39	0-27	0-28
	5/8" BSF	UB	UBL	1-288	1-300	1-5	0-29	0-30
	3/4" BSF	VB	VBL	1-382	1-390	1-61	0-31	0-32
	1" BSF	WB	WBL	1-468	1-480	1-71	0-33	0-34
	1 1/4" BSF	XB	XBL	1-658	1-670	1-93	0-38	0-39
1 1/2" BSF	YB	YBL	1-845	1-860	2-15	0-43	0-44	

Brown Brothers Engineering Ltd

NUTS—ORDINARY, THIN, SLOTTED AND CASTLE BA & BSF—B.S. 2A24, 2A27 & 2A29



Ordinary



Thin



Slotted



Castle

Material identification grooves on B.S. 2A24 & B.S. 2A27 only

PRINCIPAL DIMENSIONS—IN.

NOM. SIZE	A/P		A/C MAX.	ORDINARY	THIN	SLOTTED			CASTLE		
	MIN.	MAX.		G MAX.	G MAX.	G MAX.	L MAX.	SPLIT PIN DIA.	M MAX.	G MAX.	SPLIT PIN DIA.
6 BA	0.188	0.193	0.22	0.105	0.073	—	—	—	—	—	—
4 BA	0.243	0.248	0.29	0.135	0.094	—	—	—	—	—	—
2 BA	0.319	0.324	0.37	0.167	0.123	0.250	0.160	1/8"	—	—	—
1" BSF	0.438	0.445	0.51	0.200	0.133	0.260	0.170	1/8"	0.290	0.200	1/8"
3/4" BSF	0.518	0.525	0.61	0.250	0.166	0.280	0.190	1/8"	0.340	0.250	1/8"
1/2" BSF	0.592	0.600	0.69	0.312	0.208	0.312	0.222	1/8"	0.402	0.312	1/8"
3/8" BSF	0.702	0.710	0.82	0.375	0.250	0.375	0.235	3/16"	0.515	0.375	3/16"
1/4" BSF	0.812	0.820	0.95	0.437	0.291	0.437	0.297	3/16"	0.577	0.437	3/16"
3/16" BSF	0.912	0.920	1.06	0.500	0.333	0.500	0.313	1/4"	0.687	0.500	1/4"
1" BSF	1.000	1.010	1.17	0.562	0.375	0.562	0.375	1/4"	0.749	0.562	1/4"
1/2" BSF	1.190	1.200	1.39	0.687	0.468	0.687	0.453	3/8"	0.921	0.687	3/8"
1" BSF	1.288	1.300	1.50	0.750	0.500	0.750	0.616	3/8"	0.984	0.750	3/8"
1" BSF	1.468	1.480	1.71	0.875	0.583	0.875	0.695	3/8"	1.155	0.875	3/8"

Brown Brothers Engineering Ltd

NUTS—ORDINARY, THIN, SLOTTED AND CASTLE

UNIFIED—B.S. 3A103, 3A105 & 3A107



Ordinary



Thin



Slotted



Castle

PRINCIPAL DIMENSIONS—IN.

NOMINAL SIZE	A/P		A/C MAX.	ORDINARY	THIN	SLOTTED			CASTLE		
	MIN.	MAX.		G MAX.	G MAX.	G MAX.	L MAX.	SPLIT PIN DIA.	M MAX.	G MAX.	SPLIT PIN DIA.
No. 4-40 UNC	0.183	0.188	0.217	0.105	0.073	—	—	—	—	—	—
No. 6-32 UNC	0.215	0.250	0.289	0.125	0.089	—	—	—	—	—	—
No. 8-32 UNC	0.307	0.312	0.361	0.155	0.113	—	—	—	—	—	—
No. 10-32 UNF	0.339	0.311	0.397	0.167	0.123	0.250	0.160	1/16"	—	—	—
1/4" UNF	0.431	0.438	0.505	0.200	0.133	0.260	0.170	1/16"	0.290	0.200	3/16"
5/16" UNF	0.493	0.500	0.577	0.250	0.166	0.280	0.190	1/16"	0.340	0.250	1/8"
3/8" UNF	0.551	0.562	0.650	0.312	0.208	0.312	0.222	1/16"	0.402	0.312	1/8"
1/2" UNF	0.679	0.688	0.794	0.375	0.250	0.375	0.235	3/32"	0.515	0.375	3/16"
5/8" UNF	0.711	0.750	0.866	0.437	0.291	0.437	0.297	3/16"	0.577	0.437	3/16"
3/4" UNF	0.866	0.875	1.010	0.500	0.333	0.600	0.313	1/8"	0.687	0.500	1/4"
7/8" UNF	0.929	0.938	1.083	0.562	0.375	0.562	0.375	1/8"	0.749	0.562	1/4"
1" UNF	1.052	1.062	1.227	0.687	0.458	0.687	0.453	3/16"	0.921	0.687	3/16"
1 1/8" UNF	1.240	1.250	1.443	0.750	0.500	0.750	0.516	3/16"	0.984	0.750	3/16"
1 1/4" UNF	1.426	1.438	1.660	0.875	0.583	0.875	0.595	3/16"	1.165	0.875	3/16"

Brown Brothers Engineering Ltd

NUTS FOR SHEAR BOLTS—THIN AND SLOTTED

BSF—B.S. 2A58

UNIFIED—B.S. 2A110



Thin



Slotted

Material Identification Grooves on B.S. 2A58 only.

PRINCIPAL DIMENSIONS—IN.

Nom. Size	A/P		A/C MAX.	THIN G MAX.	SLOTTED		SPLIT PIN DIA.
	MIN.	MAX.			G MAX.	L MAX.	
$\frac{1}{4}$ " BSF	0.438	0.445	0.51	—	0.20	0.11	$\frac{1}{16}$ "
$\frac{5}{16}$ " BSF	0.438	0.445	0.51	0.20	0.20	0.11	$\frac{1}{16}$ "
$\frac{3}{8}$ " BSF	0.518	0.525	0.61	0.20	0.20	0.11	$\frac{1}{16}$ "
$\frac{7}{16}$ " BSF	0.592	0.600	0.69	0.20	0.20	0.11	$\frac{1}{16}$ "
$\frac{1}{2}$ " BSF	0.702	0.710	0.82	0.20	0.20	0.11	$\frac{1}{16}$ "
$\frac{9}{16}$ " BSF	0.812	0.820	0.95	0.20	0.20	0.11	$\frac{1}{16}$ "
$\frac{5}{8}$ " BSF	0.912	0.920	1.06	0.20	0.20	0.11	$\frac{3}{32}$ "
$\frac{3}{4}$ " BSF	1.000	1.010	1.17	0.20	0.20	0.11	$\frac{3}{32}$ "

$\frac{1}{4}$ " BSF thin nuts should be ordered to B.S. 2A27 Part No. 2A27/ET

$\frac{1}{4}$ " UNF	0.370	0.375	0.433	0.20	0.20	0.11	$\frac{1}{16}$ "
$\frac{5}{16}$ " UNF	0.431	0.438	0.505	0.20	0.20	0.11	$\frac{1}{16}$ "
$\frac{3}{8}$ " UNF	0.493	0.500	0.577	0.20	0.20	0.11	$\frac{1}{16}$ "
$\frac{7}{16}$ " UNF	0.554	0.562	0.650	0.20	0.20	0.11	$\frac{1}{16}$ "
$\frac{1}{2}$ " UNF	0.679	0.688	0.794	0.20	0.20	0.11	$\frac{1}{16}$ "
$\frac{9}{16}$ " UNF	0.741	0.750	0.866	0.20	0.20	0.11	$\frac{1}{16}$ "
$\frac{5}{8}$ " UNF	0.866	0.875	1.010	0.20	0.20	0.11	$\frac{3}{32}$ "
$\frac{3}{4}$ " UNF	0.929	0.938	1.083	0.20	0.20	0.11	$\frac{3}{32}$ "

HEXAGON HEADED BOLTS

BA & BSF—B.S. 2A25, 2A26, 2A30, 2A59 & 2A61

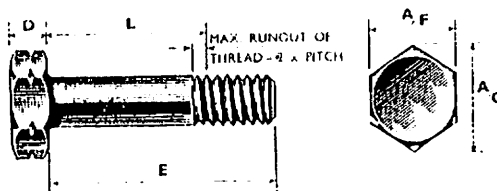

PRINCIPAL DIMENSIONS—IN.

(For method of ordering, see pages 8 and 9)

ITEM	NOMINAL SIZE	A/F		A/C	E	D
		MIN.	MAX.	MAX.	MIN.	MAX.
A	6 BA	0.188	0.193	0.22	1.4 ± 0.35	0.068
B	4 BA	0.243	0.248	0.29	1.4 ± 0.40	0.086
C	2 BA	0.319	0.324	0.37	1.4 ± 0.45	0.113
E	1/4" BSF	0.438	0.445	0.51	1.4 ± 0.50	0.150
G	5/16" BSF	0.518	0.525	0.61	1.4 ± 0.55	0.180
J	3/8" BSF	0.592	0.600	0.69	1.4 ± 0.65	0.220
L	7/16" BSF	0.702	0.710	0.82	1.4 ± 0.70	0.270
N	1/2" BSF	0.812	0.820	0.95	1.4 ± 0.80	0.300
P	5/8" BSF	0.912	0.920	1.06	1.4 ± 0.85	0.350
Q	3/4" BSF	1.000	1.010	1.17	1.4 ± 0.95	0.390
S	7/8" BSF	1.190	1.200	1.39	1.4 ± 1.255	0.480
U	1" BSF	1.288	1.300	1.50	1.4 ± 1.455	0.530
W	1 1/8" BSF	1.468	1.480	1.71	1.4 ± 1.555	0.620

N.B.—The head thickness "D" for B.S. 2A30 and B.S. 2A59 bolts is 0.030" smaller than the figures tabulated.

Aluminium alloy bolts B.S. 2A61 have no material identification grooves on hexagons.

HEXAGON HEADED BOLTS

UNIFIED—B.S. 3A102, 3A104, 3A108, 3A111, & 3A169

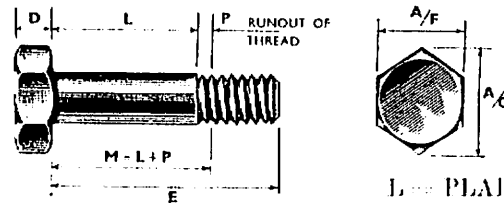

L = PLAIN LENGTH
M = CLAMPING LENGTH

PRINCIPAL DIMENSIONS—IN.

(For method of ordering, see pages 8 and 9)

ITEM	NOMINAL SIZE	A/F		A/C MAX.	P MAX. 2 × PITCH	E MIN.	D MAX.
		MIN.	MAX.				
A	No. 4-40 UNC	0.183	0.188	0.217	0.050	M + 0.350	0.070
B	No. 6-32 UNC	0.245	0.250	0.289	0.063	M + 0.337	0.085
C	No. 8-32 UNC	0.307	0.312	0.361	0.063	M + 0.387	0.100
D	No. 10-32 UNF	0.339	0.344	0.397	0.063	M + 0.437	0.115
E	1/4" UNF	0.431	0.438	0.505	0.071	M + 0.529	0.150
G	5/16" UNF	0.493	0.500	0.577	0.083	M + 0.567	0.180
J	3/8" UNF	0.554	0.562	0.650	0.083	M + 0.667	0.220
L	7/16" UNF	0.679	0.688	0.794	0.100	M + 0.750	0.270
N	1/2" UNF	0.741	0.750	0.866	0.100	M + 0.850	0.300
P	5/8" UNF	0.866	0.875	1.010	0.111	M + 0.939	0.350
Q	3/4" UNF	0.929	0.938	1.083	0.111	M + 1.039	0.390
S	7/8" UNF	1.052	1.062	1.227	0.125	M + 1.225	0.480
U	1" UNF	1.240	1.250	1.443	0.143	M + 1.407	0.530
W	1" UNF	1.426	1.438	1.660	0.167	M + 1.583	0.620

Brown Brothers Engineering Ltd

HEXAGON HEADED SHEAR BOLTS BSF—B.S. 2A57, 2A60

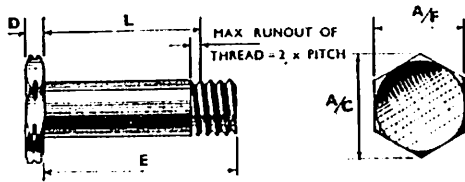

PRINCIPAL DIMENSIONS—IN.
(For method of ordering, see pages 8 and 9)

ITEM	NOMINAL SIZE	A/F		A/C	E	D
		MIN.	MAX.	MAX.	MIN.	MAX.
E	1" BSF	0.319	0.324	0.37	L + 0.34	0.130
G	5/16" BSF	0.438	0.445	0.51	L + 0.34	0.130
J	3/8" BSF	0.518	0.525	0.61	L + 0.34	0.130
L	7/16" BSF	0.592	0.600	0.69	L + 0.35	0.130
N	1/2" BSF	0.702	0.710	0.82	L + 0.35	0.130
P	5/8" BSF	0.812	0.820	0.95	L + 0.35	0.130
Q	3/4" BSF	0.912	0.920	1.06	L + 0.36	0.130
S	7/8" BSF	1.000	1.010	1.17	L + 0.38	0.130

HEXAGON HEADED SHEAR BOLTS UNIFIED—B.S. 2A109, 2A112

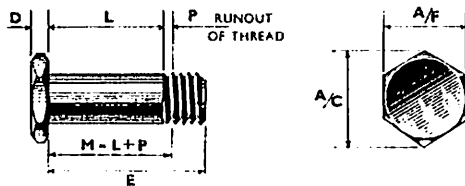

L = PLAIN LENGTH
M = CLAMPING LENGTH

PRINCIPAL DIMENSIONS—IN.
(For method of ordering, see pages 8 and 9)

ITEM	NOMINAL SIZE	A/F		A/C	P	E	D
		MIN.	MAX.	MAX.	MAX. 2 x PITCH	MIN.	MAX.
E	1" UNF	0.370	0.375	0.433	0.071	M + 0.329	0.130
G	5/16" UNF	0.431	0.438	0.505	0.083	M + 0.327	0.130
J	3/8" UNF	0.493	0.500	0.577	0.083	M + 0.327	0.130
L	7/16" UNF	0.554	0.562	0.650	0.100	M + 0.340	0.130
N	1/2" UNF	0.679	0.688	0.794	0.100	M + 0.340	0.130
P	5/8" UNF	0.741	0.750	0.866	0.111	M + 0.339	0.130
Q	3/4" UNF	0.866	0.875	1.010	0.111	M + 0.349	0.130
S	7/8" UNF	0.929	0.938	1.083	0.125	M + 0.365	0.130

Brown Brothers Engineering Ltd

HEXAGON HEADED BOLTS & SHEAR BOLTS BA & BSF—B.S. 2A25, 2A26, 2A30, 2A57, 2A59, 2A60 & 2A61 UNIFIED—B.S. 3A102, 3A104, 3A108, 2A109, 3A111, 2A112 & 3A169

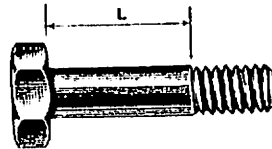

METHOD OF ORDERING

(For principal dimensions, see pages 5-7)

ITEM	A	B	C	D	E	G	J
NOM. SIZE	6 BA OR No. 4-40 UNC	4 BA OR No. 6-32 UNC	2 BA OR No. 8-32 UNC	No. 10-32 UNF	$\frac{1}{4}$ " BSF OR $\frac{1}{4}$ " UNF	$\frac{5}{16}$ " BSF OR $\frac{5}{16}$ " UNF	$\frac{3}{8}$ " BSF OR $\frac{3}{8}$ " UNF
ITEM	L	N	P	Q	S	U	W
NOM. SIZE	$\frac{7}{16}$ " BSF OR $\frac{7}{16}$ " UNF	$\frac{1}{2}$ " BSF OR $\frac{1}{2}$ " UNF	$\frac{9}{16}$ " BSF OR $\frac{9}{16}$ " UNF	$\frac{5}{8}$ " BSF OR $\frac{5}{8}$ " UNF	$\frac{3}{4}$ " BSF OR $\frac{3}{4}$ " UNF	$\frac{7}{8}$ " BSF OR $\frac{7}{8}$ " UNF	1" BSF OR 1" UNF

Bolts to the above specifications are ordered by the British Standard Number, followed by a number indicating the nominal length of plain shank "L" in tenths of an inch, followed by the item letter indicating the nominal size.

EXAMPLE :

- (i) A 2BA- 2A25 bolt with a plain length "L" of 0.7" would be 2A25/7C.
- (ii) A $\frac{5}{16}$ " BSF- 2A60 bolt with a plain length "L" of 1.8" would be 2A60/18G.
- (iii) A $\frac{1}{2}$ " UNF-3A104 bolt with a plain length "L" of 3.2" would be 3A104/32N.

Brown Brothers Engineering Ltd

TABLE SHOWING METHOD OF CALCULATION OF OVERALL AND PLAIN LENGTHS OF STANDARD BOLTS

To find Nominal Plain Length subtract figure in Col. 1 from minimum overall length.

To find Minimum Overall Length add figure in Col. 1 to nominal plain length.

(Plain length is always a multiple of $\frac{1}{16}$ of an inch "nominal".)

2A25, 2A28, 2A30, 2A59, 2A61

ITEM LETTER	THREAD SIZE	COL. 1
A	6 BA	0.35"
B	4 BA	0.40"
C	2 BA	0.45"
E	$\frac{1}{4}$ " BSF	0.50"
G	$\frac{5}{16}$ " BSF	0.55"
J	$\frac{3}{8}$ " BSF	0.65"
L	$\frac{7}{16}$ " BSF	0.70"
N	$\frac{1}{2}$ " BSF	0.80"
P	$\frac{9}{16}$ " BSF	0.85"
Q	$\frac{5}{8}$ " BSF	0.95"
S	$\frac{3}{4}$ " BSF	1.255"
U	$\frac{7}{8}$ " BSF	1.455"
W	1" BSF	1.555"

2A109, 2A112

ITEM LETTER	THREAD SIZE	COL. 1
E	$\frac{1}{4}$ " UNF	0.400"
G	$\frac{5}{16}$ " UNF	0.410"
J	$\frac{3}{8}$ " UNF	0.410"
L	$\frac{7}{16}$ " UNF	0.440"
N	$\frac{1}{2}$ " UNF	0.440"
P	$\frac{9}{16}$ " UNF	0.450"
Q	$\frac{5}{8}$ " UNF	0.460"
S	$\frac{3}{4}$ " UNF	0.490"

2A57, 2A60

ITEM LETTER	THREAD SIZE	COL. 1
E	$\frac{1}{4}$ " BSF	0.34"
G	$\frac{5}{16}$ " BSF	0.34"
J	$\frac{3}{8}$ " BSF	0.34"
L	$\frac{7}{16}$ " BSF	0.35"
N	$\frac{1}{2}$ " BSF	0.35"
P	$\frac{9}{16}$ " BSF	0.35"
Q	$\frac{5}{8}$ " BSF	0.36"
S	$\frac{3}{4}$ " BSF	0.38"

3A102, 3A104, 3A108, 3A111, 3A113, 3A116, 3A117, 3A169, 3A170, 3A171, 2A173, 2A174, 2A175

ITEM LETTER	THREAD SIZE	COL. 1
A	No. 4-40 UNC	0.400"
B	No. 6-32 UNC	0.400"
C	No. 8-32 UNC	0.450"
D	No. 10-32 UNF	0.500"
E	$\frac{1}{4}$ " UNF	0.600"
G	$\frac{5}{16}$ " UNF	0.650"
J	$\frac{3}{8}$ " UNF	0.750"
L	$\frac{7}{16}$ " UNF	0.850"
N	$\frac{1}{2}$ " UNF	0.950"
P	$\frac{9}{16}$ " UNF	1.050"
Q	$\frac{5}{8}$ " UNF	1.150"
S	$\frac{3}{4}$ " UNF	1.350"
U	$\frac{7}{8}$ " UNF	1.550"
W	1" UNF	1.750"

Brown Brothers Engineering Ltd

HIGH TENSILE STAINLESS STEEL NUTS BA & BSF—B.S. 2A24 UNIFIED—B.S. 3A105 (Replacing A16Z)

ORDINARY, THIN, SLOTTED AND CASTLE

(For principal dimensions, see pages 2 and 3)

NOM. SIZE	PART NUMBERS							
	ORDINARY		THIN		SLOTTED		CASTLE	
	RIGHT HAND THREAD	LEFT HAND THREAD	RIGHT HAND THREAD	LEFT HAND THREAD	RIGHT HAND THREAD		RIGHT HAND THREAD	
6 BA or No. 4-40 UNC	AP	APL	AT	ATL	—		—	
4 BA or No. 6-32 UNC	BP	BPL	BT	BTL	—		—	
2 BA	CP	CPL	CT	CTL	CS		—	
No. 8-32 UNC	CP	CPL	CT	CTL	—		—	
No. 10-32 UNF	DP	DPL	DT	DTL	DS		—	
$\frac{1}{4}$ " BSF or $\frac{1}{4}$ " UNF	EP	EPL	ET	ETL	ES		EC	
$\frac{5}{16}$ " BSF or $\frac{5}{16}$ " UNF	GP	GPL	GT	GTL	GS		GC	
$\frac{3}{8}$ " BSF or $\frac{3}{8}$ " UNF	JP	JPL	JT	JTL	JS		JC	
$\frac{7}{16}$ " BSF or $\frac{7}{16}$ " UNF	LP	LPL	LT	LTL	LS		LC	
$\frac{1}{2}$ " BSF or $\frac{1}{2}$ " UNF	NP	NPL	NT	NTL	NS		NC	
$\frac{9}{16}$ " BSF or $\frac{9}{16}$ " UNF	PP	PPL	PT	PTL	PS		PC	
$\frac{5}{8}$ " BSF or $\frac{5}{8}$ " UNF	QP	QPL	QT	QTL	QS		QC	
$\frac{3}{4}$ " BSF or $\frac{3}{4}$ " UNF	SP	SPL	ST	STL	SS		SC	
$\frac{7}{8}$ " BSF or $\frac{7}{8}$ " UNF	UP	UPL	UT	UTL	US		UC	
1" BSF or 1" UNF	WP	WPL	WT	WTL	WS		WC	

METHOD OF ORDERING

The specification number is suffixed by the part number, e.g. :—

A $\frac{1}{4}$ " BSF ordinary nut with a right-hand thread would be 2A24/EP, or with a left-hand thread 2A24/EPL.

A $\frac{3}{8}$ " UNF thin nut with a right-hand thread would be 3A105/JT, or with a left-hand thread 3A105/JTL.

HIGH TENSILE STEEL BOLTS BA & BSF—B.S. 2A25 UNIFIED—B.S. 3A102 (Replacing 2A15Y and 6A1)

(CADMIUM)

Over $\frac{5}{8}$ " nominal size normally supplied in increments of $\frac{1}{8}$ " only.

(For principal dimensions and method of ordering, see pages 5, 6, 8 and 9)

Brown Brothers Engineering Ltd

HIGH TENSILE STAINLESS STEEL BOLTS BA & BSF—B.S. 2A26 UNIFIED—B.S. 3A104

(Replacing 2A15Z)

Over $\frac{5}{8}$ " nominal size normally supplied in increments of $\frac{1}{8}$ " only.

(For principal dimensions and method of ordering, see pages 5, 6, 8 and 9)

MEDIUM TENSILE STEEL NUTS

BA & BSF—B.S. 2A27

(Replacing A16Y)

UNIFIED—B.S. 3A103

(CADMIUM)

ORDINARY, THIN, SLOTTED and CASTLE

(For principal dimensions, see pages 2 and 3)

NOMINAL SIZE	PART NUMBERS							
	ORDINARY		THIN		SLOTTED		CASTLE	
	RIGHT HAND THREAD	LEFT HAND THREAD	RIGHT HAND THREAD	LEFT HAND THREAD	RIGHT HAND THREAD		RIGHT HAND THREAD	
6 BA or No. 4-40 UNC	AP	APL	AT	ATL	—		—	
4 BA or No. 6-32 UNC	BP	BPL	BT	BTL	—		—	
2 BA	CP	CPL	CT	CTL	CS		—	
No. 8-32 UNC	CP	CPL	CT	CTL	—		—	
No. 10-32 UNF	DP	DPL	DT	DTL	DS		—	
$\frac{1}{4}$ " BSF or $\frac{1}{4}$ " UNF	EP	EPL	ET	ETL	ES		EC	
$\frac{5}{16}$ " BSF or $\frac{5}{16}$ " UNF	GP	GPL	GT	GTL	GS		GC	
$\frac{3}{8}$ " BSF or $\frac{3}{8}$ " UNF	JP	JPL	JT	JTL	JS		JC	
$\frac{1}{2}$ " BSF or $\frac{1}{2}$ " UNF	LP	LPL	LT	LTL	LS		LC	
$\frac{3}{4}$ " BSF or $\frac{3}{4}$ " UNF	NP	NPL	NT	NTL	NS		NC	
$\frac{7}{8}$ " BSF or $\frac{7}{8}$ " UNF	PP	PPL	PT	PTL	PS		PC	
1" BSF or 1" UNF	QP	QPL	QT	QTL	QS		QC	
$\frac{1}{2}$ " BSF or $\frac{1}{2}$ " UNF	SP	SPL	ST	STL	SS		SC	
$\frac{3}{4}$ " BSF or $\frac{3}{4}$ " UNF	UP	UPL	UT	UTL	US		UC	
1" BSF or 1" UNF	WP	WPL	WT	WTL	WS		WC	

METHOD OF ORDERING

The specification number is suffixed by the part number., e.g. :—

A $\frac{1}{4}$ " BSF ordinary nut with a right-hand thread would be 2A27/EP, or with a left-hand thread 2A27/EPL.

A $\frac{3}{8}$ " UNF thin nut with a right-hand thread would be 3A103/JT, or with a left-hand thread 3A103/JTL.

Brown Brothers Engineering Ltd

ALUMINIUM ALLOY BOLTS (Anodised)
BA & BSF—B.S. A28 UNIFIED—B.S. A106
 (Replaced by 2A61) (Replaced by 3A169)
 (Replacing A17)

ALUMINIUM ALLOY NUTS (Anodised)
BA & BSF—B.S. 2A29 UNF—B.S. 3A107
 (Replacing A18)

ORDINARY AND SLOTTED

(For principal dimensions, see pages 2 and 3)

NOMINAL SIZE	PART NUMBERS				NOMINAL SIZE	PART NUMBERS			
	ORDINARY		SLOTTED			ORDINARY		SLOTTED	
	RIGHT-HAND THREAD	LEFT-HAND THREAD	RIGHT-HAND THREAD			RIGHT-HAND THREAD	LEFT-HAND THREAD	RIGHT-HAND THREAD	
4 BA or No. 6-32 UNC	BP	BPL	---		$\frac{1}{2}$ " BSF or $\frac{1}{2}$ " UNF	JP	JPL	JS	
2 BA or No. 8-32 UNC	CP	CPL	---		$\frac{3}{8}$ " BSF or $\frac{3}{8}$ " UNF	LP	LPL	LS	
No. 10-32 UNF	DP	DPL	---		$\frac{1}{2}$ " BSF or $\frac{1}{2}$ " UNF	NP	NPL	NS	
$\frac{1}{4}$ " BSF or $\frac{1}{4}$ " UNF	EP	EPL	ES		$\frac{3}{8}$ " BSF or $\frac{3}{8}$ " UNF	PP	PPL	PS	
$\frac{5}{16}$ " BSF or $\frac{5}{16}$ " UNF	GP	GPL	GS		$\frac{1}{2}$ " BSF or $\frac{1}{2}$ " UNF	QP	QPL	QS	

METHOD OF ORDERING

The specification number is suffixed by the part number, e.g. :—

A $\frac{1}{4}$ " BSF ordinary nut with a right-hand thread would be 2A29/EP, or with a left-hand thread 2A29/EPL.

A $\frac{3}{8}$ " UNF ordinary nut with a right-hand thread would be 3A107/JP, or with a left-hand thread 3A107/JPL.

CLOSE TOLERANCE HIGH TENSILE STEEL BOLTS

BA & BSF—B.S. 2A30 UNF—B.S. 3A108

(Head and Thread—CADMIUM. Plain Shank and underside of Head—
 TEMPORARY RUST PREVENTATIVE)

NOMINAL SIZE	2 BA		No. 10-32 UNF		$\frac{1}{2}$ " BSF or $\frac{1}{2}$ " UNF		$\frac{5}{16}$ " BSF or $\frac{5}{16}$ " UNF	
	MIN.	MAX.	MIN.	MAX.	MIN.	MAX.	MIN.	MAX.
PLAIN SHANK DIAMETER—IN.	0.18675	0.18725	0.18905	0.18955	0.24925	0.24975	0.31175	0.31225
NOMINAL SIZE	$\frac{1}{2}$ " BSF or $\frac{1}{2}$ " UNF		$\frac{3}{8}$ " BSF or $\frac{3}{8}$ " UNF		$\frac{1}{2}$ " BSF or $\frac{1}{2}$ " UNF			
	MIN.	MAX.	MIN.	MAX.	MIN.	MAX.		
PLAIN SHANK DIAMETER—IN.	0.37425	0.37475	0.43675	0.43725	0.49925	0.49975		

(For other dimensions and method of ordering, see pages 5, 6; 8 and 9)

Brown Brothers Engineering Ltd

B.S. A31, A35, A39, A43

Replacing : AGS 247
(MILD STEEL)

B.A. CHEESE HEAD SCREWS

AGS 896 (STAINLESS STEEL) AGS 246 (BRASS)

Material :

A31 MILD STEEL (Cadmium)

A35 STAINLESS STEEL (Self)

A39 ALUMINIUM ALLOY (Anodised)

A43 BRASS (Electro-tinned)

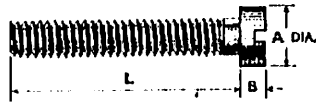

ITEM	SIZE	A		B	
		MAX.	MIN.	MAX.	MIN.
C	2 BA	IN. 0.319	IN. 0.309	IN. 0.130	IN. 0.123
B	4 BA	0.252	0.242	0.101	0.095
A	6 BA	0.194	0.184	0.078	0.073
Z	8 BA	0.157	0.147	0.063	0.059
Y	10 BA	0.112	0.107	0.045	0.041
X	12 BA	0.095	0.090	0.038	0.035

METHOD OF ORDERING

The part reference number consists of the item letter followed by the item number which represents the nominal length "L" in $\frac{1}{32}$ of an inch.

The complete part number for a 4BA aluminium alloy cheese head screw with a nominal length "L" of $\frac{1}{2}$ " is therefore A39/B16.

B.S. A32, A36, A40, A44

Replacing : AGS 245
(MILD STEEL)

AGS 967 (STAINLESS STEEL)

AGS 564 (AL. ALLOY)

AGS 244 (BRASS)

Material :

A32 MILD STEEL (Cadmium)

A36 STAINLESS STEEL (Self)

A40 ALUMINIUM ALLOY (Anodised)

A44 BRASS (Electro-tinned)

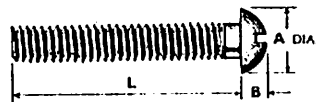

ITEM	SIZE	A		B	
		MAX.	MIN.	MAX.	MIN.
B	2 BA	IN. 0.319	IN. 0.309	IN. 0.130	IN. 0.123
B	4 BA	0.252	0.242	0.101	0.095
A	6 BA	0.194	0.184	0.078	0.073
Z	8 BA	0.157	0.147	0.063	0.059
Y	10 BA	0.112	0.107	0.045	0.041

METHOD OF ORDERING

The part reference number consists of the item letter followed by the item number which represents the nominal length "L" in $\frac{1}{32}$ of an inch.

The complete part number for a 4BA aluminium alloy round head screw with a nominal length "L" of $\frac{1}{2}$ " is therefore A40/B16.

Brown Brothers Engineering Ltd

B.S. A33, A37, A41, A45 B.A. COUNTERSUNK HEAD SCREWS

Replacing : AGS 249 AGS 968 AGS 248
(MILD STEEL) (STAINLESS STEEL) (BRASS)

Material:

A33 MILD STEEL (Cadmium) A37 STAINLESS STEEL (Self)
A41 ALUMINIUM ALLOY (Anodised) A45 BRASS (Electro-tinned)

ITEM	SIZE	A		B
		MAX.	MIN.	NOMINAL
C	2 BA	IN. 0.319	IN. 0.309	IN. 0.077
B	4 BA	0.252	0.242	0.065
A	6 BA	0.194	0.184	0.051
Z	8 BA	0.157	0.147	0.043
Y	10 BA	0.112	0.107	0.030
X	12 BA	0.095	0.090	0.028

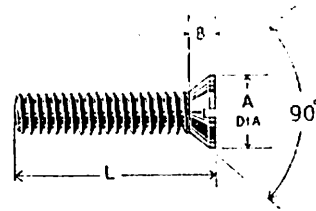

METHOD OF ORDERING

The part reference number consists of the item letter followed by the item number which represents the nominal length "L" in $\frac{1}{32}$ of an inch.

The complete part number for a 4 BA aluminium alloy countersunk head screw with a nominal length "L" of $\frac{1}{2}$ " is therefore A41/B16.

B.S. A34, A38, A42, A46 B.A. RAISED COUNTERSUNK HEAD SCREWS

Material:

A34 MILD STEEL (Cadmium) A38 STAINLESS STEEL (Self)
A42 ALUMINIUM ALLOY (Anodised) A46 BRASS (Electro-tinned)

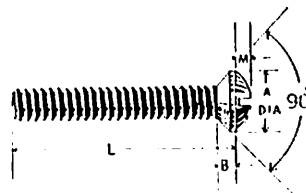

ITEM	SIZE	A		B	M
		MAX.	MIN.	NOMINAL	APPROXIMATE
C	2 BA	IN. 0.319	IN. 0.309	IN. 0.077	IN. 0.036
B	4 BA	0.252	0.242	0.065	0.029
A	6 BA	0.194	0.184	0.051	0.023
Z	8 BA	0.157	0.147	0.043	0.019
Y	10 BA	0.112	0.107	0.030	0.013

METHOD OF ORDERING

The part reference number consists of the item letter followed by the item number which represents the nominal length "L" in $\frac{1}{32}$ of an inch.

The complete part number for a 4 BA aluminium alloy raised countersunk head screw with a nominal length "L" of $\frac{1}{2}$ " is therefore A42/B16.

Brown Brothers Engineering Ltd

B.S. A47 to A54

B.A. ORDINARY & THIN NUTS

Material :

A47 Ordinary	}	MILD STEEL (Cadmium)	A51 Ordinary	}	AL. ALLOY (Anodised)
A48 Thin		A52 Thin	A53 Ordinary		BRASS (Electro-tinned)
A49 Ordinary	}	STAINLESS STEEL (Self)	A54 Thin	}	
A50 Thin					

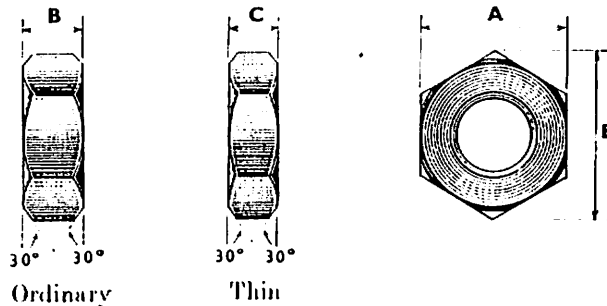

ITEM	SIZE	A		E	B		C	
		MAX.	MIN.	MAX.	MAX.	MIN.	MAX.	MIN.
*C	2 BA	IN. 0.324	IN. 0.319	IN. 0.37	IN. 0.167	IN. 0.157	IN. 0.123	IN. 0.113
*B	4 BA	0.248	0.243	0.29	0.135	0.125	0.094	0.084
*A	6 BA	0.193	0.189	0.22	0.105	0.095	0.073	0.063
Z	8 BA	0.152	0.149	0.18	0.082	0.075	0.058	0.051
Y	10 BA	0.117	0.114	0.14	0.064	0.057	—	—
X	12 BA	0.090	0.088	0.10	0.049	0.044	—	—

METHOD OF ORDERING

The part number consists of the specification number followed by the item letter. The part number for a 4 BA aluminium alloy ordinary nut is therefore A51/B.

* 6, 4 and 2 BA nuts in mild steel should be ordered to BS 2A27 Medium Tensile Steel.

B.S. A55, A56

GRUB SCREWS

Material :

A55 FREE-CUTTING STEEL (Cadmium)
A56 STAINLESS STEEL (Self)

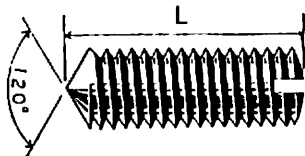

Item	A	B	C	E
Size	6 BA	4 BA	2 BA	1/4" BSF

METHOD OF ORDERING

The part reference number consists of the item letter followed by the item number which represents the length "L" in $\frac{1}{16}$ of an inch. The complete part number for a 2 BA grub screw in free-cutting steel with a length of $\frac{5}{8}$ " is therefore A55/C10.

**CLOSE TOLERANCE
HIGH TENSILE STEEL SHEAR BOLTS**

(Head and Thread: CADMIUM. Shank and Underside of Head: SELF WITH
TEMPORARY RUST PREVENTATIVE)

BSF—B.S. 2A57 UNIFIED—B.S. 2A109

NOMINAL SIZE	1/2" BSF or 1/2" UNF		3/8" BSF or 3/8" UNF		1" BSF or 1" UNF		7/8" BSF or 7/8" UNF	
	MIN.	MAX.	MIN.	MAX.	MIN.	MAX.	MIN.	MAX.
PLAIN SHANK DIAMETER—IN.	0.21925	0.21975	0.31175	0.31225	0.37425	0.37475	0.43675	0.43725
NOMINAL SIZE	1/2" BSF or 1/2" UNF		3/8" BSF or 3/8" UNF		1" BSF or 1" UNF		1" BSF or 1" UNF	
	MIN.	MAX.	MIN.	MAX.	MIN.	MAX.	MIN.	MAX.
PLAIN SHANK DIAMETER IN.	0.19925	0.19975	0.56175	0.56225	0.62425	0.62475	0.74925	0.74975

(For other dimensions and method of ordering, see pages 7, 8 and 9)

**HIGH TENSILE STEEL NUTS FOR SHEAR BOLTS
BSF—B.S. 2A58 UNIFIED—B.S. 2A110**

(CADMIUM)

THIN AND SLOTTED

(For principal dimensions, see page 4)

NOMINAL SIZE	PART NUMBERS		NOMINAL SIZE	PART NUMBERS	
	THIN	SLOTTED		THIN	SLOTTED
*1/2" BSF or 1/2" UNF	ET	ES	1/2" BSF or 1/2" UNF	NT	NS
3/8" BSF or 3/8" UNF	GT	GS	3/8" BSF or 3/8" UNF	PT	PS
1" BSF or 1" UNF	JT	JS	1" BSF or 1" UNF	QT	QS
1 1/8" BSF or 1 1/8" UNF	LT	LS	1 1/8" BSF or 1 1/8" UNF	ST	SS

* 1/2" BSF thin nuts should be ordered as 2A27/ET.

METHOD OF ORDERING

The specification number is suffixed by the part number, e.g. :—

A 3/8" BSF thin nut would be 2A58/GT.

A 3/8" UNF slotted nut would be 2A110/JS.

Brown Brothers Engineering Ltd

**CLOSE TOLERANCE
HIGH TENSILE STEEL BOLTS**

(CADMIUM PLATED ALL OVER)

BA & BSF—B.S. 2A59 UNIFIED—B.S. 3A111

NOMINAL SIZE	2 BA		No. 10-32 UNF		1" BSF or 1" UNF		1 1/2" BSF or 1 1/2" UNF	
	MIN.	MAX.	MIN.	MAX.	MIN.	MAX.	MIN.	MAX.
PLAIN SHANK DIA.—IN. (AFTER PLATING)	0.18675	0.18725	0.18905	0.18955	0.21925	0.21975	0.31175	0.31225
NOMINAL SIZE	1" BSF or 1" UNF		1 1/2" BSF or 1 1/2" UNF		1" BSF or 1" UNF			
PLAIN SHANK DIA.—IN. (AFTER PLATING)	0.37425	0.37475	0.43075	0.43125	0.49925	0.49975		

(For other dimensions and method of ordering, see pages 5, 6, 8 and 9)

**CLOSE TOLERANCE
HIGH TENSILE STEEL SHEAR BOLTS**

(CADMIUM PLATED ALL OVER)

BSF—B.S. 2A60 UNIFIED—B.S. 2A112

NOMINAL SIZE	1" BSF or 1" UNF		1 1/2" BSF or 1 1/2" UNF		1" BSF or 1" UNF		1 1/2" BSF or 1 1/2" UNF	
	MIN.	MAX.	MIN.	MAX.	MIN.	MAX.	MIN.	MAX.
PLAIN SHANK DIAMETER—IN. (AFTER PLATING)	0.24925	0.24975	0.31175	0.31225	0.37425	0.37475	0.43075	0.43125
NOMINAL SIZE	1" BSF or 1" UNF		1 1/2" BSF or 1 1/2" UNF		1" BSF or 1" UNF		1 1/2" BSF or 1 1/2" UNF	
PLAIN SHANK DIAMETER—IN. (AFTER PLATING)	0.49925	0.49975	0.56175	0.56225	0.62125	0.62175	0.74925	0.74975

(For other dimensions and method of ordering, see pages 7, 8 and 9)

ALUMINIUM ALLOY BOLTS

(ANODISED AND DYED GREEN)

BA & BSF—B.S. 2A61

(Replacing A28 and A17)

Normally supplied in sizes up to 1/2" BSF only

(For principal dimensions and method of ordering, see pages 5, 8 and 9)

B.S. 3A102 UNIFIED HIGH TENSILE STEEL BOLTS

(See page 10)

Brown Brothers Engineering Ltd

B.S. 3A103 UNIFIED MEDIUM TENSILE STEEL NUTS

(See page 11)

B.S. 3A104 UNIFIED HIGH TENSILE STAINLESS STEEL BOLTS

(See page 11)

B.S. 3A105 UNIFIED HIGH TENSILE STAINLESS STEEL NUTS

(See page 10)

B.S. A106 UNIFIED ALUMINIUM ALLOY BOLTS

(See page 12)

(Replaced by 3A169)

B.S. 3A107 UNIFIED ALUMINIUM ALLOY NUTS

(See page 12)

**B.S. 3A108 UNIFIED CLOSE TOLERANCE
HIGH TENSILE STEEL BOLTS**

(UNPLATED SHANK)

(See page 12)

**B.S. 2A109 UNIFIED CLOSE TOLERANCE
HIGH TENSILE STEEL SHEAR BOLTS**

(UNPLATED SHANK)

(See page 16)

**B.S. 2A110 UNIFIED HIGH TENSILE STEEL NUTS
FOR SHEAR BOLTS**

(See page 16)

**B.S. 3A111 UNIFIED CLOSE TOLERANCE
HIGH TENSILE STEEL BOLTS**

(CADMIUM PLATED SHANK)

(See page 17)

**B.S. 2A112 UNIFIED CLOSE TOLERANCE
HIGH TENSILE STEEL SHEAR BOLTS**

(CADMIUM PLATED SHANK)

(See page 17)

Brown Brothers Engineering Ltd

B.S. 3A113, 3A114 & A115

UNIFIED MUSHROOM HEAD BOLTS

Material:

3A113 HIGH TENSILE STEEL (CADMIUM)

3A114 STAINLESS STEEL (SELF)

A115 ALUMINIUM ALLOY (ANODISED AND DYED BLUE)

(A115 replaced by 3A170)

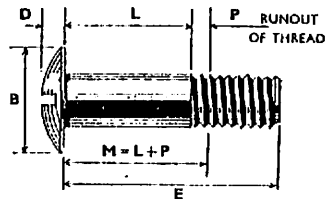

L = PLAIN LENGTH
M = CLAMPING LENGTH

ITEM	NOMINAL SIZE	B Dia.		P MAX. 2 × PITCH	E		D	
		MIN.	MAX.		MIN.	MAX.		
B	No. 6-32 UNC	IN. 0.303	IN. 0.316	IN. 0.063	IN. M + 0.337	IN. 0.086		
C	No. 8-32 UNC	0.364	0.378	0.063	M + 0.387	0.102		
D	No. 10-32 UNF	0.425	0.441	0.063	M + 0.437	0.118		
E	$\frac{1}{4}$ " UNF	0.546	0.565	0.071	M + 0.529	0.150		
G	$\frac{5}{16}$ " UNF	0.666	0.690	0.083	M + 0.567	0.183		

METHOD OF ORDERING

Mushroom head bolts are ordered by the British Standard Number, followed by a number indicating the nominal length of plain shank "L" in tenths of an inch followed by the item letter indicating the nominal size required, e.g. the part number of a $\frac{1}{4}$ " UNF mushroom head bolt in stainless steel, with a plain length 0.5", would be 2A114/5E.

Brown Brothers Engineering Ltd

B.S. 3A116, 3A117 & A118 UNIFIED PAN HEAD BOLTS

Material:

3A116 HIGH TENSILE STEEL
(CADMIUM)
3A117 STAINLESS STEEL (SELF)
A118 ALUMINIUM ALLOY
(ANODISED AND DYED BLUE)

(A118 replaced by 3A171)

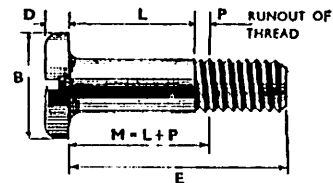

L = PLAIN LENGTH
M = CLAMPING LENGTH

ITEM	NOMINAL SIZE	B DIA.		P' MAX. 2 × PITCH	E		D	
		MIN.	MAX.		MIN.	MAX.	MIN.	MAX.
A	No. 4-40 UNC	IN. 0.184	IN. 0.194	IN. 0.050	IN. M + 0.350	IN. 0.068		
B	No. 6-32 UNC	0.242	0.252	0.063	M + 0.337	0.082		
C	No. 8-32 UNC	0.273	0.283	0.063	M + 0.387	0.096		
D	No. 10-32 UNF	0.309	0.319	0.063	M + 0.437	0.110		
E	½" UNF	0.420	0.440	0.071	M + 0.529	0.144		
G	⅝" UNF	0.527	0.547	0.083	M + 0.567	0.178		

METHOD OF ORDERING

Pan head bolts are ordered by the British Standard Number, followed by a number indicating the nominal length of plain shank "L" in tenths of an inch followed by the item letter indicating the nominal size required, e.g. the part number of a ½" UNF Pan head bolt in stainless steel, with a plain length of 0.5", would be 2A117/5E.

B.S. A119, A120 & A121 UNIFIED 90° COUNTERSUNK HEAD BOLTS

A119 REPLACED BY 2A173

A120 REPLACED BY 2A174

A121 REPLACED BY 2A175

Brown Brothers Engineering Ltd

B.S. A.122—A.124 UNIFIED CLINCH NUTS

Material: A122 STEEL (CADMIUM)

A123 BRASS OR BRONZE (ELECTRO-TINNED)

A124 ALUMINIUM ALLOY (ANODISED)

(For details see "Oddie Nuts & Anchorages", page 261)

B.S. 2A125—2A168 UNIFIED STIFFNUTS

(For details see "Oddie Nuts & Anchorages", page 262)

B.S. 3A169 UNIFIED ALUMINIUM ALLOY BOLTS

(ANODISED AND DYED GREEN)

(Replacing A106)

(For principal dimensions and method of ordering, see pages 6, 8 and 9)

**B.S. 3A170 UNIFIED ALUMINIUM ALLOY
MUSHROOM HEAD BOLTS**

(ANODISED AND DYED GREEN)

(Replacing A115)

All dimensions as for A115

**B.S. 3A171 UNIFIED ALUMINIUM ALLOY
PAN HEAD BOLTS**

(ANODISED AND DYED GREEN)

(Replacing A118)

All dimensions as for A118

**B.S. A172 UNIFIED 90° ALUMINIUM ALLOY
COUNTERSUNK HEAD BOLTS**

(ANODISED AND DYED GREEN)

Replaced by 2A175

Brown Brothers Engineering Ltd

B.S. 2A173, 2A174 & 2A175

UNIFIED 100° COUNTERSUNK BOLTS (Flushness Toleranced Head)

Material:

2A173 HIGH TENSILE STEEL (CADMIUM)

2A174 STAINLESS STEEL (SELF)

2A175 ALUMINIUM ALLOY (ANODISED AND DYED GREEN)

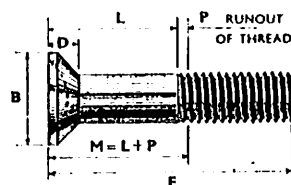

L = PLAIN LENGTH
M = CLAMPING LENGTH

ITEM	NOMINAL SIZE	P MAX. 2 × PITCH	E MIN.	B MIN.	D REF. ONLY
C	No. 8-32 UNC	IN. 0.063	M + 0.387	0.287	0.068
D	No. 10-32 UNF	0.063	M + 0.437	0.337	0.080
E	1" UNF	0.071	M + 0.529	0.452	0.106
G	5/16" UNF	0.083	M + 0.567	0.572	0.133
J	3/8" UNF	0.083	M + 0.667	0.692	0.159
L	7/16" UNF	0.100	M + 0.750	0.812	0.186
N	1/2" UNF	0.100	M + 0.850	0.932	0.213

METHOD OF ORDERING

Bolts to the above specifications are ordered by the British Standard Number, followed by a number indicating the length of the plain shank "L" in tenths of an inch, followed by the item letter indicating the nominal size, e.g. the part No. of a 5/16" UNF stainless steel bolt, 1" long, is 2A174/10G.

B.S. 2A180 & 2A181 UNIFIED STIFFNUTS 2A186 & 2A187 2A192 & 2A193 2A200 & 2A201

(For details see "Oddie Nuts and Anchorages", page 262)

Brown Brothers Engineering Ltd

BS. 2A204, 2A206, 2A208 & A220 UNIFIED 100° COUNTERSUNK HEAD SCREW

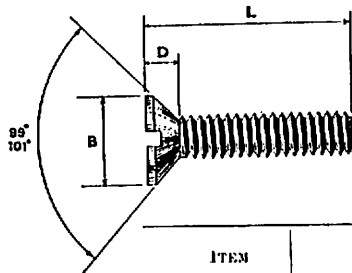

Material:

2A204 MILD STEEL (CADMIUM)
 2A206 STAINLESS STEEL (SELF)
 2S208 ALUMINIUM ALLOY (ANODISED AND
 DYED GREEN)
 A220 BRASS (ELECTRO TINNED)

ITEM	SIZE	B DIA.		D
		MAX.	MIN.	MAX.
Y	No. 0 × 80 UNF	IN. 0.110	IN. 0.102	IN. 0.026
Z	No. 2 × 64 UNF	0.158	0.148	0.038
A	No. 4 × 40 UNC	0.206	0.191	0.049
B	No. 6 × 32 UNC	0.255	0.238	0.051
C	No. 8 × 32 UNC	0.303	0.285	0.073
D	No. 10 × 32 UNF	0.351	0.333	0.084

METHOD OF ORDERING

Screws to the above specifications are ordered by the British Standard Number followed by the letter representing the thread size, followed by a numeral representing the nominal length "L" in $\frac{1}{32}$ of an inch, e.g. the part number of a countersunk head screw in aluminium alloy $\frac{1}{2}$ " long with a No. 6 × 32 UNC thread would be 2A208/B16.

B.S. A205, A207, A209 UNIFIED PAN HEAD SCREWS

(Superseded by A217, A218, A219)

Material:

A205 MILD STEEL (CADMIUM)
 A207 STAINLESS STEEL (SELF)
 A209 ALUMINIUM ALLOY (ANODISED AND DYED GREEN)

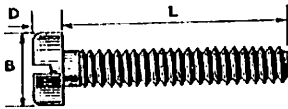

ITEM	SIZE	B DIA.		D	
		MAX.	MIN.	MAX.	MIN.
A	No. 4-40 UNC	IN. 0.194	IN. 0.184	IN. 0.068	IN. 0.058
B	No. 6-32 UNC	0.252	0.242	0.082	0.072
C	No. 8-32 UNC	0.283	0.273	0.096	0.085
D	No. 10-32 UNF	0.319	0.309	0.110	0.099

METHOD OF ORDERING

Screws to the above specifications are ordered by the British Standard Number followed by the letter indicating the thread size, followed by a numeral(s) representing the nominal length "L" in $\frac{1}{32}$ of an inch, e.g. the part number of a pan head screw in aluminium alloy $\frac{1}{2}$ " long, with a No. 6-32 UNC thread, would be A209/B16.

Brown Brothers Engineering Ltd

B.S. 2A210 UNIFIED ORDINARY & THIN NUTS (Brass)

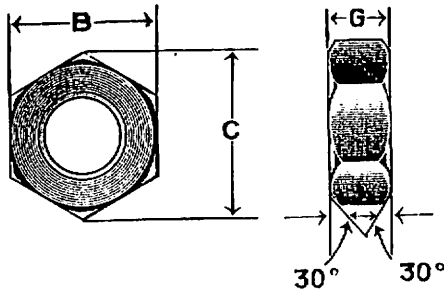

Material: BRASS
Finish: (ELECTRO-TINNED)

THREAD SIZE	PART REF.				B		C	G			
	ORDINARY		THIN		MIN.	MAX.	MAX.	ORDINARY		THIN	
	R.H.	L.H.	R.H.	L.H.				MIN.	MAX.	MIN.	MAX.
No. 4-40 U.N.C.	AP	APL	AT	ATL	0.183"	0.188"	0.217"	0.095"	0.105"	0.063"	0.073"
No. 6-32 U.N.C.	BP	BPL	BT	BTL	0.245"	0.250"	0.289"	0.115"	0.125"	0.079"	0.089"
No. 8-32 U.N.C.	CP	CPL	CT	CTL	0.307"	0.312"	0.381"	0.145"	0.155"	0.103"	0.113"
No. 10-32 U.N.F.	DP	DPL	DT	DTL	0.339"	0.344"	0.397"	0.157"	0.167"	0.113"	0.123"

METHOD OF ORDERING

The part number consists of the specification number followed by the Item letter. The part number for a No. 6 × 32 U.N.C. brass ordinary nut is therefore 2A210/BP.

B.S. A211 UNIFIED 100° COUNTERSUNK BOLTS. WITH CRUCIFORM RECESSES

Material: HIGH TENSILE STEEL (CADMIUM)
Identical to 2A173 except driver slot

B.S. A217, A218, A219, & A221 UNIFIED PAN HEAD SCREWS

Material: A217—MILD STEEL (CADMIUM). A218—STAINLESS STEEL (SELF).
A219—ALUMINIUM ALLOY (ANODISED AND DYED GREEN). A221—BRASS (ELECTRO-TINNED)

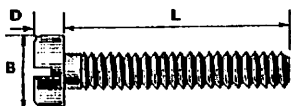

ITEM	SIZE	B DIA.		D	
		MAX.	MIN.	MAX.	MIN.
Y	No. 0 × 80 UNF	0.116"	0.104"	0.039"	0.031"
Z	No. 2 × 64 UNF	0.187"	0.155"	0.053"	0.045"
A	No. 4 × 40 UNC	0.219"	0.205"	0.068"	0.058"
B	No. 6 × 32 UNC	0.270"	0.250"	0.082"	0.072"
C	No. 8 × 32 UNC	0.322"	0.306"	0.096"	0.085"
D	No. 10 × 32 UNF	0.373"	0.357"	0.110"	0.099"

METHOD OF ORDERING

Screws to the above specifications are ordered by the British Standard Number followed by the letter representing the thread size followed by a numeral representing the nominal length "L" in 1/32 of an inch, e.g. the part number of a pan head screw in aluminium alloy 1/2" long with No. 6 × 32 U.N.C. thread would be A219/B16.

Brown Brothers Engineering Ltd

B.S. A222, A223, A224 & A225

UNIFIED ORDINARY & THIN NUTS

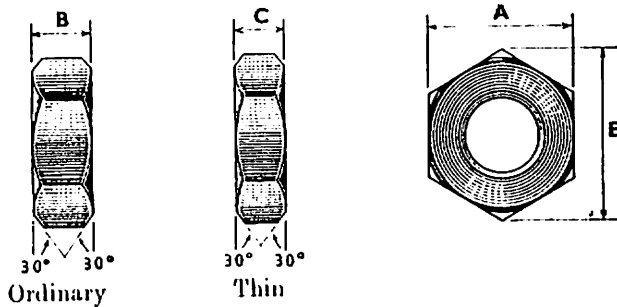

A222 Ordinary	}	MILD STEEL (CADMIUM)
A223 Thin		
A224 Ordinary	}	BRASS (Electro-tinned)
A225 Thin		

ITEM	SIZE	A		E	B		C	
		MAX.	MIN.	MAX.	MAX.	MIN.	MAX.	MIN.
Y	No. 0 × 80 UNF	0.125"	0.120"	0.144"	0.055"	0.050"	—	—
Z	No. 2 × 64 UNF	0.156"	0.151"	0.180"	0.082"	0.075"	0.058"	0.051"

METHOD OF ORDERING

The part number consists of the specification number followed by the item number. The part number for a No. 2 × 64 U.N.F. brass ordinary nut is therefore A224/Z.
No. 0 × 80 U.N.F. available as ordinary type only.

B.S. A226

HEXAGON HEAD BOLTS UNIFIED SHORT THREAD—CLASS 3A

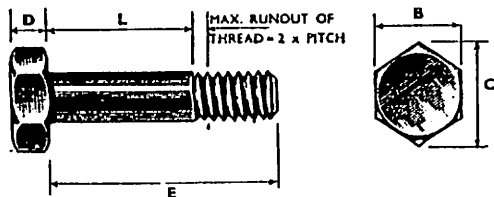

Material:
HIGH TENSILE STEEL
(CADMIUM)

ITEM	NOMINAL SIZE	B		C	E	D
		MIN.	MAX.	MAX.	NOM.	MAX.
A	No. 4 × 40 UNC	0.183"	0.188"	0.217"	L + 0.308"	0.070"
B	No. 6 × 32 UNC	0.245"	0.250"	0.289"	L + 0.357"	0.085"
C	No. 8 × 32 UNC	0.307"	0.312"	0.361"	L + 0.404"	0.100"
D	No. 10 × 32 UNF	0.339"	0.344"	0.397"	L + 0.404"	0.115"

METHOD OF ORDERING

Bolts to the above specification are ordered by the British Standard Number followed by the letter representing the thread size, followed by a numeral representing the nominal length "L" in 16ths of an inch, e.g. the part number of a hexagon head bolt 7/16" long with a No. 6 × 32 U.N.C. thread would be A226/B7.

Brown Brothers Engineering Ltd

B.S. A227

PAN HEAD BOLTS

UNIFIED SHORT THREAD—CLASS 3A

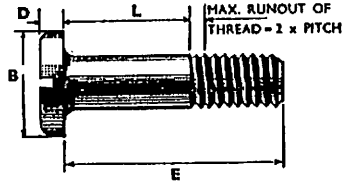

Material:
HIGH TENSILE STEEL
(CADMIUM)

ITEM	NOMINAL SIZE	B		E	D
		MIN.	MAX.	NOM.	MAX.
A	No. 4 × 40 UNC	0.205"	0.219"	L + 0.308"	0.068"
B	No. 6 × 32 UNC	0.250"	0.270"	L + 0.357"	0.082"
C	No. 8 × 32 UNC	0.300"	0.322"	L + 0.404"	0.096"
D	No. 10 × 32 UNF	0.357"	0.373"	L + 0.404"	0.110"

METHOD OF ORDERING

Bolts to the above specification are ordered by the British Standard Number followed by the letter representing the thread size, followed by a numeral representing the nominal length "L" in $\frac{1}{16}$ of an inch, e.g. the part number of a pan head bolt $\frac{7}{16}$ " long with a No. 6 × 32 U.N.C. thread would be A227/B7.

B.S. A228

DOUBLE HEXAGON BOLTS

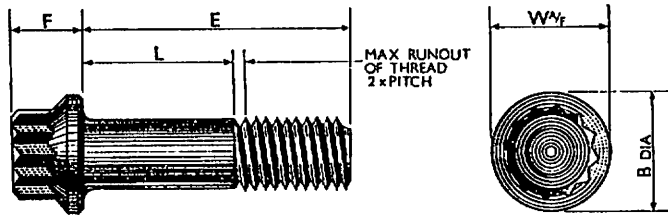

Material:
HIGH TENSILE STEEL
(CADMIUM)

ITEM	NOMINAL SIZE	W		B	E	F
		MIN.	MAX.	NOM.	NOM.	NOM.
E	$\frac{1}{8}$ " UNJF	0.307"	0.313"	0.433"	L + 0.512"	0.300"
G	$\frac{3}{16}$ " UNJF	0.370"	0.376"	0.520"	L + 0.590"	0.348"
J	$\frac{1}{4}$ " UNJF	0.432"	0.439"	0.644"	L + 0.645"	0.388"
L	$\frac{5}{16}$ " UNJF	0.495"	0.502"	0.745"	L + 0.741"	0.435"
N	$\frac{3}{8}$ " UNJF	0.557"	0.564"	0.823"	L + 0.788"	0.504"
P	$\frac{7}{16}$ " UNJF	0.620"	0.627"	0.933"	L + 0.872"	0.557"
Q	$\frac{1}{2}$ " UNJF	0.683"	0.690"	1.045"	L + 0.919"	0.618"
S	$\frac{5}{8}$ " UNJF	0.806"	0.814"	1.225"	L + 1.056"	0.711"
U	$\frac{3}{4}$ " UNJF	0.932"	0.940"	1.433"	L + 1.264"	0.808"
W	1" UNJF	1.056"	1.064"	1.620"	L + 1.490"	0.923"

METHOD OF ORDERING

Bolts to the above specification are ordered by the British Standard Number followed by the letter representing the thread size, followed by a numeral representing the nominal length "L" in $\frac{1}{16}$ of an inch, e.g. the part number of a double hexagon head bolt .625" long with a $\frac{3}{8}$ " U.N.J.F. thread would be A228/J10.

Brown Brothers Engineering Ltd
HEXAGON HEAD BOLT

B.S. A229

Material: HIGH TENSILE STEEL
(CADMIUM)

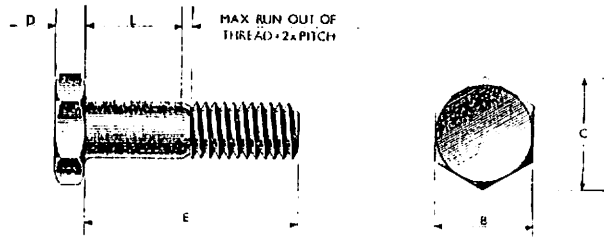

ITEM	NOMINAL SIZE	B		C	D	E
		MIN.	MAX.	MAX.	NOM.	MAX.
D	No. 10 × 32 UNJF	0.367"	0.376"	0.434"	L ± 0.406"	0.125"
E	1/4" UNJF	0.430"	0.439"	0.507"	L ± 0.468"	0.140"
G	5/16" UNJF	0.492"	0.502"	0.580"	L ± 0.531"	0.171"
J	3/8" UNJF	0.553"	0.564"	0.651"	L ± 0.641"	0.203"
L	7/16" UNJF	0.679"	0.690"	0.797"	L ± 0.656"	0.234"
N	1/2" UNJF	0.741"	0.752"	0.868"	L ± 0.782"	0.265"

METHOD OF ORDERING

Bolts to the above specification are ordered by the British Standard Number followed by the letter representing the thread size, followed by a numeral representing the nominal length "L" in 1/16" of an inch, e.g. the part number of a hexagon head bolt .625" long with a 3/8" UNJF thread would be A229/J10.

B.S. A230 & A232 100° COUNTERSUNK HEAD BOLTS

A230 With HI-TORQUE RECESSES
A232 With TORQ-SET RECESSES

Material: HIGH TENSILE STEEL
(CADMIUM)

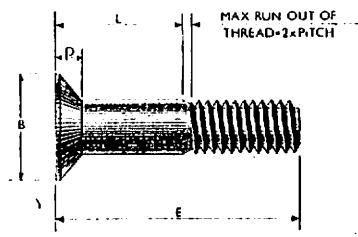

ITEM	NOMINAL SIZE	B MIN.	E NOM.	D REF.
D	No. 10 × 32 UNJF	0.328"	L ± 0.406"	0.080"
E	1/4" UNJF	0.449"	L ± 0.468"	0.106"
G	5/16" UNJF	0.577"	L ± 0.531"	0.133"
J	3/8" UNJF	0.704"	L ± 0.641"	0.160"
L	7/16" UNJF	0.832"	L ± 0.656"	0.188"
N	1/2" UNJF	0.959"	L ± 0.782"	0.215"

METHOD OF ORDERING

Bolts to the above specifications are ordered by the British Standard Number followed by the letter representing the thread size followed by a numeral representing the nominal length "L" in 1/16" of an inch, e.g. the part number of a 100° Countersunk Head Bolt with Torq-Set Recess, .625" long with a 3/8" UNJF thread would be A232/J10.

B.S. G154 SCREWS WITH CAPTIVE WASHERS

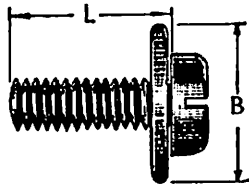

(Replacing AGS 1753 and 1754)

Material: MILD STEEL (CADMIUM).

LENGTH "L"	SCREW		WASHER	
	PART NUMBER		PART NUMBER	DIA. "B" IN.
	6 BA	4 BA		
1/8"	A6	—	1	0.20
1/4"	A8	B8	2	0.23
5/16"	A10	B10	3	0.25
3/8"	A12	B12	4	0.28
7/8"	A14	B14	5	0.33
1/2"	A16	B16	6	0.47
3/8"	—	B20	7	0.53

METHOD OF ORDERING

Screws to the above specification are ordered by the British Standard Number followed by the part number of the screw and the part number of the washer required, e.g. the complete part number of a 4BA screw 1/2" long, with a 0.25" dia. washer, would be G154/B16/3.

B.S. G203

**SCREWS WITH CAPTIVE
FACING & LOCKING WASHERS**

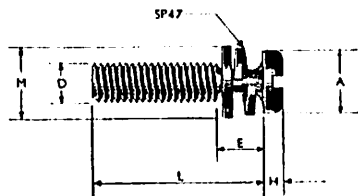

Material:

SCREW & PLAIN WASHER—STAINLESS
STEEL (SELF)

LOCKING WASHER—STEEL (CADMIUM)

ITEM	D THREAD	A	E	H	L	M
A	4 x 40 UNC	0.210"	0.120"	0.063"	0.550"	0.235"
B	6 x 32 UNC	0.260"	0.128"	0.077"	0.550"	0.315"
D	10 x 32 UNF	0.365"	0.164"	0.105"	0.550"	0.405"

Brown Brothers Engineering Ltd

B.S. 2SPI STANDARD SHACKLES

Material: STEEL STAMPING
(CADMIUM)

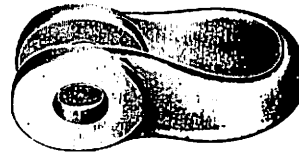

PART No.	DIAMETER OF PIN HOLE	WIDTH BETWEEN JAWS	WIDTH OVER JAWS	PIN SP4 No.	MINIMUM TENSILE STRENGTH	SUITABLE FOR USE WITH CABLE
	IN.	IN.	IN.			LBS.
690A	$\frac{1}{2}$	0.10	0.23	A2	1120	10
690B	$\frac{3}{8}$	0.15	0.34	B4	2240	20
690C	$\frac{1}{4}$	0.20	0.45	D6	3920	35
690D	$\frac{5}{16}$	0.20	0.48	E7	5040	45
690E	$\frac{11}{16}$	0.25	0.55	G8	6720	60
690F	$\frac{3}{4}$	0.30	0.64	J10	8960	80

B.S. 3SP3 FORK JOINTS (Low Tensile)

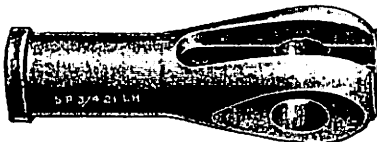

Fork with Collar omitted indicates Stainless Steel.

Material :
MILD STEEL
(CADMIUM)
or
STAINLESS STEEL

Alternative design when Cold Headed



Fork without raised ring indicates Stainless Steel.

PART No.		THREADS	DIAMETER OF PIN HOLE	WIDTH OVER JAWS	WIDTH BETWEEN JAWS	SLOT DEPTH FROM PIN CENTRE	PIN SP4	MINIMUM TENSILE STRENGTH
R.H.	L.H.		IN.	IN.	IN.	IN.		
412	412L	4 BA	$\frac{3}{8}$	0.26	0.10	0.35	A2	LBS. 1,155
413	413L	2 BA	$\frac{1}{2}$	0.33	0.15	0.40	B3	2,090
414	414L	$\frac{1}{4}$ " BSF	$\frac{1}{2}$	0.48	0.20	0.50	D6	3,795
416	416L	$\frac{3}{8}$ " BSF	$\frac{11}{16}$	0.68	0.25	0.70	G10	6,270
418	418L	$\frac{1}{2}$ " BSF	$\frac{13}{16}$	0.78	0.30	0.80	J12	9,350
420	420L	$\frac{5}{8}$ " BSF	$\frac{15}{16}$	0.83	0.36	1.0	L13	12,980
422	422L	$\frac{3}{4}$ " BSF	$\frac{17}{16}$	0.98	0.40	1.17	N16	17,050

When ordering: The letter "Y" must precede Part No. for Non-Stainless Steel, e.g. 3SP3 Y,414L.
The letter "Z" must precede Part No. for Stainless Steel, e.g. 3SP3 Z,414L.
For High Tensile Fork Joints see B.S. 2SP7

Brown Brothers Engineering Ltd

B.S. 5SP4

STEEL PINS

*Pins up to and including size N ($\frac{3}{32}$ " dia.)
may be Cold Headed*

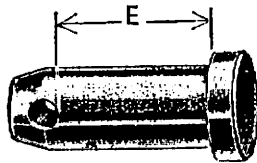

**Material : H.T. STEEL
(CADMIUM)
or STAINLESS STEEL**

WHEN ORDERING :

THE LETTER "Y" MUST PRECEDE PART NO. FOR NON-STAINLESS STEEL, *e.g.* 5SP4 Y,C12.
THE LETTER "Z" MUST PRECEDE PART NO. FOR STAINLESS STEEL, *e.g.* 5SP4 Z,C12.

LENGTH E INS.	DIAMETER								
	$\frac{1}{8}$ "	$\frac{3}{16}$ "	$\frac{1}{4}$ "	$\frac{5}{16}$ "	$\frac{3}{8}$ "	$\frac{7}{16}$ "	$\frac{1}{2}$ "	$\frac{5}{8}$ "	$\frac{3}{4}$ "
	PART NUMBERS								
0.25	A1	B1	C1	D1	E1	F1	G1	H1	J1
0.30	A2	B2	C2	D2	E2	F2	G2	H2	J2
0.35	A3	B3	C3	D3	E3	F3	G3	H3	J3
0.40	A4	B4	C4	D4	E4	F4	G4	H4	J4
0.45	A5	B5	C5	D5	E5	F5	G5	H5	J5
0.50	A6	B6	C6	D6	E6	F6	G6	H6	J6
0.55	A7	B7	C7	D7	E7	F7	G7	H7	J7
0.60	A8	B8	C8	D8	E8	F8	G8	H8	J8
0.65	A9	B9	C9	D9	E9	F9	G9	H9	J9
0.70	A10	B10	C10	D10	E10	F10	G10	H10	J10
0.75	A11	B11	C11	D11	E11	F11	G11	H11	J11
0.80	A12	B12	C12	D12	E12	F12	G12	H12	J12
0.85	A13	B13	C13	D13	E13	F13	G13	H13	J13
0.90	A14	B14	C14	D14	E14	F14	G14	H14	J14
0.95	A15	B15	C15	D15	E15	F15	G15	H15	J15
1.00	A16	B16	C16	D16	E16	F16	G16	H16	J16
1.1	—	B17	C17	D17	E17	F17	G17	H17	J17
1.2	—	B18	C18	D18	E18	F18	G18	H18	J18
1.3	—	B19	C19	D19	E19	F19	G19	H19	J19
1.4	—	B20	C20	D20	E20	F20	G20	H20	J20
1.5	—	B21	C21	D21	E21	F21	G21	H21	J21
1.6	—	B22	C22	D22	E22	F22	G22	H22	J22
1.7	—	B23	C23	D23	E23	F23	G23	H23	J23
1.8	—	B24	C24	D24	E24	F24	G24	H24	J24
1.9	—	B25	C25	D25	E25	F25	G25	H25	J25
2.0	—	B26	C26	D26	E26	F26	G26	H26	J26
2.2	—	—	—	D27	E27	F27	G27	H27	J27
2.4	—	—	—	D28	E28	F28	G28	H28	J28
2.6	—	—	—	D29	E29	F29	G29	H29	J29
2.8	—	—	—	D30	E30	F30	G30	H30	J30
3.0	—	—	—	D31	E31	F31	G31	H31	J31
3.2	—	—	—	—	—	—	—	H32	J32
3.4	—	—	—	—	—	—	—	H33	J33

Brown Brothers Engineering Ltd

B.S. 5SP4

STEEL PINS—(cont.)

Pins up to and including size N (1 1/2" dia.) may be Cold Headed

**Material : H.T. STEEL
(CADMIUM)
or STAINLESS STEEL**

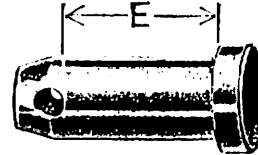

WHEN ORDERING :

THE LETTER "Y" MUST PRECEDE PART NO. FOR NON-STAINLESS STEEL, e.g. 5SP4 Y,M16.
THE LETTER "Z" MUST PRECEDE PART NO. FOR STAINLESS STEEL, e.g. 5SP4 Z,M16.

LENGTH E IN.	DIAMETER								
	1/2"	3/4"	1"	1 1/4"	1 1/2"	1 3/4"	2"	2 1/4"	2 1/2"
	PART NUMBERS								
0-25	K1	L1	M1	N1	—	—	—	—	—
0-30	K2	L2	M2	N2	P2	—	—	—	—
0-35	K3	L3	M3	N3	P3	Q3	—	—	—
0-40	K4	L4	M4	N4	P4	Q4	—	—	—
0-45	K5	L5	M5	N5	P5	Q5	R5	—	—
0-50	K6	L6	M6	N6	P6	Q6	R6	—	—
0-55	K7	L7	M7	N7	P7	Q7	R7	S7	—
0-60	K8	L8	M8	N8	P8	Q8	R8	S8	T8
0-65	K9	L9	M9	N9	P9	Q9	R9	S9	T9
0-70	K10	L10	M10	N10	P10	Q10	R10	S10	T10
0-75	K11	L11	M11	N11	P11	Q11	R11	S11	T11
0-80	K12	L12	M12	N12	P12	Q12	R12	S12	T12
0-85	K13	L13	M13	N13	P13	Q13	R13	S13	T13
0-90	K14	L14	M14	N14	P14	Q14	R14	S14	T14
0-95	K15	L15	M15	N15	P15	Q15	R15	S15	T15
1-00	K16	L16	M16	N16	P16	Q16	R16	S16	T16
1-1	K17	L17	M17	N17	P17	Q17	R17	S17	T17
1-2	K18	L18	M18	N18	P18	Q18	R18	S18	T18
1-3	K19	L19	M19	N19	P19	Q19	R19	S19	T19
1-4	K20	L20	M20	N20	P20	Q20	R20	S20	T20
1-5	K21	L21	M21	N21	P21	Q21	R21	S21	T21
1-6	K22	L22	M22	N22	P22	Q22	R22	S22	T22
1-7	K23	L23	M23	N23	P23	Q23	R23	S23	T23
1-8	K24	L24	M24	N24	P24	Q24	R24	S24	T24
1-9	K25	L25	M25	N25	P25	Q25	R25	S25	T25
2-0	K26	L26	M26	N26	P26	Q26	R26	S26	T26
2-2	K27	L27	M27	N27	P27	Q27	R27	S27	T27
2-4	K28	L28	M28	N28	P28	Q28	R28	S28	T28
2-6	K29	L29	M29	N29	P29	Q29	R29	S29	T29
2-8	K30	L30	M30	N30	P30	Q30	R30	S30	T30
3-0	K31	L31	M31	N31	P31	Q31	R31	S31	T31
3-2	K32	L32	M32	N32	P32	Q32	R32	S32	T32
3-4	K33	L33	M33	N33	P33	Q33	R33	S33	T33

Brown Brothers Engineering Ltd

B.S. 5SP4

STEEL PINS—(cont.)

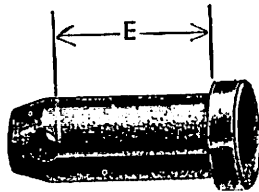

Material : H.T. STEEL

(CADMIUM)

or STAINLESS STEEL

WHEN ORDERING :

THE LETTER " Y " MUST PRECEDE PART NO. FOR NON-STAINLESS STEEL, *e.g.* 5SP4 Y,V20.
THE LETTER " Z " MUST PRECEDE PART NO. FOR STAINLESS STEEL, *e.g.* 5SP4 Z,X25.

LENGTH E IN.	DIAMETER					
	1"	1 1/8"	1 1/4"	1 1/2"	1"	1 1/8"
	PART NUMBERS					
1-1	U17	V17	W17	X17	Y17	—
1-2	U18	V18	W18	X18	Y18	—
1-3	U19	V19	W19	X19	Y19	—
1-4	U20	V20	W20	X20	Y20	Z20
1-5	U21	V21	W21	X21	Y21	Z21
1-6	U22	V22	W22	X22	Y22	Z22
1-7	U23	V23	W23	X23	Y23	Z23
1-8	U24	V24	W24	X24	Y24	Z24
1-9	U25	V25	W25	X25	Y25	Z25
2-0	U26	V26	W26	X26	Y26	Z26
2-2	U27	V27	W27	X27	Y27	Z27
2-4	U28	V28	W28	X28	Y28	Z28
2-6	U29	V29	W29	X29	Y29	Z29
2-8	U30	V30	W30	X30	Y30	Z30
3-0	U31	V31	W31	X31	Y31	Z31
3-2	U32	V32	W32	X32	Y32	Z32
3-4	U33	V33	W33	X33	Y33	Z33

Brown Brothers Engineering Ltd

B.S. SP6

TURNBUCKLES

Obsolete. Replaced by SP33

Material :
Eyes and Forks, MILD STEEL
Barrels, BRASS
(CADMIUM)

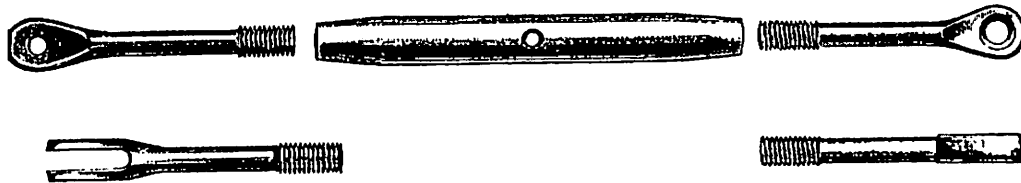

PART No.		TO TAKE WIRE ROPE B.S. W2	MAXI- MUM ADJUST- MENT	SIZE OF THREADS	FORK A			BARREL B		EYE C OR E	
AGS	SP6				DIAM. OF PIN HOLE	WIDTH OVER JAWS	WIDTH BETWEEN JAWS	LENGTH	DIAM. OF BODY	DIAM. OF HOLE	THICK- NESS
		CWT.	IN.		IN.	IN.	IN.	IN.	IN.	IN.	IN.
490	5	5	0.75	4 BA	$\frac{5}{32}$	0.18	0.08	1.7	0.25	$\frac{1}{4}$	0.12
491	10	10	2	2 BA	$\frac{5}{32}$	0.26	0.10	3.2	0.3125	$\frac{1}{4}$	0.17
492	20L	20	2	$\frac{1}{4}$ " BSF	$\frac{3}{16}$	0.33	0.15	3.5	0.4375	$\frac{7}{32}$	0.20
506	20S	20	1	$\frac{1}{4}$ " BSF	$\frac{3}{16}$	0.33	0.15	2.5	0.38	$\frac{7}{32}$	0.20
493	35L	35	2	$\frac{5}{16}$ " BSF	$\frac{1}{4}$	0.45	0.20	3.8	0.50	$\frac{9}{32}$	0.26
507	35S	35	1	$\frac{5}{16}$ " BSF	$\frac{1}{4}$	0.45	0.20	2.8	0.47	$\frac{9}{32}$	0.26
494	45L	45	2	$\frac{3}{8}$ " BSF	$\frac{9}{32}$	0.58	0.20	4.0	0.58	$\frac{5}{16}$	0.32
508	45S	45	1	$\frac{3}{8}$ " BSF	$\frac{9}{32}$	0.58	0.20	3.0	0.58	$\frac{5}{16}$	0.32
495	60	60	2	$\frac{11}{16}$ " BSF	$\frac{11}{32}$	0.68	0.25	4.0	0.58	$\frac{7}{16}$	0.36
496	70	70	2	$\frac{7}{8}$ " BSF	$\frac{11}{16}$	0.73	0.25	4.1	0.60	$\frac{13}{16}$	0.39
497	80	80	2	$\frac{1}{2}$ " BSF	$\frac{13}{16}$	0.78	0.30	4.2	0.67	$\frac{3}{4}$	0.42
498	90	90	2	$\frac{13}{16}$ " BSF	$\frac{7}{8}$	0.78	0.34	4.3	0.72	$\frac{1}{2}$	0.46

For Turnbuckles (Tension Rod Type) see B.S. SP8

Brown Brothers Engineering Ltd

B.S. 2SP7

FORK JOINTS (High Tensile)

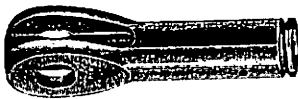
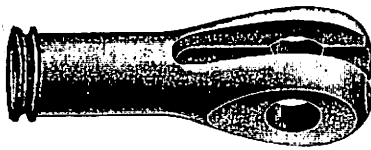

Fork with collar omitted indicates Stainless Steel.

Material :
H.T. STEEL
(CADMIUM)
OR
STAINLESS STEEL

Alternative design when Cold Headed for Forks up to and including size J ($\frac{3}{8}$ " BSF)

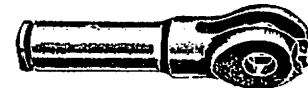

Fork without raised ring indicates Stainless Steel.

PART No.		THREADS	DIAMETER OF PIN HOLE	WIDTH OVER JAWS	WIDTH BETWEEN JAWS	SLOT DEPTH FROM PIN CENTRE MIN.	PIN SP4	MINIMUM TENSILE STRENGTH
R.H.	L.H.							
B	BL	4 BA	$\frac{1}{8}$ IN.	0.25	0.07	0.30	A 2	LBS. 1,155
C	CL	2 BA	$\frac{3}{16}$	0.30	0.10	0.35	B 3	2,090
E	EL	$\frac{1}{4}$ " BSF	$\frac{1}{4}$	0.41	0.125	0.50	D 5	3,795
G	GL	$\frac{5}{16}$ " BSF	$\frac{1}{2}$	0.50	0.14	0.65	G 7	6,270
J	JL	$\frac{3}{8}$ " BSF	$\frac{3}{4}$	0.60	0.17	0.75	J 9	9,350
L	LL	$\frac{7}{16}$ " BSF	$\frac{3}{4}$	0.68	0.188	0.90	L 10	12,980
N	NL	$\frac{1}{2}$ " BSF	$\frac{1}{2}$	0.77	0.25	1.05	N 13	17,050
P	PL	$\frac{9}{16}$ " BSF	$\frac{7}{8}$	0.70	0.281	1.81	P 11	21,230
Q	QL	$\frac{5}{8}$ " BSF	$\frac{7}{8}$	0.75	0.313	1.87	Q 12	25,990
R	RL	$\frac{11}{16}$ " BSF	$\frac{7}{8}$	0.83	0.350	1.86	R 13	32,570
S	SL	$\frac{3}{4}$ " BSF	$1\frac{1}{8}$	0.90	0.375	2.00	T 15	37,970

When ordering : The letter " Y " must precede Part No. for non-Stainless Steel, e.g. 2SP7 Y,CL.
The letter " Z " must precede Part No. for Stainless Steel, e.g. 2SP7 Z,CL.

See B.S. 3SP3 for Low Tensile Forks

Brown Brothers Engineering Ltd

B.S. SP8

TENSION RODS

Material : H.T. STEEL (CADMIUM) or STAINLESS STEEL

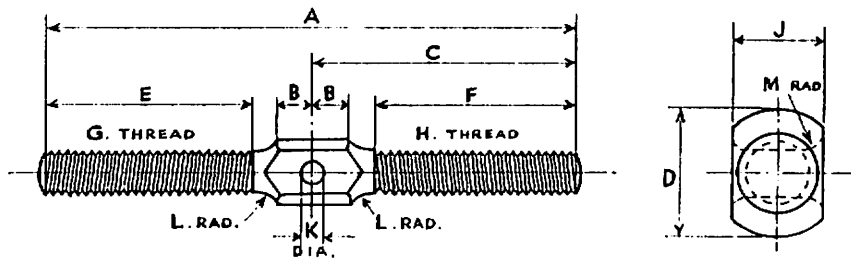

WHEN ORDERING :

THE LETTER "Y" MUST PRECEDE PART NO. FOR NON-STAINLESS STEEL, e.g. SP8 Y,4A.

THE LETTER "Z" MUST PRECEDE PART NO. FOR STAINLESS STEEL, e.g. SP8 Z,4A.

TABLE 3

1	2	3	4	5	6	7	8	9	10	11	12	13	14
PART NO.	A	B	O	D	H	F	I LEFT HAND THREAD	II RIGHT HAND THREAD	J	K	L	M	MINIMUM BREAKING LOAD
1	IN. 2.86	IN. 0.25	IN. 1.43	IN. 0.28	IN. 0.89	IN. 0.89	4BA	4BA	IN. 0.19	IN. 3/4	IN. 0.10	IN. 0.03	CWT. 5
1A	3.08	0.25	1.61	0.28	0.89	1.06	4BA	2BA	0.19	3/4	0.10	0.03	10
2	3.20	0.25	1.60	0.30	1.06	1.06	2BA	2BA	0.19	5/8	0.10	0.03	15
4	3.46	0.25	1.73	0.30	1.18	1.18	1" BSF	1" BSF	0.27	3/4	0.12	0.03	25
4A	3.68	0.25	1.91	0.36	1.18	1.35	1" BSF	5/8" BSF	0.32	3/4	0.12	0.03	35
6	4.00	0.30	2.00	0.46	1.35	1.35	5/8" BSF	1 1/8" BSF	0.32	3/4	0.12	0.04	46
8	4.52	0.30	2.26	0.48	1.51	1.51	1" BSF	1" BSF	0.38	3/4	0.12	0.04	75
12	5.30	0.35	2.65	0.58	1.79	1.79	1" BSF	1" BSF	0.50	3/4	0.12	0.05	120

B.S. SP8

ROLLERS

**Material : STEEL (CADMIUM) or
STAINLESS STEEL**

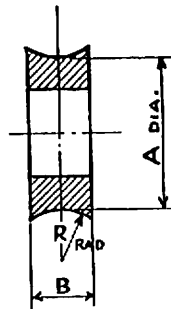
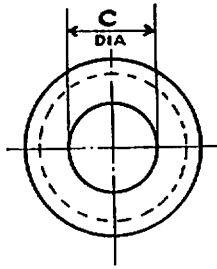

WHEN ORDERING :

**THE LETTER "Y" MUST PRECEDE PART NO. FOR
NON-STAINLESS STEEL, e.g. SP8 Y,13.**

**THE LETTER "Z" MUST PRECEDE PART NO. FOR
STAINLESS STEEL, e.g. SP8 Z,13.**

TABLE 4

ITEM No.	A	B	C	R RADIUS
13	IN. 0.266	IN. 0.095	IN. $\frac{5}{32}$	IN. 0.075
14	0.338	0.145	$\frac{3}{16}$	0.10
16	0.428	0.195	$\frac{1}{4}$	0.15
18	0.520	0.240	$\frac{11}{32}$	0.20
20	0.576	0.290	$\frac{13}{32}$	0.20
24	0.825	0.380	$\frac{13}{16}$	0.25

Brown Brothers Engineering Ltd

B.S. SP8

TURNBUCKLES (TENSION ROD TYPE)

Material :

NON-STAINLESS STEEL
(CADMIUM) OR
STAINLESS STEEL

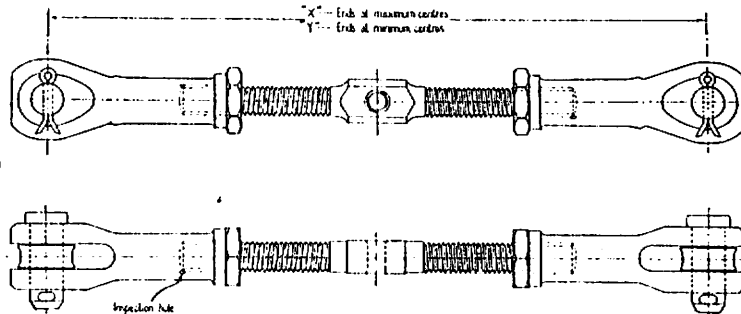

WHEN ORDERING :

THE LETTER "Y" MUST PRECEDE PART NO. FOR NON-STAINLESS STEEL, e.g. SP8 Y,412L.
THE LETTER "Z" MUST PRECEDE PART NO. FOR STAINLESS STEEL, e.g. SP8 Z,412L.

TABLE 1.—TURNBUCKLES FOR USE WITH TWO ROLLERS.

SIZE NO.	ADJUSTMENT X-Y	TO TAKE FLEXIBLE STEEL WIRE ROPE TO B.S. W2		FORK JOINT U.S. SP3			THIN NUTS B.S. A16		TENSION ROD TABLE 3	ROLLER TABLE 4	PIN U.S. SP4		SPLIT PIN	
		SIZE	ITEM NO. IN B.S. W2	1 OFF NOM. SIZE	1 OFF PART NO.	1 OFF PART NO.	1 OFF PART NO.	1 OFF PART NO.	1 OFF PART NO.	2 OFF PART NO.	1 OFF PART NO.	1 OFF PART NO.	2 OFF DIAM.	OVER-ALL LENGTH
5	0-9	5	4	4 BA	412L	412	BTL	BT	1	13	A2	A2	1/4	1/2
15	1-1	10	6 and 41	2 BA	413L	413	CTL	CT	2	14	B3	B3	1/2	3/4
25	1-2	25	51 and 44	BSF 1/4"	414L	414	ETL	ET	4	16	D6	D6	3/4	1
	45A	35	52 and 45	BSF 3/8"	416L	416	GTL	GT	6	18	G10	G10	1 1/4	1 1/2
75	1-6	60	54 and 47	BSF 1/2"	418L	418	JTL	JT	8	20	J12	J12	1	1
		70	55											
120A	1-75	120	58 and 72	BSF 3/4"	422L	422	NTL	NT	12	24	N16	N16	1 1/2	1 3/4

TABLE 2.—TURNBUCKLES FOR USE WITH ONE ROLLER AND ONE WIRING LUG.

Note.—The Roller is assembled in Right-hand Fork Joint.

SIZE NO.	ADJUSTMENT X-Y	TO TAKE FLEXIBLE STEEL WIRE ROPE TO B.S. W2		FORK JOINT U.S. SP3				THIN NUTS B.S. A16		TENSION ROD (TABLE 3)	ROLLER (TABLE 4)	PIN U.S. SP4		SPLIT PIN	
		SIZE	ITEM NO. IN B.S. W2	1 OFF NOM. SIZE	1 OFF PART NO.	1 OFF NOM. SIZE	1 OFF PART NO.	1 OFF PART NO.	1 OFF PART NO.	1 OFF PART NO.	1 OFF PART NO.	1 OFF PART NO.	1 OFF PART NO.	2 OFF DIAM.	OVER-ALL LENGTH
5	0-9	5	4	4BA	412L	4BA	412	BTL	BT	1	13	A2	A2	1/4	1/2
10	1-0	10	5 and 41	4BA	412L	2BA	413	BTL	CT	1A	14	A2	B3	1/2	3/4
15	1-1	15	6 and 42	2BA	413L	2BA	413	CTL	CT	2	14	B3	B3	3/4	1
25	1-2	25	51 and 44	BSF 1/4"	414L	BSF 1/4"	414	ETL	ET	4	16	D6	D6	3/4	1
35	1-3	35	52 and 45	BSF 1/4"	414L	BSF 3/8"	416	ETL	GT	4A	18	D6	G10	1 1/4	1 1/2
75	1-6	75	48	BSF 1/2"	418L	BSF 1/2"	418	JTL	JT	8	20	J12	J12	1	1

Stainless Sets comprise S.S. Forks, Pins and Split Pins, Rods and Rollers

Brown Brothers Engineering Ltd

B.S. SP9

SPLIT COTTER PINS (Non-Corrodible)

(Replaced by SP90.) See equivalent chart page 182



**Material: NICKEL ALLOY or
NICKEL-COPPER ALLOY**

ITEM	A	B	C	E	G	H	K	L
Nom. Dia.	IN. $\frac{1}{32}$	IN. $\frac{3}{64}$	IN. $\frac{1}{16}$	IN. $\frac{3}{32}$	IN. $\frac{1}{8}$	IN. $\frac{5}{32}$	IN. $\frac{3}{16}$	IN. $\frac{1}{4}$

METHOD OF ORDERING :

Part No. consists of the Item Letter followed by the nominal length in $\frac{1}{16}$ ths of an inch. *E.g.* the complete Part No. reference for a $\frac{1}{16}$ " nominal diameter split cotter pin with a nominal length of $\frac{5}{16}$ " is therefore: SP9/C5.

B.S. SPI0, SPII
(MILD STEEL) (STAINLESS
(Cadmium) STEEL)

WASHERS—26 S.W.G. (.018")

B.S. SPI3, SPI4, SPI5
(MILD STEEL) (STAINLESS) (ALUM.
(Cadmium) STEEL) (ALLOY)

WASHERS—18 S.W.G. (.048")

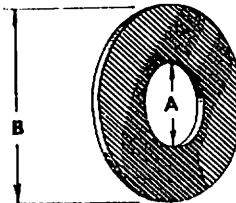

To Suit Bolts	ITEM	A		B	
		MAX.	MIN.	MAX.	MIN.
6 BA	A	IN. 0.123	IN. 0.118	IN. 0.233	IN. 0.228
4 BA	B	0.157	0.152	0.301	0.296
2 BA	C	0.202	0.197	0.391	0.386
$\frac{1}{4}$ " BSF	E	0.270	0.265	0.520	0.510
$\frac{5}{16}$ " BSF	G	0.333	0.328	0.610	0.600
$\frac{3}{8}$ " BSF	J	0.395	0.390	0.700	0.690
$\frac{7}{16}$ " BSF	L	0.458	0.453	0.820	0.810
$\frac{1}{2}$ " BSF	N	0.520	0.515	0.950	0.940
$\frac{5}{8}$ " BSF	P	0.583	0.578	1.070	1.060
$\frac{3}{4}$ " BSF	Q	0.645	0.640	1.170	1.160
$\frac{7}{8}$ " BSF	S	0.770	0.765	1.390	1.380
$\frac{15}{16}$ " BSF	U	0.895	0.890	1.500	1.490
1" BSF	W	1.025	1.015	1.710	1.700

Brown Brothers Engineering Ltd

B.S. SPI6 ALUMINIUM ALLOY WASHERS—12 S.W.G. (.104") (SELF-FINISH)

To Suit Bolts	ITEM	A		B	
		Max.	Min.	Max.	Min.
6 BA	A	IN. 0.123	IN. 0.118	IN. 0.233	IN. 0.228
4 BA	B	0.157	0.152	0.301	0.296
2 BA	C	0.202	0.197	0.391	0.386
1/4" BSF	E	0.270	0.265	0.520	0.510
5/16" BSF	G	0.333	0.328	0.610	0.600
3/8" BSF	J	0.395	0.390	0.700	0.690
7/16" BSF	L	0.458	0.453	0.820	0.810
1/2" BSF	N	0.520	0.515	0.950	0.940
5/8" BSF	P	0.583	0.578	1.070	1.060
3/4" BSF	Q	0.645	0.640	1.170	1.160
7/8" BSF	S	0.770	0.765	1.390	1.380
1" BSF	U	0.895	0.890	1.500	1.490
1" BSF	W	1.025	1.015	1.710	1.700

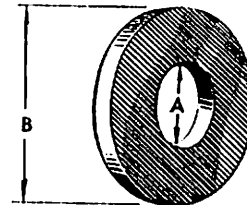

B.S. SPI8, SPI9 WASHERS (MILD STEEL) (STAINLESS STEEL) (Cadmium) (STEEL)

To Suit Bolts	ITEM	A		B		THICKNESS C
		Max.	Min.	Max.	Min.	
6 BA	A	IN. 0.123	IN. 0.118	IN. 1.01	IN. 0.99	0.064" (16 SWG)
4 BA	B	0.157	0.152	1.01	0.99	0.064" (16 SWG)
2 BA	C	0.202	0.197	1.26	1.24	0.064" (16 SWG)
1/4" BSF	E	0.270	0.265	1.26	1.24	0.064" (16 SWG)
5/16" BSF	G	0.333	0.328	1.26	1.24	0.064" (16 SWG)
3/8" BSF	J	0.395	0.390	1.51	1.49	0.080" (14 SWG)
7/16" BSF	L	0.458	0.453	1.51	1.49	0.080" (14 SWG)
1/2" BSF	N	0.520	0.515	1.51	1.49	0.080" (14 SWG)

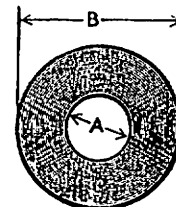

Brown Brothers Engineering Ltd

B.S. SP21

LUBRICATING NIPPLE

(Formerly known as AGS 554)

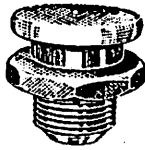

Material: LIGHT ALLOY (Anodised)

MINIATURE HOOK-ON TYPE

B.S. SP22 to SP27

B.A. WASHERS

(Primarily for instrument use)

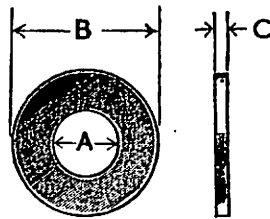

Material :

SP22, SP25 BRASS (Electro-tinned)

SP23, SP26 STEEL (Cadmium)

SP24, SP27 AUSTENITIC CHROMIUM-NICKEL RUST, ACID- AND HEAT-RESISTING
STEEL (Self-finish)

To Suit SCREWS	CODE LETTER	A DIAMETER		LARGE WASHERS SP22, SP23 and SP24			SMALL WASHERS SP25, SP26 and SP27		
				B DIAMETER		C	B DIAMETER		C
		MAX.	MIN.	MAX.	MIN.	THICKNESS	MAX.	MIN.	THICKNESS
2 BA	C	IN. 0.202	IN. 0.197	IN. 0.500	IN. 0.495	IN. 0.048 (18 SWG)	IN. 0.391	IN. 0.386	IN. 0.032 (21 SWG)
4 BA	B	0.157	0.152	0.378	0.373	0.040 (19 SWG)	0.301	0.296	0.028 (22 SWG)
6 BA	A	0.123	0.118	0.288	0.283	0.036 (20 SWG)	0.233	0.228	0.024 (23 SWG)
8 BA	Z	0.099	0.094	0.228	0.223	0.020 (25 SWG)	0.185	0.180	0.020 (25 SWG)
10 BA	Y	0.078	0.073	0.176	0.171	0.016 (27 SWG)	—	—	—

Brown Brothers Engineering Ltd

B.S. SP28, SP29, SP30 SOLID TAPER PINS

Material :

SP28 HIGH TENSILE STEEL (Cadmium)

SP29 STAINLESS STEEL

SP30 ALUMINIUM ALLOY (Anodised)

(SP30 replaced by SP65)

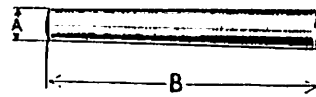

ITEM	E	G	H	K	L	N	P	R
Diameter at small end "A" (Nom.)	$\frac{1}{16}$ "	$\frac{3}{32}$ "	$\frac{1}{8}$ "	$\frac{3}{16}$ "	$\frac{1}{4}$ "	$\frac{5}{16}$ "	$\frac{3}{8}$ "	$\frac{1}{2}$ "

METHOD OF ORDERING

The part reference number consists of the item letter followed by the item number which represents the nominal length "B" in $\frac{1}{8}$ of an inch. The complete part number for a $\frac{1}{8}$ " diameter \times $1\frac{1}{2}$ " long stainless steel pin is therefore SP29/H12.

B.S. SP31, SP32 SPLIT TAPER PINS

Material :

SP31 HIGH TENSILE STEEL (Cadmium)

SP32 STAINLESS STEEL

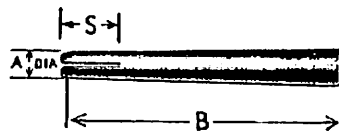

ITEM	DIAM. AT SMALL END "A" (Nom.)	NOMINAL LENGTH "B"									
		$\frac{1}{8}$ "	$\frac{1}{4}$ "	1"	$1\frac{1}{4}$ "	$1\frac{1}{2}$ "	$1\frac{3}{4}$ "	2"	$2\frac{1}{2}$ "	3"	4"
		NOMINAL LENGTH "S"									
H	$\frac{1}{8}$	$\frac{1}{8}$	$\frac{1}{4}$	$\frac{5}{16}$	$\frac{3}{8}$	$\frac{1}{2}$	$\frac{5}{8}$	$\frac{3}{4}$	—	—	—
K	$\frac{3}{16}$	—	$\frac{1}{4}$	$\frac{5}{16}$	$\frac{3}{8}$	$\frac{1}{2}$	$\frac{5}{8}$	$\frac{3}{4}$	$\frac{7}{8}$	$\frac{1}{2}$	—
L	$\frac{1}{4}$	—	$\frac{1}{4}$	$\frac{3}{8}$	$\frac{1}{2}$	$\frac{5}{8}$	$\frac{3}{4}$	$\frac{7}{8}$	$\frac{1}{2}$	$\frac{3}{4}$	$\frac{5}{8}$
N	$\frac{5}{16}$	—	$\frac{5}{16}$	$\frac{3}{8}$	$\frac{1}{2}$	$\frac{5}{8}$	$\frac{3}{4}$	$\frac{7}{8}$	$\frac{1}{2}$	$\frac{3}{4}$	$\frac{5}{8}$
P	$\frac{3}{8}$	—	—	—	—	—	$\frac{3}{8}$	$\frac{1}{2}$	$\frac{5}{8}$	$\frac{3}{4}$	$\frac{7}{8}$
R	$\frac{1}{2}$	—	—	—	—	—	—	$\frac{1}{2}$	$\frac{3}{4}$	$\frac{1}{2}$	$\frac{3}{4}$

METHOD OF ORDERING

The part reference number consists of the item letter followed by the item number which represents the nominal length "B" in $\frac{1}{8}$ of an inch. The complete part number for $\frac{1}{8}$ " diameter \times $1\frac{1}{2}$ " long stainless steel pin is therefore SP32/H12.

Brown Brothers Engineering Ltd

B.S. SP33

BA & BSF TURNBARRELS

Material : MILD STEEL (Cadmium and Temporary Rust Preventative)

B.S. SP34

BA & BSF SCREWED ENDS (for Swaged Cable-end Connections)

Material : HIGH TENSILE STEEL (Cadmium)

(For Tension Rods and Tapped Ends, see B.S. SP35 and SP36)

(For Turnbarrels and Screwed Ends with Unified Threads, see 2SP101 and 2SP102)

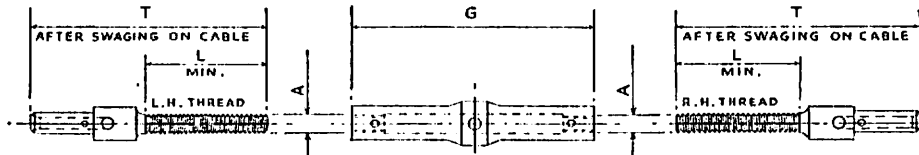

Screwed End (L.H.)
B.S. SP34

Turnbarrel
B.S. SP33

Screwed End (R.H.)
B.S. SP34

CABLE SIZE CWT.	CODE LETTERS	A	L	T
5	B5L	4 BA	IN. 0.95	IN. 1.85
5	C5L	2 BA	1.65	2.56
10	C10L	2 BA	1.65	2.81
10	E10L	1/4" BSF	1.71	2.90
15	C15L	2 BA	1.65	2.93
15	E15L	1/4" BSF	1.71	3.02
20	E20L	1/4" BSF	1.71	3.16
20	G20L	3/8" BSF	1.79	3.26
25	E25L	1/4" BSF	1.71	3.33
25	G25L	3/8" BSF	1.79	3.41
30/35	E30L	1/4" BSF	1.71	3.45
30/35	G35L	3/8" BSF	1.79	3.55
40/45	G45L	3/8" BSF	1.79	3.79

CODE LETTER	A	G
B	4 BA	IN. 1.91
C	2 BA	3.26
E	1/4" BSF	3.36
G	3/8" BSF	3.50

CABLE SIZE CWT.	CODE LETTER	A	L	T
5	B5	4 BA	IN. 0.95	IN. 1.85
5	C5	2 BA	1.65	2.56
10	C10	2 BA	1.65	2.81
10	E10	1/4" BSF	1.71	2.90
15	C15	2 BA	1.65	2.93
15	E15	1/4" BSF	1.71	3.02
20	E20	1/4" BSF	1.71	3.16
20	G20	3/8" BSF	1.79	3.26
25	E25	1/4" BSF	1.71	3.33
25	G25	3/8" BSF	1.79	3.41
30/35	E30	1/4" BSF	1.71	3.45
30/35	G35	3/8" BSF	1.79	3.55
40/45	G45	3/8" BSF	1.79	3.79

Turnbarrels are ordered by the specification number followed by the code letter of the size required, e.g. a 2 BA turnbarrel would be SP33/C.

Screwed ends are ordered by the specification number followed by the code letters of the size required, e.g. a 1/4" BSF (right hand) suitable for a 15 cwt. cable would be SP34/E15 and a 2 BA (left hand) suitable for a 10 cwt. cable would be SP34/C10L.

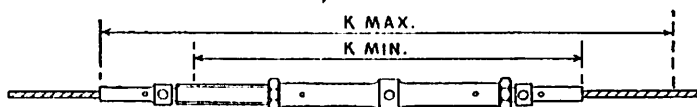

Dimensions of Assemblies

CABLE SIZE CWT.	5	5	10	10	15	15	20	20	25	25	30/35	30/35	40/45
THREAD	4 BA	2 BA	2 BA	1/4" BSF	2 BA	1/4" BSF	1/4" BSF	1/4" BSF	1/4" BSF	1/4" BSF	1/4" BSF	1/4" BSF	1/4" BSF
K	MAX. IN.	5.08	7.72	8.22	8.40	8.46	8.64	8.92	9.16	9.26	9.49	9.50	10.21
	MIN. IN.	3.88	5.32	5.82	6.00	6.06	6.24	6.52	6.75	6.86	7.09	7.10	7.81

Brown Brothers Engineering Ltd

B.S. SP35

BA & BSF TENSION RODS

Material : HIGH TENSILE STEEL (Cadmium)

B.S. SP36

BA & BSF TAPPED ENDS

(for Swaged Cable-end Connections)

Material : MILD STEEL (Cadmium and Temporary Rust Preventative)

(For Turnbarrels and Screwed Ends, see B.S. SP33 and SP34)

(For Tension Rods and Tapped Ends with Unified Threads, see 2SP103 and 2SP104)



Tension Rod (Even Ends). B.S. SP35

CABLE SIZE CWT.	CODE LETTERS	A	T
5	B5L	4 BA	IN. 1.77
5	C5L	2 BA	2.49
10	C10L	2 BA	2.67
10	E10L	1/4" BSF	2.74
15	C15L	2 BA	2.79
15	E15L	1/4" BSF	2.85
20	E20L	1/4" BSF	2.91
20	G20L	3/8" BSF	3.01
25	E25L	1/4" BSF	3.06
25	G25L	3/8" BSF	3.15
30/35	E30L	1/4" BSF	3.17
30/35	G35L	3/8" BSF	3.27
40/45	G45L	3/8" BSF	3.48

CODE LETTER	A	B	E
B	4 BA	4 BA	IN. 0.95
C	2 BA	2 BA	1.65
E	1/4" BSF	1/4" BSF	1.71
G	3/8" BSF	3/8" BSF	1.79

Tapped End (R.H.)
B.S. SP36

CABLE SIZE CWT.	CODE LETTER	B	T
5	B5	4 BA	IN. 1.77
5	C5	2 BA	2.49
10	C10	2 BA	2.67
10	E10	1/4" BSF	2.74
15	C15	2 BA	2.79
15	E15	1/4" BSF	2.85
20	E20	1/4" BSF	2.91
20	G20	3/8" BSF	3.01
25	E25	1/4" BSF	3.06
25	G25	3/8" BSF	3.15
30/35	E30	1/4" BSF	3.17
30/35	G35	3/8" BSF	3.27
40/45	G45	3/8" BSF	3.48

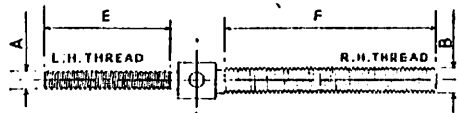

Tension Rod (Odd Ends). B.S. SP35

CODE LETTERS	A	B	E	F
BC	4 BA	2 BA	0.95	1.65
CB	2 BA	4 BA	1.65	0.95
CE	2 BA	1/4" BSF	1.65	1.71
EC	1/4" BSF	2 BA	1.71	1.65
EG	1/4" BSF	3/8" BSF	1.71	1.79
GE	3/8" BSF	1/4" BSF	1.79	1.71

Tension rods are ordered by the specification number followed by the code letter(s) of the size required, e.g. a 2 BA tension rod (even ends) would be SP35/C and a 1/4" BSF (left hand) and 2 BA (right hand) tension rod (odd ends) would be SP35/EC.

Tapped ends are ordered by the specification number followed by the code letters of the size required, e.g. a 1/4" BSF (right hand) suitable for a 15 cwt. cable would be SP36/E15 and a 2 BA (left hand) suitable for a 10 cwt. cable would be SP36/C10L.

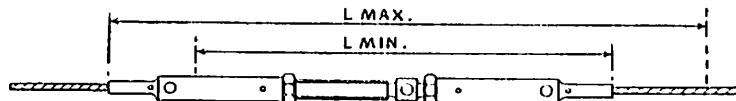

Dimensions of Assemblies

CABLE SIZE CWT.	5	5	10	10	15	16	20	20	25	25	30/35	30/35	40/45
THREAD	4 BA	2 BA	2 BA	1/4" BSF	2 BA	1/4" BSF	1/4" BSF	3/8" BSF	1/4" BSF	3/8" BSF	1/4" BSF	3/8" BSF	3/8" BSF
L	MAX.	5.31	5.04	5.40	5.72	5.64	5.94	6.00	6.35	6.34	6.63	6.58	6.89
	MIN.	4.11	5.64	6.00	6.32	6.21	6.54	6.66	6.95	6.94	7.23	7.18	7.47

Brown Brothers Engineering Ltd

B.S. SP37, SP38, SP39 SWAGED CABLE-END CONNECTIONS

SP37 EYE ENDS
 SP38 FORK ENDS
 SP39 EYE ENDS FOR CHAIN

Material :
 MILD STEEL (Cadmium)

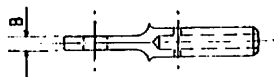
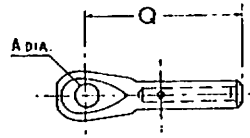
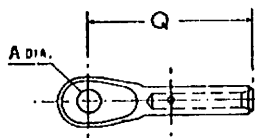

Eye End
 B.S. SP37

Fork End
 B.S. SP38

CABLE SIZE CWT.	5	10	15	20	25	30/35	40/45
CODE LETTER	A	B	C	D	E	F	G
A	$\frac{1}{2}$ "	$\frac{3}{8}$ "	$\frac{3}{8}$ "	$\frac{1}{2}$ "	$\frac{1}{2}$ "	$\frac{1}{2}$ "	$\frac{3}{8}$ "
B	IN. 0.096	IN. 0.096	IN. 0.146	IN. 0.196	IN. 0.196	IN. 0.196	IN. 0.246
C	0.100	0.100	0.150	0.200	0.200	0.200	0.250
Q	0.94	1.21	1.41	1.58	1.75	1.93	2.27

Eye ends and fork ends are ordered by the specification number followed by the code letter of the size required, e.g. an eye end suitable for a 10 cwt. cable would be SP37/B and a fork end suitable for a 20 cwt. cable would be SP38/D.



Eye End for Chain
 B.S. SP39

CHAIN SIZE (BS228)	BS1	BS1	BS2	BS4	BS2	BS4	BS4	BS6	BS6	BS6	BS10	BS10
CABLE SIZE CWT.	5	10	10	10	15	15	20	20	25	30/35	30/35	40/45
CODE NUMBERS	1-5	1-10	2-10	4-10	2-15	4-15	4-20	6-20	6-25	6-30	10-35	10-45
A	IN. 0.093	IN. 0.093	IN. 0.131	IN. 0.162	IN. 0.131	IN. 0.162	IN. 0.162	IN. 0.181	IN. 0.181	IN. 0.181	IN. 0.206	IN. 0.206
F	0.186	0.186	0.261	0.232	0.261	0.232	0.232	0.344	0.344	0.344	0.400	0.400

Eye ends for chain are ordered by the specification number followed by the code numbers of the size required, e.g. an eye end suitable for a BS4 chain and a 10 cwt. cable would be SP39/4-10.

Brown Brothers Engineering Ltd

B.S. SP40

(RUBBER)

B.S. SP93 & SP95

(RUBBER-NITRILE) (RUBBER-NEOPRENE)

GROMMETS

(SELF-FINISH)

(SP40 replaces AGS 1696)

(SP40 replaced by SP93 and SP95)

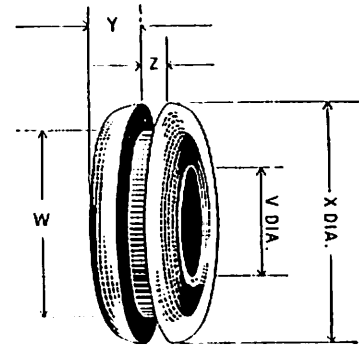

ITEM LETTER	A	B	C	D	E	F
Z	0.04"	0.07"	0.10"	0.15"	0.20"	0.25"

V	W	X	Y
$\frac{1}{8}$ IN.	$\frac{1}{4}$ IN.	0.375 IN.	0.094 IN.
$\frac{3}{16}$	$\frac{5}{16}$	0.438	0.094
$\frac{1}{4}$	$\frac{3}{8}$	0.500	0.094
$\frac{5}{16}$	$\frac{7}{16}$	0.625	0.125
$\frac{3}{8}$	$\frac{1}{2}$	0.688	0.125
$\frac{7}{16}$	$\frac{5}{8}$	0.813	0.125
$\frac{1}{2}$	$\frac{11}{16}$	0.875	0.125
$\frac{9}{16}$	$\frac{3}{4}$	1.000	0.125
$\frac{5}{8}$	$\frac{13}{16}$	1.063	0.125

V	W	X	Y
$\frac{11}{16}$ IN.	$\frac{15}{16}$ IN.	1.188 IN.	0.125 IN.
$\frac{3}{4}$	1	1.250	0.125
$\frac{7}{8}$	$1\frac{1}{8}$	1.438	0.156
1	$1\frac{1}{4}$	1.563	0.156
$1\frac{1}{8}$	$1\frac{3}{8}$	1.688	0.156
$1\frac{1}{4}$	$1\frac{1}{2}$	1.813	0.156
$1\frac{3}{8}$	$1\frac{5}{8}$	1.938	0.156
$1\frac{1}{2}$	$1\frac{3}{4}$	2.125	0.188
$1\frac{7}{8}$	2	2.375	0.188
2	$2\frac{1}{4}$	2.625	0.188

METHOD OF ORDERING

The part reference number consists of the item letter followed by the item number which represents the "V" diameter in $\frac{1}{32}$ of an inch. The complete part number for a Rubber Grommet with a "Z" width of 0.07" and a "V" diameter of $\frac{1}{4}$ " is therefore SP40/B8.

Brown Brothers Engineering Ltd

TAB WASHERS

BA & BSF—B.S. SP41 to SP46
UNIFIED—B.S. SPI07 to SPI12

Material :

SP41 & SPI07
MILD STEEL (Cadmium)
SP42 & SPI08
STAINLESS STEEL

SP43 & SPI09
MILD STEEL (Cadmium)
SP44 & SPI10
STAINLESS STEEL

SP45 & SPI11
MILD STEEL (Cadmium)
SP46 & SPI12
STAINLESS STEEL

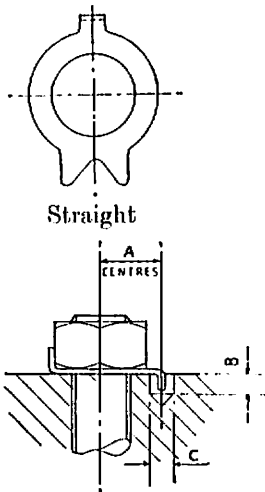

Straight

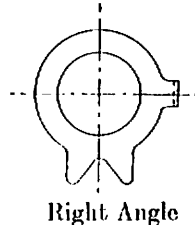

Right Angle

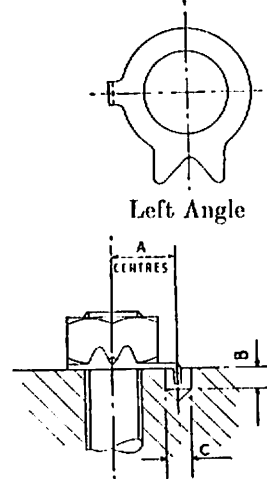

Left Angle

Recommended
application of
Tab Washer

BA/BSF

TO SUIT THREAD SIZE	2 BA	1" BSF	3/8" BSF	1/2" BSF	5/8" BSF	3/4" BSF	7/8" BSF	1" BSF	1 1/8" BSF	1 1/4" BSF	1 1/2" BSF	1 3/4" BSF
ITEM	C	E	G	J	L	N	P	Q	S	U	W	
A	0.225"	0.275"	0.335"	0.375"	0.425"	0.475"	0.550"	0.575"	0.675"	0.800"	0.875"	
B	0.105"	0.115"	0.115"	0.155"	0.165"	0.165"	0.165"	0.165"	0.165"	0.165"	0.165"	
C DRILL	1"	1"	1 1/2"	1 1/2"	1 3/4"	1 3/4"	1 3/4"	1 3/4"	1"	1 1/2"	1 1/2"	

UNIFIED

TO SUIT THREAD SIZE	No. 8 (0.313" A/F)	No. 10 (0.344" A/F)	No. 10 (0.375" A/F)	1" UNF	3/8" UNF	1/2" UNF	5/8" UNF	3/4" UNF	7/8" UNF	1" UNF	1 1/8" UNF	1 1/4" UNF	1 1/2" UNF	
ITEM	A	D		G	J	L	N	P	Q	S	U	W		
A	0.197"	0.225"	USE SP41-46 ITEM C	USE SP41-46 ITEM E	0.335"	0.375"	0.425"	0.475"	0.550"	0.575"	0.675"	0.800"	0.875"	
B	0.100"	0.112"			0.115"	0.155"	0.165"	0.165"	0.165"	0.165"	0.165"	0.165"	0.165"	
C DRILL	3/8"	1"			1 1/2"	1 1/2"	1 3/4"	1 3/4"	1 3/4"	1 3/4"	1"	1 1/2"	1 1/2"	

METHOD OF ORDERING

The specification number is suffixed by the item letter. *E.g.* a straight tab washer in mild steel to suit a 1/2" BSF thread would be SP41/E. A left angle tab washer in stainless steel to suit a 1/2" Unified thread would be SPI12/N.

Brown Brothers Engineering Ltd

B.S. 2SP47

SINGLE COIL SPRING WASHERS

(Replacing AGS 162, 517 and 585)

Material :
SPRING STEEL (CADMIUM)

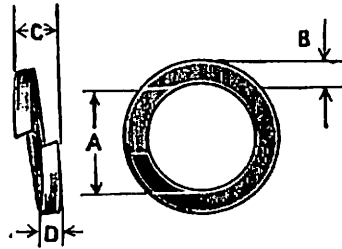

To Suit NOM. THREAD SIZE	ITEM LETTER	A		B		C		D	
		MAX.	MIN.	MAX.	MIN.	MAX.	MIN.	MAX.	MIN.
10 BA	Y	IN. 0.071	IN. 0.068	IN. 0.033	IN. 0.028	IN. 0.060	IN. 0.040	IN. 0.023	IN. 0.020
8 BA	Z	0.091	0.088	0.042	0.036	0.070	0.050	0.028	0.024
6 BA & No. 4-40 UNC	A	0.116	0.113	0.064	0.056	0.092	0.072	0.041	0.036
No. 6-32 UNC	B	0.146	0.143	0.082	0.072	0.092	0.072	0.041	0.036
No. 8-32 UNC	X	0.168	0.165	0.090	0.080	0.100	0.080	0.045	0.040
2 BA & No. 10-32 UNF	C	0.195	0.191	0.102	0.092	0.116	0.096	0.053	0.048
1/8" dia.	E	0.256	0.251	0.138	0.128	0.150	0.120	0.061	0.056
5/16" dia.	G	0.320	0.314	0.150	0.140	0.180	0.150	0.069	0.064
3/8" dia.	J	0.383	0.376	0.170	0.160	0.200	0.170	0.077	0.072
7/16" dia.	L	0.447	0.439	0.186	0.176	0.220	0.190	0.077	0.072
1/2" dia.	N	0.510	0.501	0.220	0.210	0.240	0.210	0.085	0.080
9/16" dia.	P	0.574	0.564	0.240	0.230	0.270	0.240	0.097	0.092
5/8" dia.	Q	0.636	0.626	0.270	0.260	0.290	0.260	0.109	0.104

B.S. SP49 & SP50 BALL ENDS FOR SWAGING ON CABLE

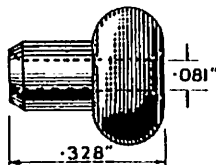

Before Swaging

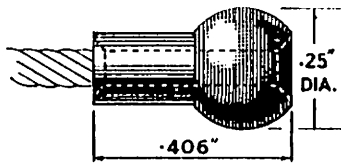

After Swaging

Material :
MILD STEEL (CADMIUM)

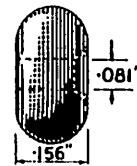

Before Swaging

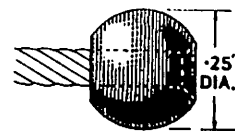

After Swaging

Ball End with Shank, SP49.

Ball End without Shank, SP50.

Brown Brothers Engineering Ltd

B.S. SP51 & SP52 IDENTIFICATION TAGS

Material : ALUMINIUM (SELF-FINISH)

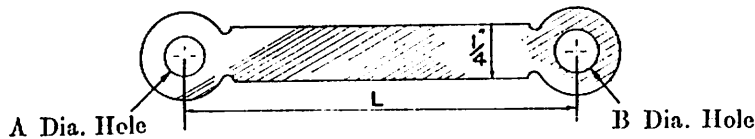

22 SWG (0.028")

B.S.	A	B	L
SP51	$\frac{9}{32}$ "	$\frac{13}{64}$ "	$1\frac{1}{2}$ "
SP52	$\frac{13}{64}$ "	$\frac{17}{64}$ "	2"

B.S. SP53 SWAGED CABLE END ASSEMBLIES (BA & BSF Threads for Preformed Steel Wire Rope)

(Suitable for use with B.S. W9 Wire Rope)

Details on request

B.S. SP54 SWAGED CABLE END ASSEMBLIES (BA & BSF Threads for Preformed Non-Corrodible Steel Wire Rope)

(Suitable for use with B.S. W11 Wire Rope)

Details on request

B.S. SP55 & SP56 DOUBLE COIL SPRING WASHERS

(Replacing AGS 163, 586, 1583 and 1607)

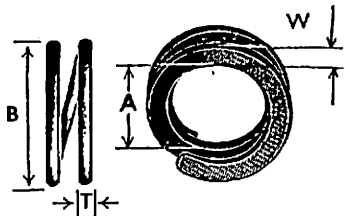

Material : SP55—STEEL (CADMIUM)
SP56—PHOSPHOR BRONZE (SELF-FINISH)

ITEM	NOM. SIZE	A		W	B		T
		MIN.	MAX.	NOM.	NOM.	MAX.	
A	6 BA	IN. 0.133	IN. 0.141	IN. 0.048	IN. 0.237	IN. 0.032	
B	4 BA	0.164	0.172	0.064	0.300	0.032	
C	2 BA	0.196	0.203	0.080	0.363	0.032	
E	$\frac{1}{2}$ "	0.267	0.281	0.116 0.092*	0.513 0.465*	0.040 0.048*	
G	$\frac{3}{8}$ "	0.328	0.344	0.116	0.576	0.048	

* Phosphor Bronze Washers only.

ITEM	NOM. SIZE	A		W	B		T
		MIN.	MAX.	NOM.	NOM.	MAX.	
J	1"	IN. 0.391	IN. 0.406	IN. 0.144	IN. 0.694	IN. 0.048	
L	$\frac{1}{2}$ "	0.453	0.469	0.144	0.757	0.064	
N	$\frac{3}{4}$ "	0.516	0.531	0.160	0.851	0.064	
P	$\frac{5}{16}$ "	0.594	0.625	0.192	1.009	0.064	
Q	$\frac{1}{2}$ "	0.656	0.688	0.192	1.072	0.080	

Brown Brothers Engineering Ltd

B.S. SP57 & SP58

RIVET BURRS
(Replacing AGS 190 and 191)

Material : SP57—COPPER (TINNED)
SP58—ALUMINIUM ALLOY (ANODISED)

DIM.	ITEM										
	A	B	C	D	E	F	G	H	J	K	L
A	$\frac{1}{8}$ "	$\frac{3}{16}$ "	$\frac{1}{4}$ "	$\frac{5}{16}$ "	$\frac{3}{8}$ "	$\frac{7}{16}$ "	$\frac{1}{2}$ "	$\frac{5}{8}$ "	$\frac{3}{4}$ "	$\frac{7}{8}$ "	$\frac{1}{2}$ "
B	IN. 0.35	IN. 0.40	IN. 0.45	IN. 0.55	IN. 0.65	IN. 0.70	IN. 0.80	IN. 0.85	IN. 0.90	IN. 1.00	IN. 1.10
C	0.028	0.028	0.028	0.028	0.028	0.036	0.036	0.036	0.036	0.018	0.018

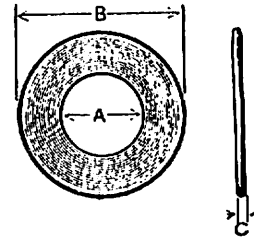

B.S. SP59 & SP60

SPRING CATCHES
(Replacing AGS 787)

Material : Item 1—PHOSPHOR BRONZE
Items 2, 3 and 4—BRASS (TINNED)

SP59 (RIGHT-HAND—AS SHOWN)		SP60 (LEFT-HAND—OPPOSITE)	
ITEM	DESCRIPTION	ITEM	DESCRIPTION
1	Spring Plate	1	Spring Plate
2	Catch Hook	2	Catch Hook
3	Back Plate	3	Back Plate
4	Stop Pin	4	Stop Pin

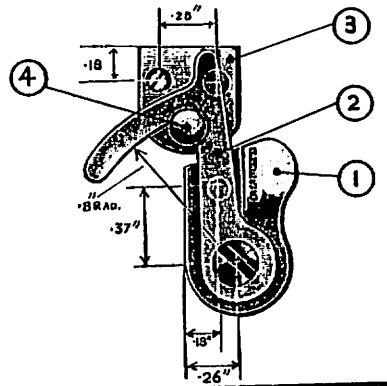

B.S. SP61 to SP64

WOOD SCREWS

(RECESSED HEADS)

(Superseded by SP128 to SP133)

Material:

90° Countersunk Head	Round Head
SP61—BRASS (SELF-FINISH)	SP62—BRASS (SELF-FINISH)
SP63—STEEL (CADMIUM)	SP64—STEEL (CADMIUM)

Available in gauge sizes No. 4, 6 and 8 only

Brown Brothers Engineering Ltd

B.S. SP65

SOLID TAPER PINS

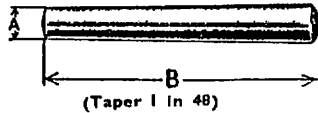

Material :

ALUMINIUM ALLOY (ANODISED & DYED BLUE)
(Replacing SP30)

ITEM	E	G	H	K	L	N	P	R
Diameter at small end "A" (Nom.)	$\frac{1}{16}$ "	$\frac{3}{32}$ "	$\frac{1}{4}$ "	$\frac{5}{32}$ "	$\frac{3}{8}$ "	$\frac{1}{2}$ "	$\frac{5}{16}$ "	$\frac{3}{4}$ "

METHOD OF ORDERING

The part reference number consists of the item letter followed by the item number which represents the nominal length "B" in $\frac{1}{8}$ of an inch. The complete part number for a $\frac{1}{8}$ " diameter \times $1\frac{1}{2}$ " long aluminium alloy pin is therefore SP65/H12.

B.S. SP66 BRASS-ELECTRO TINNED
B.S. SP67 STAINLESS STEEL

(Replaces AGS 136)
(Replaces AGS 969)

THIMBLES

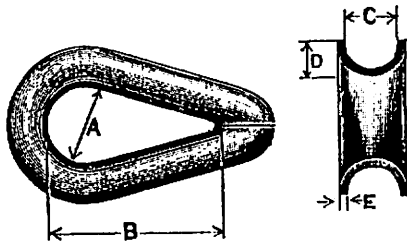

ITEM	To suit CABLE CAPACITY	A	B	C	D	E
A	5	0.35	0.7	0.12	0.08	24
B	10-15	0.4	0.8	0.17	0.11	24
C	20-25	0.5	1.0	0.21	0.135	22
D	30-35	0.6	1.2	0.24	0.155	20
E	40-45	0.7	1.4	0.27	0.17	20
F	65	0.8	1.6	0.30	0.19	20
G	75	0.9	1.8	0.33	0.21	18

B.S. SP68 to SP71 100° C'SK. PRECISION HEAD RIVETS

Material: ALUMINIUM & ALUMINIUM ALLOY

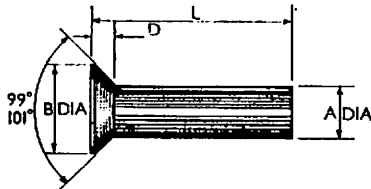

"A" DIA.	$\frac{1}{8}$ "	$\frac{3}{16}$ "	$\frac{1}{4}$ "	$\frac{5}{16}$ "	$\frac{3}{8}$ "	$\frac{1}{2}$ "	$\frac{5}{8}$ "	$\frac{3}{4}$ "	$\frac{7}{8}$ "
"B" DIA. MIN.	0.104	0.164	0.208	0.267	0.320	0.380	0.445	0.520	0.650
"D" DEPTH	0.022	0.036	0.042	0.055	0.070	0.082	0.095	0.100	0.134

BRITISH STANDARD No.	MATERIAL	FINISH		IDENT. MARK
		TREATMENT	COLOUR	
SP68	L36	Anodic or Chemical Oxidation	Black	1
SP69	4-L37	None	Plain	7
SP70	L58	Anodic or Chemical Oxidation	Green	8
SP71	L86	Anodic or Chemical Oxidation	Violet	0

METHOD OF ORDERING

Rivets to the above specifications are ordered by the British Standard Number, followed by the part number, the last two figures of the part number denoting the nominal length "L" in $\frac{1}{8}$ of an inch, the remaining figure or figures denoting the diam. in $\frac{1}{32}$ of an inch, e.g. the complete part number for a rivet in L58 material, $\frac{1}{8}$ " Diam. and $\frac{5}{8}$ " long, is SP70/410.

Brown Brothers Engineering Ltd

B.S. SP72 BRAIDED RUBBER CORD ASSEMBLIES

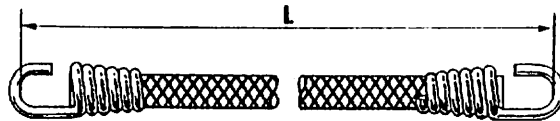

METHOD OF ORDERING

Cord assemblies shall be ordered by British Standard Number suffixed by:—

- 1 The cord specification number, e.g. F51.
- 2 The cord nominal diameter, e.g. $\frac{1}{4}$ ".
- 3 The unstretched length "L" in inches, e.g. 12"

e.g. the complete part number for a cord assembly consisting of F51 cord $\frac{1}{4}$ " nominal diameter 12" long is SP72/F51/ $\frac{1}{4}$ /12.

B.S. 2SP73

HOOK FERRULE FOR ELASTIC CORD

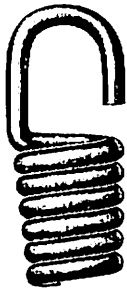

Material:

SPRING
STEEL
WIRE

ITEM LETTER	TO SUIT CORD DIA.	S.W.G.
A	$\frac{3}{16}$ "	16
B	$\frac{1}{4}$ "	14
C	$\frac{5}{16}$ "	12
D	$\frac{3}{8}$ "	11
F	$\frac{1}{2}$ "	10
G	$\frac{5}{8}$ "	8

B.S. 2SP74 ASSEMBLY WIRES

Material:

MILD STEEL WIRE (CADMIUM)

FOR USE WITH F16 and F51 ELASTIC CORD

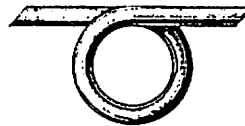

ITEM LETTER	TO SUIT CORD DIA.	WIRE GAUGE
A	$\frac{3}{16}$ "	17 S.W.G.
B	$\frac{1}{4}$ "	16 S.W.G.
C	$\frac{5}{16}$ "	14 S.W.G.
D	$\frac{3}{8}$ "	14 S.W.G.
F	$\frac{1}{2}$ "	12 S.W.G.
G	$\frac{5}{8}$ "	10 S.W.G.

Brown Brothers Engineering Ltd

B.S. SP76 to SP82 SNAP HEAD RIVETS

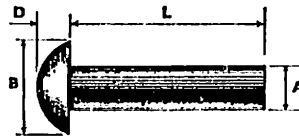

BRITISH STANDARD No.	MATERIAL	SPECIFICATION	TREATMENT	COLOUR	IDENT. MARK
SP 76	Steel	B.S. 1109	Cadmium	—	—
SP 77	Aluminium	L36	Anodic or Chemical Oxidation	Black	I
SP 78	Aluminium Alloy	L37	None	Plain	7
SP 79	Aluminium Alloy	L58	Anodic or Chemical Oxidation	Green	8
SP 80	Aluminium Alloy	L86		Violet	0
SP 81	High Nickel Copper Alloy	D.T.D. 204	None	—	M
SP 82			Cadmium	—	M

NOM. SIZE OF RIVET	A		B		D	
	MAX.	MIN.	MAX.	MIN.	MAX.	MIN.
	IN.	IN.	IN.	IN.	IN.	IN.
$\frac{1}{16}$ "	0.065	0.059	0.114	0.103	0.039	0.035
$\frac{3}{32}$ "	0.097	0.091	0.170	0.157	0.059	0.053
$\frac{1}{8}$ "	0.128	0.122	0.227	0.210	0.079	0.071
$\frac{5}{32}$ "	0.160	0.154	0.282	0.263	0.098	0.090
$\frac{3}{16}$ "	0.191	0.185	0.338	0.317	0.117	0.107
$\frac{7}{32}$ "	0.223	0.215	0.394	0.371	0.136	0.126
$\frac{1}{4}$ "	0.254	0.246	0.450	0.425	0.156	0.144
$\frac{5}{16}$ "	0.316	0.306	0.562	0.531	0.194	0.180
$\frac{3}{8}$ "	0.379	0.367	0.673	0.638	0.233	0.217

METHOD OF ORDERING

Rivets to the above specifications are ordered by the British Standard Number, followed by the part number, the last two figures of the part number denoting the nominal length "L," in $\frac{1}{16}$ of an inch, the remaining figure or figures denoting the diam. in $\frac{1}{32}$ of an inch, e.g. the complete part number for a rivet in L58 material, $\frac{1}{8}$ " diam. and $\frac{3}{8}$ " long, is SP79/410.

Brown Brothers Engineering Ltd

B.S. SP83 to SP85 MUSHROOM HEAD RIVETS

Material : ALUMINIUM ALLOY

BRITISH STANDARD No.	SPECIFICATION	TREATMENT	COLOUR	IDENT. MARK
SP83	L37	None	Plain	7
SP84	L58	Anodic or Chemical Oxidation	Green	8
SP85	L86		Violet	0

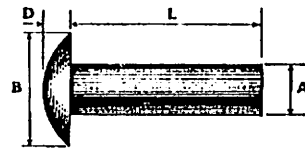

NOM. SIZE OF RIVET	A		B		D	
	MAX.	MIN.	MAX.	MIN.	MAX.	MIN.
$\frac{1}{16}$ "	IN. 0.065	IN. 0.061	IN. 0.130	IN. 0.117	IN. 0.027	IN. 0.023
$\frac{3}{32}$ "	0.097	0.093	0.197	0.178	0.041	0.035
$\frac{1}{8}$ "	0.128	0.124	0.263	0.237	0.054	0.046
$\frac{5}{32}$ "	0.160	0.155	0.325	0.299	0.066	0.058
$\frac{3}{16}$ "	0.191	0.186	0.389	0.359	0.080	0.070
$\frac{7}{32}$ "	0.223	0.218	0.453	0.423	0.093	0.083
$\frac{1}{4}$ "	0.254	0.249	0.517	0.483	0.106	0.094
$\frac{5}{16}$ "	0.316	0.311	0.645	0.603	0.132	0.118
$\frac{3}{8}$ "	0.379	0.374	0.773	0.727	0.158	0.142

BS SP86, SP87 & SP88 100° C'SK PRECISION HEAD RIVETS

BRITISH STD. No.	MATERIAL	SPECIFICATION	FINISH	IDENT. MARK
SP86	Steel	BS1109	Cadmium	---
SP87	Nickel Copper Alloy	D7D204	Self	M
SP88	Nickel Copper Alloy	D7D204	Cadmium	M

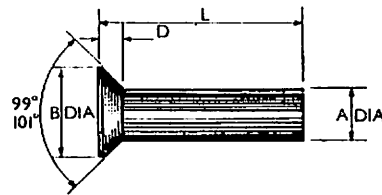

"A" DIA.	$\frac{1}{16}$ "	$\frac{3}{32}$ "	$\frac{1}{8}$ "	$\frac{5}{32}$ "	$\frac{3}{16}$ "	$\frac{1}{4}$ "	$\frac{5}{16}$ "	$\frac{3}{8}$ "
"B" MAX. IN.	0.121	0.172	0.216	0.274	0.337	0.397	0.455	0.535
"B" MIN. IN.	0.111	0.162	0.204	0.262	0.323	0.381	0.439	0.515
"D" DEPTH IN.	0.032	0.041	0.048	0.061	0.078	0.091	0.103	0.115

METHOD OF ORDERING

Rivets to the above specifications are ordered by the British Standard Number, followed by the part number, the last two figures of the part number denoting the nominal length "L" in $\frac{1}{16}$ of an inch, the remaining figure or figures denoting the diameter in $\frac{3}{32}$ of an inch, e.g. the complete part number for a rivet $\frac{1}{8}$ " dia. and $\frac{5}{8}$ " long, in L58 material is SP84/410 and for a steel rivet SP86 /410

Brown Brothers Engineering Ltd

B.S. SP89

AIRFRAME BEARINGS BALL & ROLLER BEARING

This standard acts as a supplement to B.S. 292 and relates to bearings for applications which require features not included in that standard.

B.S. SP90

SPLIT COTTER PINS

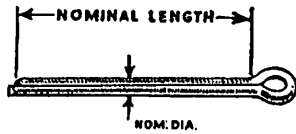

Material: CORROSION RESISTANT STEEL WIRE

ITEM	A	B	C	E	G	H	K	L
Nominal dia.	$\frac{3}{8}$ "	$\frac{1}{2}$ "	$\frac{5}{8}$ "	$\frac{3}{4}$ "	1"	$\frac{3}{4}$ "	$\frac{1}{2}$ "	1"

METHOD OF ORDERING

Part number consists of item letter followed by nominal length in $\frac{1}{8}$ of an inch.

B.S. SP91 & 92

HOSE CLIPS (Worm Drive Type)

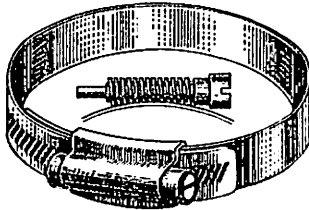

B.S. No.	TYPE OF CLIP	MATERIAL	FINISH
SP91	Clip with band with rolled or milled serrations	Steel	Cadmium
SP92	Clip with band with pierced serrations	Steel	Cadmium

CLIP SIZE	SUITABLE FOR HOSE O/D		CLIP SIZE	SUITABLE FOR HOSE O/D	
	MIN.	MAX.		MIN.	MAX.
A	$\frac{1}{2}$ "	$\frac{3}{4}$ "	J	$1\frac{1}{2}$ "	$2\frac{1}{2}$ "
B	$\frac{3}{4}$ "	1"	K	$1\frac{3}{4}$ "	$2\frac{3}{4}$ "
C	1"	$1\frac{1}{4}$ "	L	2"	$2\frac{3}{4}$ "
D	$1\frac{1}{4}$ "	1 $\frac{3}{4}$ "	M	$2\frac{1}{2}$ "	$3\frac{1}{4}$ "
E	$1\frac{3}{4}$ "	2"	N	$2\frac{3}{4}$ "	$3\frac{1}{2}$ "
F	2"	$2\frac{1}{2}$ "	P	$3\frac{1}{4}$ "	4"
G	$2\frac{1}{4}$ "	$2\frac{3}{4}$ "	Q	$3\frac{3}{4}$ "	4 $\frac{1}{2}$ "
H	$2\frac{3}{4}$ "	3"	R	4 $\frac{1}{4}$ "	5"

Brown Brothers Engineering Ltd

B.S. SP93

Material:
RUBBER (NITRILE)

GROMMETS

This range of grommets is intended for use in engines where resistance to petroleum-based fuels and lubricants is of more importance than the resistance to ozone.
See page 45 for dimensions and method of ordering.

B.S. SP94

BRONZE OIL-RETAINING BUSHES & THRUST WASHERS

This standard covers bushes and thrust washers of the type given in B.S. 1131 Part 5 impregnated with the oil required in bushes for aircraft use.
Details on request

B.S. SP95

Material:
RUBBER (NEOPRENE)

GROMMETS

This range of grommets is intended for use in applications where a good ozone resistance is more important than the resistance to petroleum-based lubricants and fuels.
See page 45 for dimensions and method of ordering

B.S. SP96

INTERNAL RETAINING CLIPS (CIRCLIPS)

Material:
SPRING STEEL
(PHOSPHATE AND OIL)

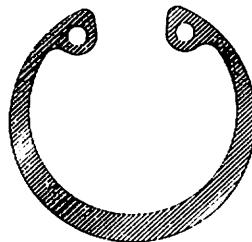

METHOD OF ORDERING

Retaining Rings should be ordered by the specification number followed by the letter "B" and the nominal bore size for which the clip is required.

EXAMPLES:

Metric Retaining Rings: SP96B035M = Retaining Ring to suit 35 m/m nom. dia.
Inch Retaining Rings: SP96B0125 = Retaining Ring to suit 1.250" nom. dia.

Brown Brothers Engineering Ltd

B.S. 2SP101

UNIFIED TURNBARRELS

Material: MILD STEEL (CADMIUM AND TEMPORARY RUST PREVENTATIVE)

B.S. 2SP102 UNIFIED SCREWED ENDS (for Swaged Cable-end Connections)

Material: HIGH TENSILE STEEL (CADMIUM)

(For Tension Rods and Tapped Ends, see B.S. 2SP103 and 2SP104)

(For Turnbarrels and Screwed Ends with BA and BSF Threads, see SP33 and SP34)

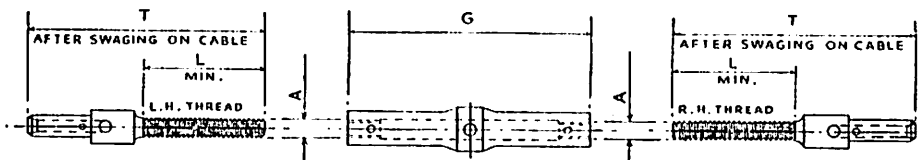

Screwed End (L.H.) B.S. 2SP102

Turnbarrel B.S. 2SP101

Screwed End (R.H.) B.S. 2SP102

CABLE SIZE CWT.	CODE LETTERS	A	L	T
5	C5L	No. 8-32 UNC	IN. 0-85	IN. 1-85
5	D5L	No. 10-32 UNF	1-56	2-56
10	D10L	No. 10-32 UNF	1-56	2-81
15	D15L	No. 10-32 UNF	1-56	2-93
10	E10L	1/4" UNF	1-71	2-90
15	E15L	1/4" UNF	1-71	3-02
20	E20L	1/4" UNF	1-71	3-16
20	G20L	5/16" UNF	1-79	3-26
25	E25L	1/2" UNF	1-71	3-33
25	G25L	5/8" UNF	1-79	3-41
30/35	E30L	1/2" UNF	1-71	3-45
30/35	G35L	3/4" UNF	1-79	3-55
40/45	G45L	7/8" UNF	1-79	3-79

CODE LETTER	A	G
C	No. 8-32 UNC	IN. 1-91
D	No. 10-32 UNF	3-26
E	1/4" UNF	3-36
G	5/16" UNF	3-50

CABLE SIZE CWT.	CODE LETTERS	A	L	T
5	C5	No. 8-32 UNC	IN. 0-85	IN. 1-85
5	D5	No. 10-32 UNF	1-56	2-56
10	D10	No. 10-32 UNF	1-56	2-81
15	D15	No. 10-32 UNF	1-56	2-93
10	E10	1/4" UNF	1-71	2-90
15	E15	1/4" UNF	1-71	3-02
20	E20	1/4" UNF	1-71	3-16
20	G20	5/16" UNF	1-79	3-26
25	E25	1/2" UNF	1-71	3-33
25	G25	5/8" UNF	1-79	3-41
30/35	E30	1/2" UNF	1-71	3-45
30/35	G35	3/4" UNF	1-79	3-55
40/45	G45	7/8" UNF	1-79	3-79

Turnbarrels are ordered by the specification number followed by the code letter of the size required, e.g. a 1/4" UNF turnbarrel would be 2SP101/E.

Screwed ends are ordered by the specification number followed by the code letters of the size required, e.g. a 1/4" UNF (right hand) suitable for a 15 cwt. cable would be 2SP102/E15 and a 5/16" UNF (left hand) suitable for a 20 cwt. cable would be 2SP102/G20L.



Dimensions of Assemblies

CABLE SIZE CWT.	5	5	10	15	10	15	20	20	25	25	30/35	30/35	40/45
THREAD	No. 8-32 UNO	No. 10-32 UNF	No. 10-32 UNF	No. 10-32 UNF	1/4" UNF	1/4" UNF	1/4" UNF	5/16" UNF	1/2" UNF	5/8" UNF	1/2" UNF	5/8" UNF	3/4" UNF
K	MAX. IN.	5-08	7-72	8-22	8-40	8-40	8-64	8-92	9-15	9-26	9-49	9-50	10-21
	MIN. IN.	3-88	5-32	5-82	6-06	6-00	6-24	6-52	6-75	6-86	7-09	7-10	7-81

Brown Brothers Engineering Ltd

B.S. 2SP103

UNIFIED TENSION RODS

Material: HIGH TENSILE STEEL (CADMIUM)

B.S. 2SP104

UNIFIED TAPPED ENDS

(for Swaged Cable-end Connections)

Material: MILD STEEL (CADMIUM AND TEMPORARY RUST PREVENTATIVE)

(For Turnbarrels and Screwed Ends, see B.S. 2SP101 and 2SP102)

(For Tension Rods and Tapped Ends with BA and BSF Threads, see SP35 and SP36)



**Tapped End (L.H.)
B.S. 2SP104**

CABLE SIZE	CODE LETTERS	A	T
CWT. 5	C5L	No. 8-32 UNC	IN. 1.77
5	D5L	No. 10-32 UNF	2.49
10	D10L	No. 10-32 UNF	2.67
15	D15L	No. 10-32 UNF	2.79
10	E10L	1/4" UNF	2.74
15	E15L	1/4" UNF	2.85
20	E20L	1/4" UNF	2.91
20	G20L	5/16" UNF	3.01
25	E25L	1/2" UNF	3.05
25	G25L	5/16" UNF	3.15
30/35	E30L	1/2" UNF	3.17
30/35	G35L	5/16" UNF	3.27
40/45	G45L	5/16" UNF	3.48

Tension Rod (Even Ends) B.S. 2SP103

CODE LETTER	A	B	E
C	No. 8-32 UNC	No. 8-32 UNO	0.85
D	No. 10-32 UNF	No. 10-32 UNF	1.56
E	1/4" UNF	1/4" UNF	1.71
G	5/16" UNF	5/16" UNF	1.79

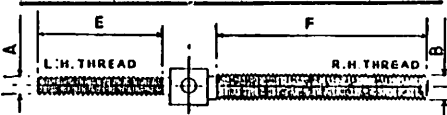

Tension Rod (Odd Ends) B.S. 2SP103

CODE LETTERS	A	B	E	F
CD	No. 8-32 UNC	No. 10-32 UNF	IN. 0.85	IN. 1.56
DC	No. 10-32 UNF	No. 8-32 UNF	1.56	0.85
DE	No. 10-32 UNF	1/4" UNF	1.65	1.71
ED	1/4" UNF	No. 10-32 UNF	1.71	1.65
EG	1/4" UNF	5/16" UNF	1.71	1.79
GE	5/16" UNF	1/4" UNF	1.79	1.71

**Tapped End (R.H.)
B.S. 2SP104**

CABLE SIZE	CODE LETTER	B	T
CWT. 5	C5	No. 8-32 UNO	IN. 1.77
5	D5	No. 10-32 UNF	2.49
10	D10	No. 10-32 UNF	2.67
15	D15	No. 10-32 UNF	2.79
10	E10	1/4" UNF	2.74
15	E15	1/4" UNF	2.85
20	E20	1/4" UNF	2.91
20	G20	5/16" UNF	3.01
25	E25	1/2" UNF	3.05
25	G25	5/16" UNF	3.15
30/35	E30	1/2" UNF	3.17
30/35	G35	5/16" UNF	3.27
40/45	G45	5/16" UNF	3.48

Tension rods are ordered by the specification number followed by the code letter(s) of the size required, e.g. a 1/4" UNF tension rod (even ends) would be 2SP103/E and a 1/4" UNF (left hand) and 2 BA (right hand) tension rod (odd ends) would be 2SP103/EC.

Tapped ends are ordered by the specification number followed by the code letters of the size required, e.g. a 1/4" UNF (right hand) suitable for a 15 cwt. cable would be 2SP104/E15 and a 5/16" UNF (left hand) suitable for a 20 cwt. cable would be 2SP104/G20L.

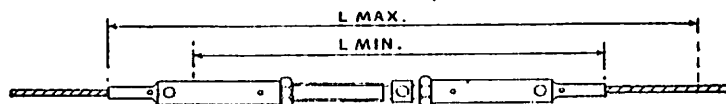

Dimensions of Assemblies

CABLE SIZE CWT.	5	5	10	15	10	15	20	20	25	25	30/35	30/35	40/45
THREAD	No. 8-32 UNC	No. 10-32 UNF	No. 10-32 UNF	No. 10-32 UNF	1/4" UNF	1/4" UNF	1/4" UNF	5/16" UNF	1/2" UNF	5/16" UNF	1/4" UNF	5/16" UNF	5/16" UNF
L	MAX. IN.	5.31	8.04	8.40	8.64	8.72	8.94	9.06	9.35	9.34	9.63	9.58	10.29
	MIN. IN.	4.11	5.64	6.00	6.24	6.32	6.54	6.66	6.95	6.94	7.23	7.18	7.89

Brown Brothers Engineering Ltd

B.S. 2SPI05 SWAGED CABLE END ASSEMBLIES (Unified Threads for Preformed Steel Wire Rope—B.S. W9) Details on request

B.S. 2SPI06 SWAGED CABLE END ASSEMBLIES (Unified Threads for Preformed Non-Corrodible Steel Wire Rope—B.S. W11) Details on request

B.S. SP107 B.S. SP108 UNIFIED STRAIGHT TAB WASHERS (MILD STEEL) (STAINLESS STEEL) (See Page 46)

B.S. SP109 B.S. SP110 UNIFIED RIGHT ANGLE TAB WASHERS (MILD STEEL) (STAINLESS STEEL) (See Page 46)

B.S. SP111 B.S. SP112 UNIFIED LEFT ANGLE TAB WASHERS (MILD STEEL) (STAINLESS STEEL) (See Page 46)

B.S. SP113 SHEAR PINS (CLOSE TOLERANCE)

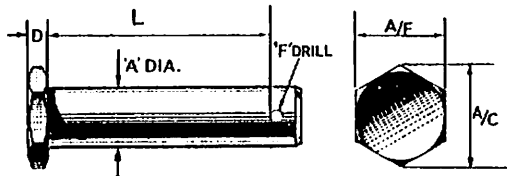

Material :
HIGH TENSILE STEEL
(CADMIUM)

ITEM	NOM. SIZE	A/F		A/C	*A		D		F
		MIN.	MAX.	MAX.	MIN.	MAX.	MIN.	MAX.	DRILL
		IN.	IN.	IN.	IN.	IN.	IN.	IN.	
A	$\frac{1}{8}$ "	0.1890	0.1930	0.220	0.12425	0.12475	0.065	0.070	No. 52
B	$\frac{5}{32}$ "	0.2430	0.2480	0.290	0.15550	0.15600	0.070	0.075	No. 52
C	$\frac{3}{16}$ "	0.2430	0.2480	0.290	0.18075	0.18725	0.075	0.080	No. 52
X	0.1898"	0.3190	0.3240	0.370	0.18905	0.18955	0.075	0.080	No. 52
E	$\frac{1}{4}$ "	0.3700	0.3750	0.433	0.24925	0.24975	0.075	0.085	No. 52
G	$\frac{5}{16}$ "	0.4305	0.4375	0.505	0.31175	0.31225	0.100	0.110	No. 41
J	$\frac{3}{8}$ "	0.4930	0.5000	0.577	0.37425	0.37475	0.100	0.110	No. 30
L	$\frac{7}{16}$ "	0.5545	0.5625	0.650	0.43675	0.43725	0.100	0.110	No. 30
N	$\frac{1}{2}$ "	0.6795	0.6875	0.794	0.49925	0.49975	0.100	0.110	No. 30

* After plating.

METHOD OF ORDERING

The part reference number consists of the item letter followed by the item number which represents the length "L" in $\frac{1}{16}$ of an inch. The complete part number for $\frac{1}{4}$ " nominal diameter shear pin with a length "L" of 0.55" is therefore SP113/E5 $\frac{1}{2}$.

Brown Brothers Engineering Ltd

B.S. SPI14

UNIFIED EYE BOLT

Material :
STEEL (CADMIUM)

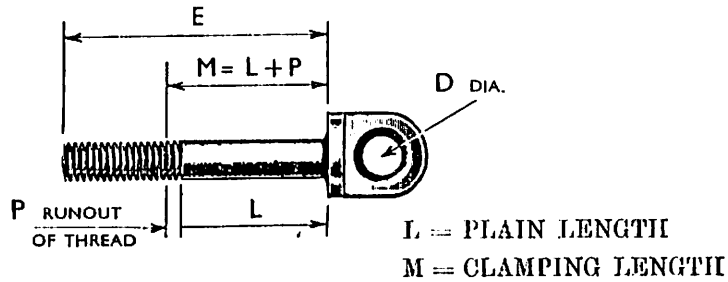

ITEM LETTER	NOM. SIZE	P MAX. 2 × PITCH	E	D	DIA. OF HEAD
C	No. 8-32 UNC	IN. 0.062	IN. M ± 0.358	IN. 0.17	IN. 0.31
D	No. 10-32 UNF	0.062	M ± 0.408	0.22	0.43
E	¼" UNF	0.071	M ± 0.499	0.27	0.56
G	⅝" UNF	0.083	M ± 0.537	0.30	0.62
J	¾" UNF	0.083	M ± 0.637	0.38	0.83

METHOD OF ORDERING

The part reference number consists of the item number which represents the length "L" in $\frac{1}{16}$ of an inch, followed by the item letter representing the size of thread required. The complete part number for a ¼" UNF eye bolt with a length "L" of 1.8" is therefore SP114/18E.

B.S. SPI15, SPI16, SPI17 HYDRAULIC SURFACE CHECK TYPE LUBRICATING NIPPLES

- SP115 ¼" UNF STRAIGHT NIPPLE
- SP116 ¼" UNF 45° ANGLE NIPPLE
- SP117 ¼" UNF 90° ANGLE NIPPLE

B.S. SPI18

UNIFIED TIE RODS

Material : STEEL (CADMIUM)

ITEM	C	D	E	G	J
Nom. Size	No. 8-32 UNC	No. 10-32 UNF	¼" UNF	⅝" UNF	¾" UNF

Brown Brothers Engineering Ltd

BS SPI19 & SPI20 UNIFIED FORK JOINTS

SP119 H.T. STEEL (CADMIUM)

SP120 STAINLESS STEEL

ITEM LETTER		NOMINAL SIZE
R.H.	L.H.	
C	CL	No. 8-32 UNC
D	DL	No. 10-32 UNF
E	EL	$\frac{1}{4}$ " UNF
G	GL	$\frac{5}{16}$ " UNF
J	JL	$\frac{3}{8}$ " UNF

METHOD OF ORDERING

Fork joints to the above specifications are ordered by the British Standard Number, followed by the item letter for the size required. When ordering stainless steel fork joints to SP120, the letter "Z" should precede the item letters, e.g. the complete part number for a left-hand $\frac{1}{4}$ " UNF thread fork joint is SP120/ZEL.

SPI21

COLLARS FOR SHEAR PINS

Material: ALUMINIUM ALLOY (ANODISED & DYED BLUE)

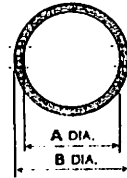

ITEM LETTER	NOM. DIAM.	TO SUIT PIN SPI13	A DIAM.		B DIAM.	C	H	
			MAX.	MIN.			DRILL SIZE	DIAM.
A	$\frac{1}{8}$ "	A	IN. 0.1280	IN. 0.1250	IN. 0.250	IN. 0.220	No. 52	IN. 0.0635
B	$\frac{5}{32}$ "	B	0.1593	0.1563	0.281	0.220	No. 52	0.0635
C	.1898	C & X	0.1928	0.1898	0.313	0.220	No. 52	0.0635
E	$\frac{1}{4}$ "	E	0.2525	0.2500	0.375	0.220	No. 52	0.0635
G	$\frac{5}{16}$ "	G	0.3160	0.3125	0.436	0.250	No. 41	0.0960
J	$\frac{3}{8}$ "	J	0.3785	0.3750	0.500	0.290	No. 30	0.1285
L	$\frac{7}{16}$ "	L	0.4415	0.4375	0.563	0.290	No. 30	0.1285
N	$\frac{1}{2}$ "	N	0.5040	0.5000	0.625	0.290	No. 30	0.1285

METHOD OF ORDERING

Collars to the above specification are ordered by the British Standard Specification Number, followed by the item letter for the nominal diam. required, e.g. the complete part number for a collar for use with a $\frac{1}{4}$ " diam. pin is SP121/E.

Brown Brothers Engineering Ltd

B.S. SPI22, SPI23 & SPI24 WASHERS 18SWG (.048")

B.S. SPI25 WASHERS 12SWG (.104") (Primarily for packing purposes)

B.S. SPI26 & SPI27 WASHERS 26SWG (.018") (Primarily for facing purposes)

SP122 STEEL (CADMIUM)	SP125 ALUMINIUM ALLOY (SELF)
SP123 CORROSION-RESISTING STEEL (SELF)	SP126 STEEL (CADMIUM)
SP124 ALUMINIUM ALLOY (SELF)	SP127 CORROSION RESISTING STEEL (SELF)

ITEM LETTER	TO SUIT BOLTS	DIAM. A		DIAM. B	
		MAX.	MIN.	MAX.	MIN.
A	No. 4-40 UNC	.125	.120	.220	.215
B	No. 6-32 UNC	.151	.146	.295	.290
C	No. 8-32 UNC	.179	.171	.365	.360
D	No. 10-32 UNF	.205	.200	.400	.395
E	1/4" UNF	.270	.265	.515	.505
G	5/16" UNF	.333	.328	.585	.575
J	1/2" UNF	.395	.390	.660	.650
L	3/8" UNF	.458	.453	.805	.795
N	1/2" UNF	.520	.515	.875	.865
P	5/8" UNF	.583	.578	1.020	1.010
Q	1" UNF	.645	.640	1.095	1.085
S	1" UNF	.770	.765	1.235	1.225
U	1" UNF	.895	.890	1.455	1.445
W	1" UNF	1.020	1.015	1.670	1.660

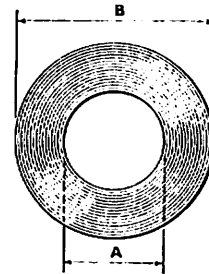

METHOD OF ORDERING

Washers to the above specifications are ordered by the British Standard Number, followed by the item letter indicating the nominal size, e.g. the part number of a thin washer in aluminium alloy to suit a 1/4" UNF bolt is SP124/E.

Brown Brothers Engineering Ltd

B.S. SP. 128—133

WOOD SCREWS

RECESSED HEADS

Superseding SP61-64

<p>90° COUNTERSUNK HEAD</p> <p>SP128 STEEL (CADMIUM)</p> <p>SP130 BRASS (SELF)</p> <p>SP132 STEEL (NICKEL CADMIUM)</p>	<p>Material :</p>	<p>ROUND HEAD</p> <p>SP129 STEEL (CADMIUM)</p> <p>SP131 BRASS (SELF)</p> <p>SP133 STEEL (NICKEL CADMIUM)</p>
--	--------------------------	--

Available in gauge sizes No. 4, 6 and 8 only

B.S. SP. 134-138

CRINKLE WASHERS

Material : BERYLLIUM COPPER

SP134 SELF	SP137 NICKEL COATED
SP135 CADMIUM COATED	SP138 TIN COATED
SP136 SILVER COATED	

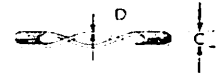
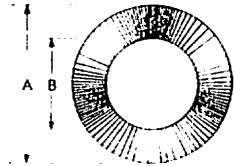

ITEM	TO SUIT SCREW OR BOLT		A DIA.		B DIA.		C	D
	UNIFIED	B.A.	MAX.	MIN.	MAX.	MIN.		
Y	0	10	0.080"	0.075"	0.155"	0.145"	0.017"	0.006"
Z	2	8	0.100"	0.095"	0.211"	0.201"	0.018"	0.006"
A	4	6	0.130"	0.125"	0.255"	0.245"	0.022"	0.006"
B	6	4	0.157"	0.152"	0.305"	0.295"	0.028"	0.008"
C	8	--	0.181"	0.176"	0.345"	0.335"	0.030"	0.011"
D	10	2	0.208"	0.203"	0.380"	0.370"	0.032"	0.012"
E	1"		0.271"	0.260"	0.505"	0.495"	0.042"	0.015"
G	1/8"		0.337"	0.332"	0.605"	0.595"	0.052"	0.015"
J	3/8"		0.411"	0.406"	0.705"	0.695"	0.064"	0.022"
L	1/4"		0.474"	0.469"	0.825"	0.815"	0.070"	0.022"
N	1/2"		0.536"	0.531"	0.955"	0.945"	0.076"	0.022"
Q	3/4"		0.601"	0.596"	1.175"	1.165"	0.090"	0.028"
S	1"		0.786"	0.781"	1.395"	1.385"	0.095"	0.028"

Brown Brothers Engineering Ltd

AGS 113 (B.A.) & 120 (B.S.F.) WING NUTS

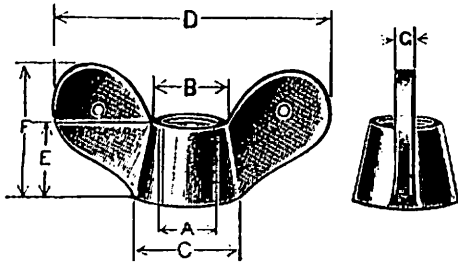

Material : BRASS (CADMIUM)

ITEM NO.	A	B	C	D	E	F	G
A	6 BA	IN. 0.25	IN. 0.28	IN. 1.0	IN. 0.187	IN. 0.50	IN. 0.062
B	4 BA	0.25	0.28	1.0	0.187	0.50	0.062
C	2 BA	0.312	0.34	1.25	0.25	0.625	0.080
A	$\frac{1}{4}$ " BSF	0.375	0.44	1.50	0.31	0.75	0.093
B	$\frac{3}{8}$ " BSF	0.437	0.52	1.62	0.39	0.812	0.093
C	$\frac{1}{2}$ " BSF	0.437	0.52	1.62	0.39	0.812	0.093
D	$\frac{3}{4}$ " BSF	0.50	0.60	1.75	0.47	0.875	0.093
E	$\frac{7}{8}$ " BSF	0.50	0.60	1.75	0.47	0.875	0.093
F	$\frac{1}{2}$ " BSF	0.562	0.71	2.0	0.55	1.00	0.125
G	$\frac{7}{8}$ " BSF	0.562	0.71	2.0	0.55	1.00	0.125
H	1" BSF	0.625	0.82	2.25	0.63	1.125	0.125

AGS 154 WIRE LOCKING RINGS

Material : SPRING STEEL, Japanned all over. Can be supplied in any size to customers' requirements. All orders must state type and dimensions A, B & C and S.W.G.(E).

See also AGS 165.

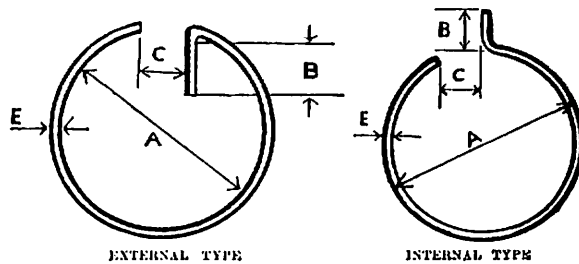

Brown Brothers Engineering Ltd

AGS 162

SINGLE SPRING WASHERS

Replaced by 2SP47.

Material : SPRING STEEL (CADMIUM)

ITEM	NOMINAL SIZE	A	B	C	D
A	6 BA	IN. 0.13	IN. 0.05	IN. 0.125	S.W.G. 18
B	4 BA	0.16	0.06	0.125	18
C	2 BA	0.20	0.06	0.14	16
D	1"	0.27	0.07	0.16	16
E	3/4"	0.33	0.07	0.187	14
F	1/2"	0.39	0.10	0.20	12
G	3/8"	0.46	0.11	0.20	12
H	1/4"	0.52	0.12	0.25	10

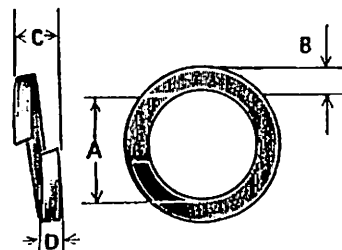

AGS 163

DOUBLE SPRING WASHERS

Material : SPRING STEEL (CADMIUM)

Replaced by SP55.

AGS 164

FIBRE JOINTING WASHERS

Material :
VULCANISED FIBRE

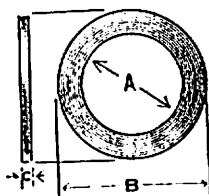

See also AGS 567.

ITEM	A	B	C	ITEM	A	B	C
A	IN. 0.67	IN. 0.94	IN. 0.11	J	IN. 0.925	IN. 1.1	IN. 0.13
B	0.85	1.3	0.13	K	1.9	2.25	0.16
C	1.14	1.5	0.13	L	1.52	1.75	0.16
D	0.53	0.80	0.11	M	0.84	1.12	0.13
E	0.40	0.60	0.08	N	1.2	1.5	0.13
F	0.53	0.71	0.11	P	1.33	1.75	0.16
G	0.84	1.01	0.13	Q	1.67	1.95	0.16
H	1.06	1.3	0.13	R	0.62	0.90	0.11
I	1.39	1.6	0.16	S	0.77	1.05	0.13

Brown Brothers Engineering Ltd

AGS 165

WIRE LOCKING RINGS

Material : SPRING STEEL (JAPANNED)

(See also AGS 154)

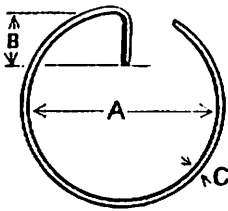

ITEM	A	B	C	ITEM	A	B	C
A	IN. 1.125	IN. 0.2	S.W.G. 14	F	IN. 2.65	IN. 0.25	S.W.G. 16
B	1.0	0.3	16	G	1.4	0.30	18
C	0.75	0.2	16	H	1.45	0.25	18
D	1.95	0.25	16	J	3.15	0.25	18
E	1.84	0.25	16	K	0.85	0.15	18

AGS 207

UNION LOCK NUTS (Steel)

Material: MILD STEEL (CADMIUM)

(See AGS 224 for Brass and AGS 957 for Alum. Alloy, Page 66)

ITEM	A	B	O	D	ITEM	A	B	C	D
A	B.S.P. 1"	IN. 0.525	IN. 0.61	IN. 0.19	E	B.S.P. 1/2"	IN. 1.01	IN. 1.17	IN. 0.19
B	1"	0.60	0.69	0.19	F	1/2"	1.2	1.39	0.19
C	3/4"	0.82	0.95	0.19	G	1"	1.3	1.5	0.19
D	1/2"	0.92	1.06	0.19	H	1"	1.48	1.71	0.19

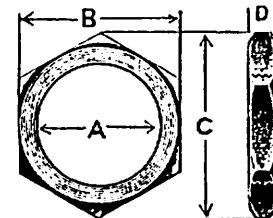

AGS 209

CONICAL NIPPLES

Material: BRASS

(SELF-FINISH)

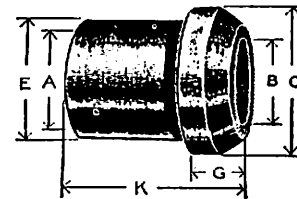

ITEM	A	B	O	B	G	K	NUT	ITEM	A	B	O	B	G	K	NUT
							ITEM								AGS
							1217								1217
O	IN. 1/2	IN. 0.06	IN. 0.33	IN. 0.20	IN. 0.13	IN. 0.38	A	H	IN. 1/2	IN. 0.64	IN. 0.805	IN. 0.72	IN. 0.25	IN. 0.90	E
A	3/8	0.12	0.33	0.25	0.13	0.38	A	J	1/2	0.68	0.91	0.85	0.25	1.04	F
B	1/2	0.18	0.44	0.35	0.15	0.47	B	K	1/2	0.80	1.08	0.98	0.25	1.12	G
BB	1/2	0.24	0.61	0.42	0.17	0.54	BB	L	1	0.93	1.18	1.09	0.30	1.30	H
C	1/2	0.24	0.67	0.42	0.19	0.54	C	M	1 1/2	1.18	1.50	1.38	0.35	1.60	J
D	1/2	0.30	0.67	0.48	0.19	0.59	C	N	1 1/2	1.42	1.75	1.64	0.35	1.85	K
DD	1/2	0.30	0.64	0.52	0.21	0.71	DD	P	1 1/2	1.67	1.99	1.89	0.40	1.95	L
E	1/2	0.36	0.71	0.52	0.23	0.71	D	Q	2	1.92	2.22	2.12	0.45	2.10	M
F	1/2	0.42	0.71	0.60	0.23	0.78	D								

Brown Brothers Engineering Ltd

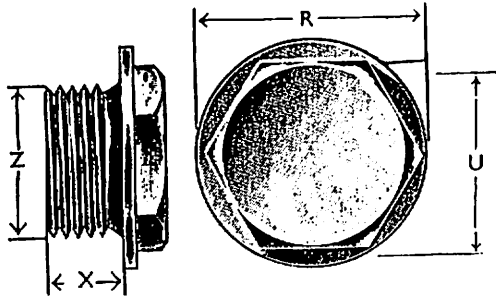

AGS 216 & 948 PLUGS

AGS 216 Material : BRASS (CADMIUM)

**AGS 948 Material : ALUM. ALLOY
(ANODISED)**

(See also AGS 565 & 566)

ITEM	Z	X	U	R	ITEM	Z	X	U	R
A	IN. ½ BSP	IN. 0.3	IN. 0.445	IN. 0.60	L	IN. ½ BSP	IN. 0.42	IN. 1.01	IN. 1.18
B	½ BSP	0.32	0.60	0.75	M	½ BSP	0.46	1.2	1.48
C	½ BSP	0.34	0.71	0.9	N	1 BSP	0.53	1.3	1.6
D	½ BSP	0.41	0.92	1.08	Q	1½ BSP	0.55	1.67	1.95
F	½ BSP	0.43	1.1	1.35	K	1½ BSP	0.59	1.86	2.20

AGS 224 & 957

(BRASS (CADMIUM) (ALUM. ALLOY ANODISED))

UNION LOCK NUTS

(See AGS 207 for Steel)

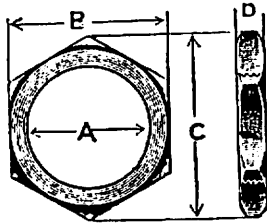

ITEM	A	B	C	D
A	B.S.P. 1"	IN. 0.525	IN. 0.61	IN. 0.19
B	1"	0.60	0.69	0.19
C	1"	0.82	0.95	0.22
D	1"	0.92	1.06	0.25
E	1"	1.1	1.27	0.30

AGS 232

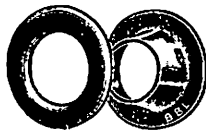

**Material : ALUMINIUM SHEET
(SELF-FINISH)**

OR BRASS
(SELF-FINISH)

Washers also supplied in Leather

ITEM	DIAMETER OF HOLE	
C	½"	} Aluminium
D	1"	
E	½"	} Brass
F	1"	

Brown Brothers Engineering Ltd

AGS 385

BALL JOINTS

Material : Items A & C MILD STEEL
Item B H.T. STEEL
(CADMIUM)

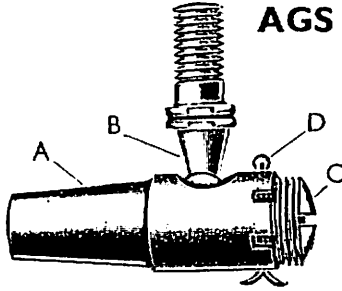

ITEM	SOCKET A	PLUG C	BALL BOLT B	SPLIT PIN D	COMPLETE JOINT A B C D
Socket A, tapped 1/4" B.S.F.			Ball Bolt B, screwed 1/4" B.S.F.		

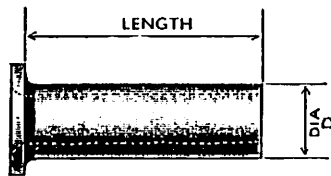

AGS 501 TUBULAR RIVETS

MATERIAL		MIN. ULT. TENSILE STRENGTH	FINISH	IDENTIFICATION
		TONS PER SQ. IN.		
AGS 501A	Aluminium	7	Self	Black Film
AGS 501D	Aluminium Alloy (Duralumin)	25	Self	Natural Colour
AGS 501H	Mild Steel	25	Cadmium	Magnetic Quality
AGS 501J	45% Nickel Alloy	20	Cadmium	
AGS 501K	45% Nickel Alloy	35	Self	Non-Magnetic
		35	Self	Non-Magnetic

OUTSIDE DIAMETER OF TUBE D	S.W.G.	LENGTHS																
		0-25"	0-3"	0-375"	0-5"	0-75"	0-875"	1-0"	1-25"	1-5"	2-0"	2-5"	3-0"	3-5"	4-0"	4-5"	5-0"	5-5"
		ITEM NUMBERS																
3/4"	26	1	—	3	5	7	—	9	—	—	—	—	—	—	—	—	—	—
	22	—	22	—	25	27	—	29	—	—	—	—	—	—	—	—	—	—
1"	26	41	—	43	45	47	—	49	—	—	—	—	—	—	—	—	—	—
	22	—	—	—	65	67	—	69	70	71	73	74	—	—	—	—	—	—
3/4"	22	—	—	—	105	107	108	109	110	111	113	—	—	—	—	—	—	—
	22	—	—	123	125	127	128	129	130	131	133	134	—	—	—	—	—	—
1 1/4"	20	—	—	—	145	147	—	149	150	151	153	154	155	—	—	—	—	—
	17	—	—	—	165	167	—	169	170	171	173	174	175	—	—	—	—	—
1"	22	—	—	183	185	187	—	189	190	191	193	—	—	—	—	—	—	—
	20	—	—	—	205	207	—	209	210	211	213	214	215	—	—	—	—	—
1 1/4"	17	—	—	—	225	227	—	229	230	231	233	234	235	—	—	—	—	—
	20	—	—	—	—	247	—	249	250	251	253	254	255	256	—	—	—	—
1 1/2"	17	—	—	—	—	267	—	269	270	271	273	274	275	276	—	—	—	—
	20	—	—	—	—	287	—	289	290	291	293	294	295	296	297	—	—	—
1"	17	—	—	—	—	307	—	309	310	311	313	314	315	316	317	—	—	—
	17	—	—	—	—	—	—	329	330	331	333	334	335	336	337	338	339	—
1 1/4"	14	—	—	—	—	—	—	349	350	351	353	354	355	356	357	358	359	—
	17	—	—	—	—	—	—	—	370	371	373	374	375	376	377	378	379	380
1 1/2"	14	—	—	—	—	—	—	—	389	391	393	394	395	396	397	398	399	400

Brown Brothers Engineering Ltd.

AGS 565 & 566

PLUGS

AGS 565 Material : BRASS
(CADMIUM)

AGS 566 Material : ALUM. ALLOY
(ANODISED)
(See also AGS 216 and
AGS 1229)

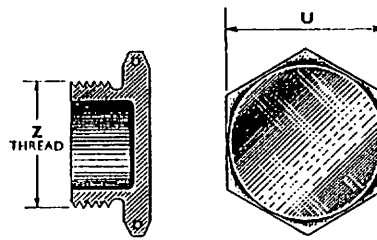

ITEM		A	B	C	D	E	F	G	H	J	K
Z B.S. PIPE		IN. $\frac{1}{8}$	IN. $\frac{1}{4}$	IN. $\frac{3}{8}$	IN. $\frac{1}{2}$	IN. $\frac{5}{8}$	IN. $\frac{3}{4}$	IN. $\frac{7}{8}$	IN. 1	IN. $1\frac{1}{4}$	IN. $1\frac{1}{2}$
U	MAXIMUM	0.600	0.820	0.920	1.100	1.200	1.390	1.480	1.670	2.050	2.220
	MINIMUM	0.595	0.815	0.915	1.092	1.192	1.382	1.468	1.658	2.035	2.200
JOINTING WASHERS AGS 1138 or AGS 1139		A	B	C	D	E	F	G	H	J	K

AGS 567 & 568

JOINTING WASHERS

AGS 567 Material :
VULCANISED FIBRE
(SELF)
(See also AGS 164)

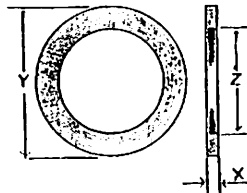

AGS 568 Material :
SOFT ALUMINIUM
(ANODISED)

ITEM	A	B	BB	C	CC	D	E	F	G	H	J	K
AGS 567												
Z	IN. 0.39	IN. 0.52	IN. 0.60	IN. 0.66	IN. 0.75	IN. 0.83	IN. 0.90	IN. 1.04	IN. 1.19	IN. 1.31	IN. 1.65	IN. 1.89
Y	0.60	0.75	0.75	0.90	0.90	1.08	1.18	1.35	1.48	1.60	1.95	2.20
X	0.05	0.05	0.05	0.05	0.07	0.07	0.07	0.07	0.1	0.1	0.1	0.1
AGS 568												
Z	0.39	0.52	0.60	0.66	0.75	0.83	0.90	1.05	1.19	1.31	1.66	—
Y	0.60	0.75	0.75	0.90	0.90	1.08	1.18	1.35	1.48	1.60	1.85	—
X	S.W.G.	18	18	18	18	16	16	16	16	14	14	—
	EQUIVALENT SIZE	0.048	0.048	0.048	0.048	0.064	0.064	0.064	0.064	0.064	0.080	0.080

Brown Brothers Engineering Ltd

AGS 575, 576, 921 & 935 SCREWED RODS

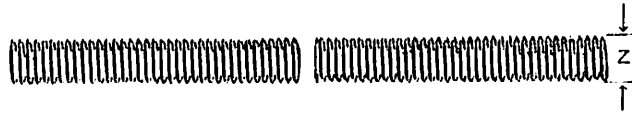

Material :

AGS 575
MILD STEEL
(CADMIUM)

AGS 576
ALUM. ALLOY
(ANODISED)

ITEM	Z
A	6 B.A.
B	4 B.A.
C	2 B.A.
D	$\frac{3}{2}$ " B.S.F.
E	$\frac{1}{4}$ " B.S.F.

Material :

AGS 921
STAINLESS STEEL

AGS 935
H.T. STEEL
(CADMIUM)

AGS 589, 592, 593 ROD END BEARINGS (Internal Thread)

Materials :

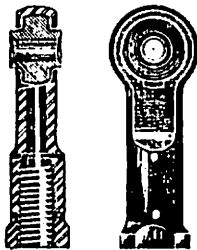

BODIES	Mild Steel (Cadmium)	
BALLS	Mild Steel (Cadmium)	Suffix : S
	Case Hardening Steel (Cadmium)	„ CS
	Phosphor Bronze	„ PB
	Self-lubricating Bronze	„ LB

A $\frac{3}{8}$ " BSF Rod End (Long) with a Right-hand Thread and with a Ball in Mild Steel should be ordered : AGS 592R/S

ITEM	DESCRIPTION	COMPRISING
589R	$\frac{3}{8}$ " BSF Rod End. Short R.H.	AGS 589/1 & 589/3
589L	$\frac{3}{8}$ " BSF Rod End. Short L.H.	AGS 589/2 & 589/3
592R	$\frac{3}{8}$ " BSF Rod End. Long R.H.	AGS 592/1 & 589/3
592L	$\frac{3}{8}$ " BSF Rod End. Long L.H.	AGS 592/2 & 589/3
593R	$\frac{1}{16}$ " BSF Rod End. Short R.H.	AGS 593/1 & 589/3
593L	$\frac{1}{16}$ " BSF Rod End. Short L.H.	AGS 593/2 & 589/3

Brown Brothers Engineering Ltd

AGS 590

ROD END BEARINGS (Plain Shank)

**Material : MILD STEEL,
(CADMIUM)**

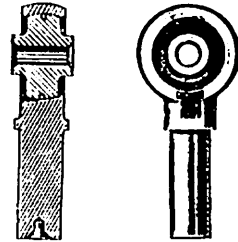

AGS 591 ROD END BEARINGS (External Thread)

Materials:

BODIES	Mild Steel (Cadmium)	
BALLS	Mild Steel (Cadmium)	Suffix : S
	Case Hardening Steel (Cadmium)	.. CS
	Phosphor Bronze	.. PB
	Self-lubricating Bronze	.. LB

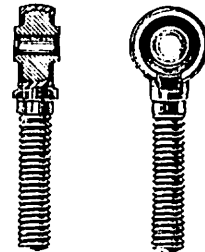

A Rod End with a Ball in Mild Steel should be ordered : AGS 591/S.

$\frac{1}{8}$ " BSF.

ITEM	No.	DESCRIPTION	QUANTITY
1	AGS 591	Body	1
2	AGS 589/3	Ball	1

AGS 592, 593

ROD END BEARINGS

See page 69

AGS 595

PROTECTION PLUG

For Brass Transportation Plugs, see AGS 1229

**Material : BRASS 30 S.W.G. (ELECTRO-TINNED)
OR ALUMINIUM 30 S.W.G. (NATURAL)**

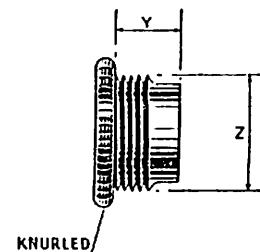

ITEM	A	B	BB	C	CC	D	E	F	G	H	J	K	L	M
Z (BSP)	IN. $\frac{1}{8}$	IN. $\frac{1}{4}$	IN. 0.600 Diam. Whit. form	IN. $\frac{3}{8}$	IN. 0.750 Diam. Whit. form	IN. $\frac{1}{2}$	IN. $\frac{5}{8}$	IN. $\frac{3}{4}$	IN. $\frac{7}{8}$	IN. 1	IN. $1\frac{1}{4}$	IN. $1\frac{1}{2}$	IN. $1\frac{3}{4}$	IN. 2
Y	0.29	0.35	0.38	0.39	0.45	0.48	0.51	0.56	0.66	0.72	0.67	0.77	0.63	0.65

Brown Brothers Engineering Ltd

AGS 596

PROTECTION CAP

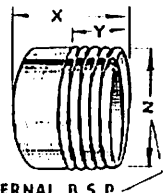

INTERNAL B.S.P.

Material : BRASS or ALUMINIUM 30 SWG

Finishes :
BRASS (ELECTRO-TINNED)
ALUM. (SELF)

ITEM	Z THREAD	X	Y	ITEM	Z THREAD	X	Y
A	IN. $\frac{1}{8}$	IN. 0.58	IN. 0.28	F	IN. $\frac{1}{4}$	IN. 1.00	IN. 0.55
B	$\frac{1}{4}$	0.71	0.45	G	$\frac{3}{8}$	1.00	0.55
BB	0.600	0.75	0.45	H	1	1.00	0.55
C	$\frac{3}{8}$	0.78	0.45	J	1 $\frac{1}{2}$	1.00	0.55
CC	0.750	0.83	0.50	K	1 $\frac{1}{2}$	1.00	0.55
D	$\frac{1}{2}$	0.88	0.55	M	2	—	—
E	$\frac{5}{8}$	0.88	0.55	P	2 $\frac{1}{2}$	—	—

AGS 597

PROTECTION CAP

Material : BRASS OR ALUM. 30 SWG

Finishes : BRASS (ELECTRO-TINNED)
ALUM. (SELF)

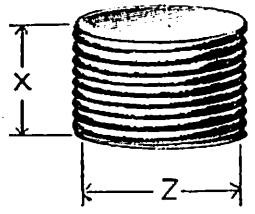

ITEM	INTERNAL THREAD "Z" BSP		X
A	IN. $\frac{1}{8}$	28 TPI	IN. 0.25
B	$\frac{1}{4}$	19 "	0.36
BB	0.600	19 "	0.38
C	$\frac{3}{8}$	19 "	0.38
CC	0.750	14 "	0.44
D	$\frac{1}{2}$	14 "	0.44
E	$\frac{5}{8}$	14 "	0.44
F	$\frac{3}{4}$	14 "	0.48
G	1	14 "	0.48
H	1	11 "	0.50
J	1 $\frac{1}{2}$	11 "	0.50
K	1 $\frac{1}{2}$	11 "	0.63

AGS 605

HOSE CLIPS

Superseded by B.S. SP91 and 92
See Equivalents Chart, page 181

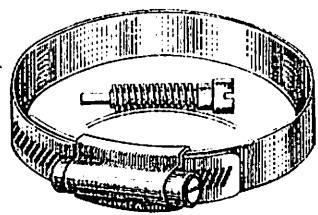

Material : STEEL
(CADMIUM)

ITEM	SUITABLE FOR PIPES O/D		STORES REF. NO.
	MIN.	MAX.	
00	IN. $\frac{1}{8}$	IN. $\frac{1}{4}$	28E/10154
0	$\frac{1}{4}$	$\frac{3}{8}$	28E/8182
1A	$\frac{3}{8}$		
1	$\frac{7}{8}$	1 $\frac{1}{2}$	28E/8183
1X	1	1 $\frac{3}{4}$	
2	1 $\frac{1}{2}$	2	28E/8184
3	2	2 $\frac{1}{2}$	28E/8185
4	2 $\frac{3}{4}$	3 $\frac{1}{2}$	28E/8186
5	3 $\frac{1}{2}$	4 $\frac{1}{2}$	28E/8187
6	4 $\frac{1}{8}$	5	28E/8188

Brown Brothers Engineering Ltd

AGS 606

HOSE CLIPS

ITEM	INSIDE DIAM.	ITEM	INSIDE DIAM.	ITEM	INSIDE DIAM.
A	IN. $\frac{5}{16}$	F	IN. $\frac{5}{8}$	J	IN. $\frac{1}{2}$
B	$\frac{3}{8}$	G	$\frac{3}{4}$	K	$1\frac{1}{8}$
C	$\frac{7}{8}$	H	1	L	1
D	$\frac{1}{2}$	I	$1\frac{1}{2}$	T	$1\frac{1}{2}$
E	$\frac{9}{16}$			V	$1\frac{1}{4}$

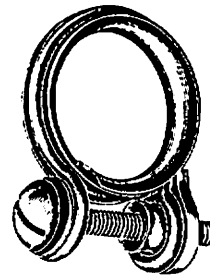

All Steel Parts
Cadmium coated

AGS 607

FILLER CAP

Material : BRASS, GUN-METAL or ALUM. ALLOY

Finishes : BRASS & GUN-METAL
(CADMIUM)

ALUM. ALLOY
(ANODISED)

PART No.	DESCRIPTION
607A B C D	Filler Cap complete with Safety Chain and Plate and Leather Washer
607A	Cap only
607B	Washer
607C	Plate
607D	Chain

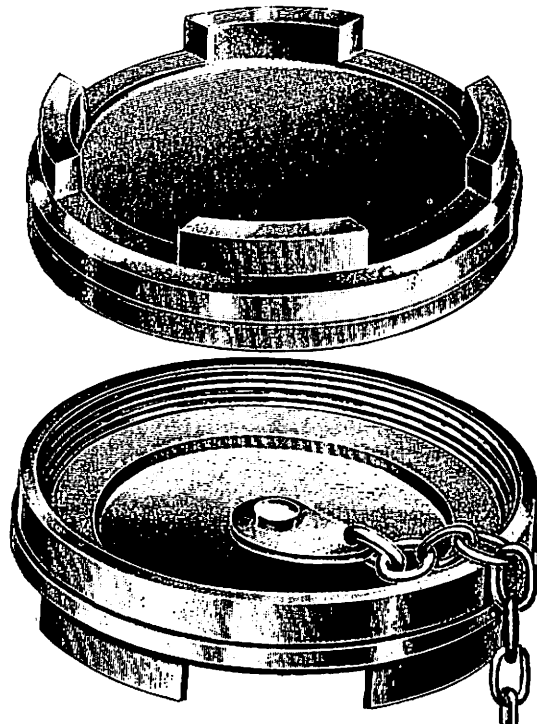

NOTE—Cap is screwed 2.625" dia. × 16
T.P.I. to fit Standard Seatings
AGS 608 and 609

REDUCING UNION BODIES

AGS 626
(BRASS)
(CADMIUM)

AGS 950
(MILD
STEEL)
(CADMIUM)

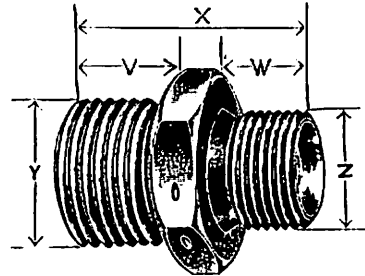

ITEM	THREAD Z	THREAD Y	LENGTH X	LENGTH W	LENGTH V	Hex. A/F MAX.
A	B.S.P. $\frac{1}{4}$ "	B.S.P. $\frac{1}{4}$ "	IN. 1.12	IN. 0.45	IN. 0.45	IN. 0.71
B	$\frac{1}{4}$ "	$\frac{1}{2}$ "	1.17	0.45	0.50	0.82
BB	$\frac{1}{4}$ "	.6" O/D 19 TPI	1.19	0.45	0.52	0.82
C	$\frac{3}{8}$ "	$\frac{1}{2}$ "	1.35	0.50	0.60	1.01
CC	$\frac{3}{8}$ "	.75" O/D 14 TPI	1.30	0.50	0.55	0.92
D	$\frac{1}{2}$ "	$\frac{1}{2}$ "	1.58	0.60	0.70	1.10
E	$\frac{1}{2}$ "	$\frac{3}{4}$ "	1.76	0.70	0.75	1.20
F	$\frac{3}{4}$ "	$\frac{1}{2}$ "	1.90	0.75	0.80	1.39
G	$\frac{3}{4}$ "	1"	1.95	0.80	0.80	1.48
H	1"	1 $\frac{1}{4}$ "	1.95	0.80	0.80	1.86
J	1 $\frac{1}{4}$ "	1 $\frac{1}{4}$ "	2.10	0.80	0.85	2.22

These unions have 60° conical seats to suit standard nipples AGS 209, and AGS 1102

Pipe line fittings and special parts in mild steel, H.T.S., S.S., brass, aluminium and light alloys made to constructors' requirements.

Quotations on receipt of requirements.

Brown Brothers Engineering Ltd

DOUBLE ENDED UNION BODIES

AGS 627
(BRASS)
(CADMIUM)

AGS 949
(MILD
STEEL)
(CADMIUM)

AGS 627 replaced by AGS 949, or AGS 1103

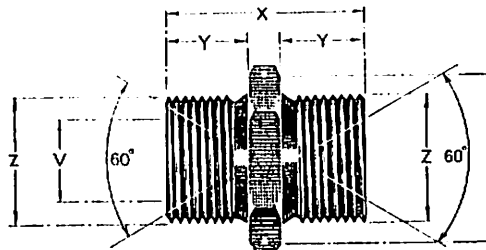

ITEM	THREADS Z	LENGTH Y	LENGTH X	BORE V	HEX. A/P T
	B.S.P.	IN.	IN.	IN.	IN.
A	1"	0.45	1.12	0.187	0.525 0.520
B	1"	0.45	1.12	0.281	0.710 0.705
BB	.6" o/d × 19 TPI	0.52	1.26	0.359	0.820 0.815
C	1.5"	0.50	1.22	0.406	0.820 0.815
CC	.75" o/d × 14 TPI	0.55	1.34	0.468	0.920 0.915
D	1.5"	0.60	1.45	0.531	1.010 1.002
E	2"	0.70	1.68	0.625	1.100 1.092
F	2"	0.75	1.81	0.75	1.200 1.192
G	2.5"	0.80	1.95	0.875	1.390 1.382
H	1"	0.80	1.95	0.968	1.480 1.468
J	1.5"	0.80	1.95	1.25	1.860 1.845
K	1.5"	0.85	2.15	1.468	2.220 2.200
L	1.5"	0.950	2.35	1.687	2.410 2.390
M	2"	1.000	2.50	1.875	2.760 2.735

Brown Brothers Engineering Ltd

AGS 628

REDUCING PLUGS

Material: BRASS (CADMIUM)

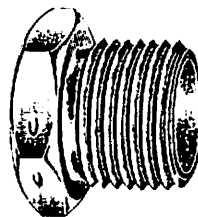

ITEM	SCREWED		LENGTH	HEXAGON A/FLATS
	OUTSIDE	INSIDE		
B	1/2" B.S.P.	1" B.S.P.	IN. 0.85	IN. 1.002 1.010
C	3/8" B.S.P.	1" B.S.P.	0.98	1.002 1.100

AGS 674 & 899

COLLARS

(ALUM. ALLOY) (MILD STEEL)
(ANODISED) (CADMIUM)

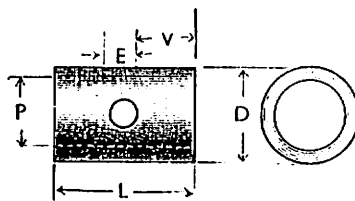

ITEM	P	D	L	V	E	ITEM	P	D	L	V	E
1	IN. 3/32	IN. 3/32	IN. 0.27	IN. 0.1	IN. 0.07	13	IN. 3/32	IN. 1/2	IN. 0.34	IN. 0.1	IN. 0.136
2	1/16	5/16	0.27	0.1	0.07	14	3/8	3/2	0.37	0.1	0.166
3	3/32	1/2	0.27	0.1	0.07	15	1/2	1 1/2	0.37	0.1	0.166
4	1/4	3/4	0.27	0.1	0.07	16	3/4	2	0.37	0.1	0.166
5	5/32	1/2	0.31	0.1	0.104	17	1 1/2	1	0.37	0.1	0.166
6	3/16	3/4	0.31	0.1	0.104	18	1	1 1/2	0.37	0.1	0.166
7	1/2	1	0.31	0.1	0.104	19	1 1/2	1	0.6	0.2	0.199
8	3/4	1 1/2	0.31	0.1	0.104	20	1	1 1/2	0.6	0.2	0.199
9	1 1/2	2	0.34	0.1	0.136	21	1 1/2	1 1/2	0.6	0.2	0.199
10	2	3 1/2	0.34	0.1	0.136	22	1	1 1/2	0.6	0.2	0.199
11	1 1/2	1	0.34	0.1	0.136	23	1 1/2	1 1/2	0.67	0.2	0.261
12	1	3 1/2	0.31	0.1	0.136	--	--	--	--	--	--

Brown Brothers Engineering Ltd

AGS 711, 904 & 954 OUTER SLEEVES

(BRASS (CADMIUM)) (ALUM. ALLOY ANODISED) (MILD STEEL (CADMIUM))

(AGS 711 replaced by AGS 904 or 954)

AGS 904 Item B
cancelled. Replaced
by AGS 2111

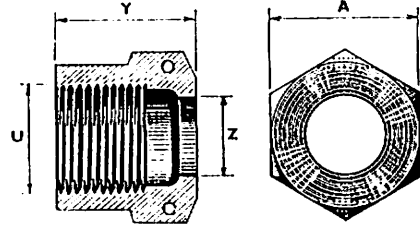

ITEMS A-H MANUFACTURED FROM HEXAGON BAR
ITEMS J-P MANUFACTURED FROM ROUND BAR

ITEM	O/D OF PIPE	U THREAD	AGS 711 & AGS 904		AGS 954		Y	Z DIAM.
			A ACROSS FLATS		A ACROSS FLATS			
			MIN.	MAX.	MIN.	MAX.		
A	$\frac{3}{8}$ "	$\frac{1}{8}$ " BSP	IN. 0.520	IN. 0.525	IN. 0.520	IN. 0.525	IN. 0.63	$\frac{3}{32}$ "
B	$\frac{1}{4}$ "	$\frac{1}{8}$ " BSP	0.595	0.600	0.595	0.600	0.75	$\frac{3}{32}$ "
BB	$\frac{5}{16}$ "	0.600 x 19TPI	0.705	0.710	0.705	0.710	0.80	$\frac{11}{32}$ "
C	$\frac{3}{8}$ "	$\frac{3}{8}$ " BSP	0.815	0.820	0.815	0.820	0.83	$\frac{13}{32}$ "
CC	$\frac{7}{16}$ "	0.75 x 11 TPI	0.915	0.920	0.915	0.920	0.85	$\frac{15}{32}$ "
D	$\frac{1}{2}$ "	$\frac{1}{2}$ " BSP	1.002	1.010	1.002	1.010	0.87	$\frac{17}{32}$ "
E	$\frac{5}{8}$ "	$\frac{5}{8}$ " BSP	1.092	1.100	1.092	1.100	1.01	$\frac{21}{32}$ "
F	$\frac{3}{4}$ "	$\frac{3}{4}$ " BSP	1.192	1.200	1.192	1.200	1.06	$\frac{23}{32}$ "
G	$\frac{7}{8}$ "	$\frac{7}{8}$ " BSP	1.382	1.390	1.292	1.300	1.10	$\frac{27}{32}$ "
H	1"	1" BSP	1.658	1.670	1.468	1.480	1.06	$1\frac{1}{32}$ "
J	1 $\frac{1}{4}$ "	1 $\frac{1}{4}$ " BSP	DIA. 2.110 2.160		DIA. 1.95 1.97		1.06	$1\frac{9}{32}$ "
K	1 $\frac{1}{2}$ "	1 $\frac{1}{2}$ " BSP	DIA. 2.110 2.160		DIA. 2.14 2.16		1.3	$1\frac{17}{32}$ "
M	2"	2" BSP	DIA. 2.940 2.960		---		1.64	$2\frac{1}{32}$ "
P	2 $\frac{1}{2}$ "	2 $\frac{1}{2}$ " BSP	DIA. 3.580 3.600		---		1.86	$2\frac{15}{32}$ "

AGS 771 & 796 to 806 EYEBOLTS

Material : MILD STEEL
(CADMIUM)

Details and Prices on Application

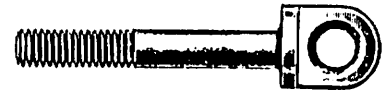

Brown Brothers Engineering Ltd

AGS 772 & 773 PIPE EXPANDING TOOLS

AGS 772 for pipe sizes $\frac{3}{16}$ " to $\frac{1}{2}$ "
 AGS 773 for pipe sizes $\frac{5}{8}$ " to $1\frac{1}{4}$ "

Details and Prices on Application

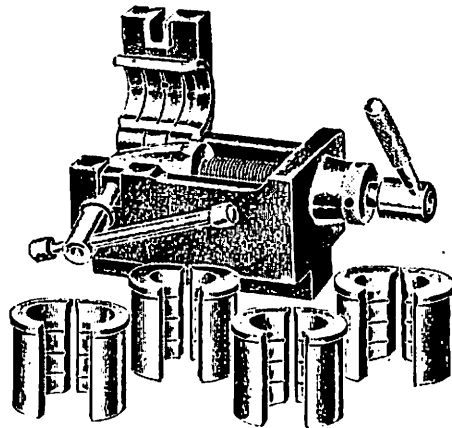

AGS 784 NON-CORRODIBLE SPLIT PINS

Replaced by SP90

See equivalent chart page 182

Material: NON-CORRODIBLE WIRE

AGS 787 SPRING CATCH

Material: BRASS and PHOSPHOR BRONZE (CADMIUM)

Replaced by SP59 (right-hand) and SP 60 (left-hand)

AGS 796 to 806 EYEBOLTS (See AGS 771, page 76)

AGS 838 LOW PRESSURE UNION ASSEMBLIES

For $\frac{5}{16}$ " Tubing. All threads $\frac{1}{2}$ " x 26 TPI Whitform

ALUM. ALLOY ANODISED RUBBER BUSH & WASHER

STRAIGHT UNION	TEE UNION	ELBOW UNION	STRAIGHT OR ELBOW UNION WITH DRAIN TUBE	STRAIGHT OR ELBOW UNION WITH DRAIN TRAP
1 Off Part 1	1 Off Part 2	1 Off Part 3	1 Off Part 2	1 Off Part 2
2 Off Part 13	3 Off Part 13	2 Off Part 13	3 Off Part 4	1 Off Part 6
			3 Off Part 8	1 Off Part 9
			1 Off Part 10	2 Off Part 13

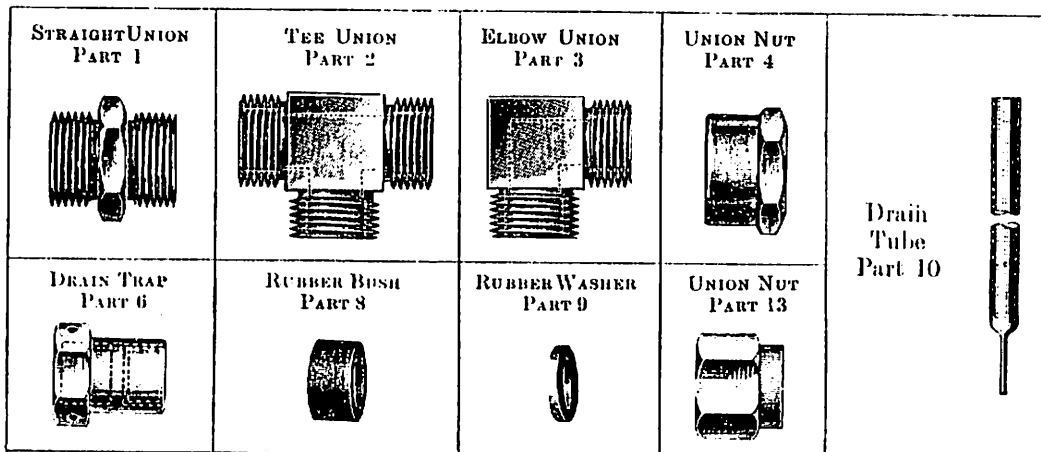

Part 4, Part 8 and Part 10 are obsolescent

Brown Brothers Engineering Ltd

AGS 839 THERMOMETER WASHERS

**Material : COPPER
(CADMIUM)**

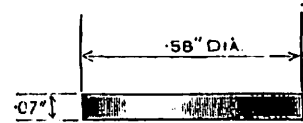
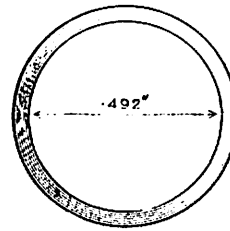

AGS 883 to 887 STUDS

**Material : MILD STEEL
(CADMIUM)**



Details and Prices on Application

AGS 890

LIFTING RING

**Materials : STEEL DROP FORGING (CADMIUM)
or STAINLESS STEEL**

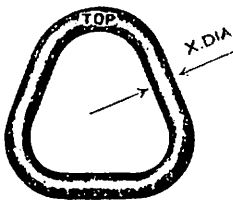

ITEM	'X' DIAMETER		ULTIMATE LOAD (VERTICAL) TONS	PROOF LOAD (VERTICAL) TONS	FOR LOADS UP TO LB.
	MAX.	MIN.			
A	0.430 IN.	0.400 IN.	9	4.5	5000
B	0.530	0.500	16	8	9000

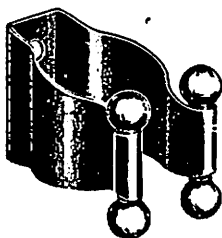

AGS 895 CLIP FOR SPEAKING TUBES

Material : CLIP—SPRING STEEL. ROLLER—MILD STEEL
(Phosphate treatment followed by Stove Enamel)

Brown Brothers Engineering Ltd

AGS 897 HOOK FERRULES FOR ELASTIC CORD

Material: H.T. STEEL WIRE (CADMIUM)
 Replaced by BS. 2SP73 and 2SP74



AGS 899 COLLARS

Material: MILD STEEL (CADMIUM)
 See AGS 674

AGS 900 METAL COUPLINGS (Light Type)

(ALUM. ALLOY)

For use with $\frac{1}{16}$ O/D \times 20 S.W.G. Tube

Material: ALUM. ALLOY

These Couplings are similar to AGS 1101, but of lighter construction, for use on Automatic Controls only.

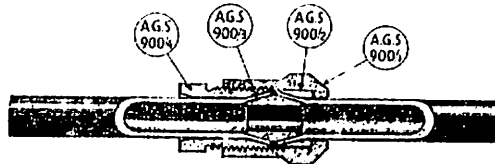
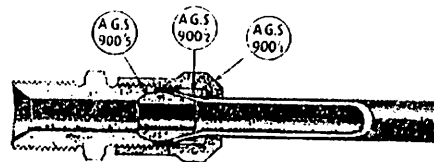

PART	
Outer Sleeves	Part 1
Pipe Collars	Part 2
Nipples	Part 3
Inner Sleeves	Part 4
Adaptor Nipples	Part 5

For PIPE TO PIPE Joints use Parts 1, 2, 3 and 4.

For PIPE TO UNION or similar Fitting use Parts 1, 2 and 5.

Note.—Sleeves, Parts 1 and 4. are screwed $\frac{1}{4}$ " B.S.P.

Brown Brothers Engineering Ltd

PIPE COLLARS

AGS 902 & 952
 (ALUM. ALLOY ANODISED) (STEEL CADMIUM)

AGS 902 replaced by AGS 952

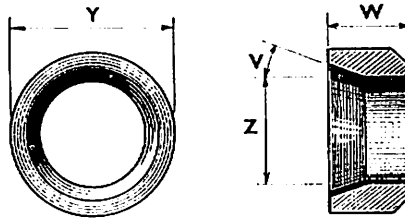

ITEM	O. D. OF PIPE	Z DIAM. BORE	Y	W	V
A	$\frac{3}{16}$ "	$\frac{13}{64}$ "	IN. 0.325	IN. 0.155	$13\frac{1}{2}^\circ$
B	$\frac{1}{4}$ "	$\frac{17}{64}$ "	0.44	0.25	$13\frac{1}{2}^\circ$
BB	$\frac{5}{16}$ "	$\frac{21}{64}$ "	0.523	0.25	$13\frac{1}{2}^\circ$
C	$\frac{3}{8}$ "	$\frac{25}{64}$ "	0.575	0.25	$13\frac{1}{2}^\circ$
CC	$\frac{7}{16}$ "	$\frac{29}{64}$ "	0.65	0.25	$13\frac{1}{2}^\circ$
D	$\frac{1}{2}$ "	$\frac{33}{64}$ "	0.72	0.25	$13\frac{1}{2}^\circ$
E	$\frac{5}{8}$ "	$\frac{41}{64}$ "	0.795	0.25	14°
F	$\frac{3}{4}$ "	$\frac{49}{64}$ "	0.935	0.25	14°
G	$\frac{7}{8}$ "	$\frac{57}{64}$ "	1.085	0.25	14°
H	1"	$1\frac{1}{64}$ "	1.175	0.25	14°
J	$1\frac{1}{4}$ "	$1\frac{17}{64}$ "	1.52	0.30	14°
K	$1\frac{1}{2}$ "	$1\frac{33}{64}$ "	1.75	0.35	$14\frac{1}{2}^\circ$
M	2"	$2\frac{1}{32}$ "	2.22	0.38	15°
P	$2\frac{1}{2}$ "	$2\frac{17}{32}$ "	2.83	0.50	15°

AGS 904

OUTER SLEEVES

See AGS 711

AGS 904 Item B cancelled. Replaced by AGS 2111

Working Pressure: 3000 lb/sq. in. up to $\frac{1}{2}$ " B.S.P.F.
 200 lb/sq. in. $1\frac{1}{4}$ "-2" B.S.P.F.

500 lb/sq. in. up to 1" B.S.P.F.
 100 lb/sq. in. up to $2\frac{1}{2}$ " B.S.P.F.

Brown Brothers Engineering Ltd

AGS 905 & 955 INNER SLEEVES

(ALUM. ALLOY) (STEEL ANODISED) (CADMIUM)

AGS 905 items A-G replaced by AGS 1218

AGS 905 Working Pressure:
500 lb./sq. in. up to 1" B.S.P.F.
200 lb. sq. in. 1 1/2"-2" B.S.P.F.
100 lb. sq. in. up to 2 1/2" B.S.P.F.

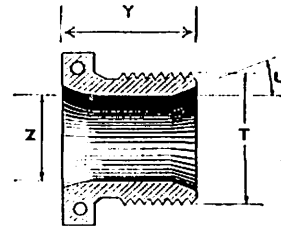
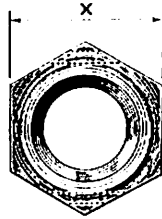

ITEMS A-H FROM HEXAGON BAR

ITEMS J-P FROM ROUND BAR

ITEM	O/D OF PIPE	T THREAD	X ACROSS FLATS		Y	Z	U
			Min.	Max.			
A	3/16"	1/8" BSP	18. 0.440	18. 0.445	18. 0.63	13/64"	13 1/2°
B	1/4"	1/4" BSP	0.520	0.525	0.69	17/64"	13 1/2°
BB	5/16"	0.600 x 19 TPI	0.595	0.600	0.75	11/64"	13 1/2°
C	3/8"	3/8" BSP	0.705	0.710	0.77	25/64"	13 1/2°
CC	7/16"	0.75 x 14 TPI	0.815	0.820	0.81	29/64"	13 1/2°
D	1/2"	1/2" BSP	0.915	0.920	0.83	33/64"	13 1/2°
E	5/8"	5/8" BSP	1.002	1.010	0.89	41/64"	14°
F	3/4"	3/4" BSP	1.092	1.100	0.94	49/64"	14°
G	7/8"	7/8" BSP	1.292	1.300	0.98	57/64"	14°
H	1"	1" BSP	1.382	1.390	0.98	1 1/64"	14°
Dia.							
J	1 1/4"	1 1/4" BSP	1.95	1.97	1.00	1 17/64"	14°
K	1 1/2"	1 1/2" BSP	2.14	2.16	1.15	1 33/64"	14 1/2°
M	2"	2" BSP	2.94	2.96	1.39	2 1/32"	15°
P	2 1/2"	2 1/2" BSP	3.58	3.60	1.49	2 17/32"	15°

AGS 910

LUBRICATION NIPPLE

Material : STAINLESS STEEL or MILD STEEL (CADMIUM)

A	B	C
1/8" B.S.P.	0.441" 0.445"	0.15"
1/4" B.S.F.	0.278" 0.282"	0.10"

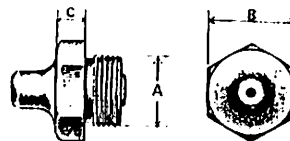

Brown Brothers Engineering Ltd

CHAIN SHACKLES AND PINS

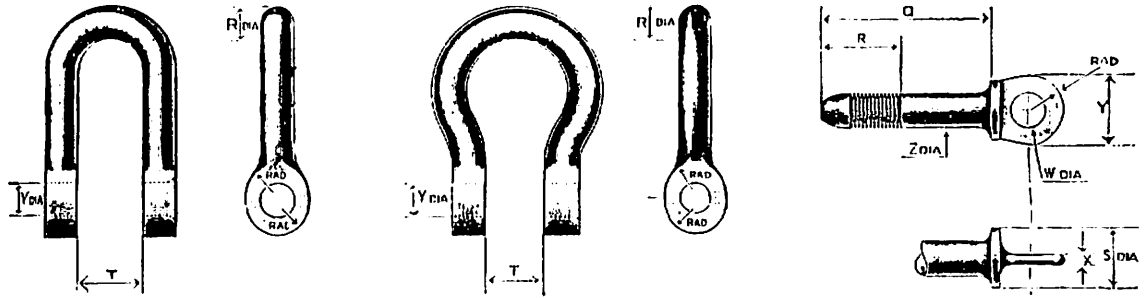

AGS 911 CHAIN SHACKLES FOR ANCHOR CABLES

Complete assembly

AGS 912 SHACKLES ("U" SHAPE)

Material : STEEL (CADMIUM)

ITEM	NOMINAL SIZE OF SHACKLE	Y	T	R	PROOF LOAD	CHAIN FOR WHICH SUITABLE
C	1"	1" BSF	0.72"	0.36"	LB. 2,100	1"
D	1 1/2"	1 1/2" BSF	0.81"	0.42"	2,860	1 1/2"
E	2"	2" BSF	1.00"	0.48"	3,730	2"
F	3"	3" BSF	1.20"	0.60"	5,830	3"
G	4"	4" BSF	1.50"	0.72"	8,400	4"

AGS 914 SHACKLES (HARP SHAPE)

Material : STEEL (CADMIUM)

ITEM	NOMINAL SIZE OF SHACKLE	Y	T	R	PROOF LOAD	CHAIN FOR WHICH SUITABLE
C	1"	1" BSF	0.72"	0.36"	LB. 2,100	1"
D	1 1/2"	1 1/2" BSF	0.81"	0.42"	2,860	1 1/2"
E	2"	2" BSF	1.00"	0.48"	3,730	2"
F	3"	3" BSF	1.20"	0.60"	5,830	3"
G	4"	4" BSF	1.50"	0.72"	8,400	4"

AGS 916 SHACKLE PINS

Material : STEEL (CADMIUM)

ITEM	NOMINAL SIZE OF PIN	% DIA. & THREAD	Y	X	W	S	R	Q	PROOF LOAD	CHAIN FOR WHICH SUITABLE
C	1"	1" BSF	0.78"	0.12"	1"	0.66"	0.90"	1.92"	LB. 2,100	1"
D	1 1/2"	1 1/2" BSF	0.91"	0.14"	1 1/2"	0.77"	1.05"	2.24"	2,860	1 1/2"
E	2"	2" BSF	1.04"	0.16"	2"	0.88"	1.20"	2.60"	3,730	2"
F	3"	3" BSF	1.30"	0.20"	3"	1.10"	1.50"	3.20"	5,830	3"
G	4"	4" BSF	1.56"	0.24"	4"	1.32"	1.80"	3.90"	8,400	4"

Brown Brothers Engineering Ltd

AGS 918 END LINK FOR CHAIN SHACKLE

Material : STEEL (CADMIUM)

ITEM	NOMINAL SIZE OF CHAIN	Z	Y	X	PROOF LOAD FOR W.L. CHAIN	SIZE OF SUITABLE SHACKLE FOR W.L. CHAIN
	IN.	IN.	IN.	IN.	LBS.	IN.
C	$\frac{1}{4}$	1.44	0.48	0.32	1,680	$\frac{1}{2}$
D	$\frac{3}{16}$	1.80	0.60	0.40	2,625	$\frac{7}{16}$
E	$\frac{1}{2}$	2.16	0.72	0.48	3,780	$\frac{1}{2}$
F	$\frac{7}{16}$	2.52	0.84	0.56	5,145	$\frac{3}{4}$
G	$\frac{1}{2}$	2.88	0.96	0.64	6,720	$\frac{3}{4}$

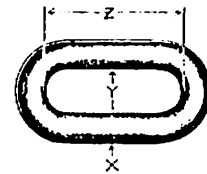

AGS 920 & 934 FERRULES

AGS 920 Material : STAINLESS STEEL

AGS 934 Material : I.I.T. STEEL
(CADMIUM)

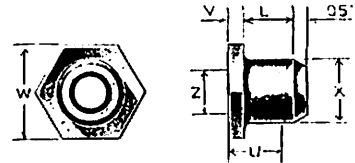

SIZE X		ITEM	L	Z	W	V	U
NOMINAL	LIMITS						
IN.	IN.		IN.		IN.	IN.	IN.
$\frac{1}{8}$	0.1855	CL	0.35	6 BA	0.245	0.05	0.15
	0.1865	CM	0.25		0.248		
		CS	0.15				
$\frac{1}{4}$	0.2167	DL	0.40	4 BA	0.321	0.07	0.20
	0.2177	DM	0.30		0.324		
		DS	0.20				
$\frac{3}{8}$	0.2480	EL	0.45	4 BA	0.321	0.07	0.20
	0.2490	EM	0.35		0.324		
		ES	0.20				
$\frac{1}{2}$	0.2792	FL	0.50	2 BA	0.410	0.07	0.25
	0.2802	FM	0.40		0.413		
		FS	0.25				
$\frac{5}{8}$	0.3105	GL	0.55	2 BA	0.440	0.07	0.25
	0.3115	GM	0.40		0.445		
		GS	0.25				
$\frac{3}{4}$	0.3730	JL	0.65	$\frac{3}{4}$ " BSF	0.520	0.07	0.28
	0.3740	JM	0.50		0.525		
		JS	0.30				
$\frac{7}{8}$	0.4355	LL	0.80	$\frac{7}{8}$ " BSF	0.595	0.08	0.28
	0.4365	LM	0.60		0.600		
		LS	0.35				
1	0.4980	NL	0.90	1 " BSF	0.595	0.08	0.30
	0.4990	NM	0.65		0.600		
		NS	0.40				

AGS 921 & 935

SCREWED RODS

(See Page 69)

AGS 948

PLUGS

(See page 66)

AGS 949 & 950

UNION BODIES

(See AGS 627 & 626)

AGS 950 Working Pressure:
 3000 lb/sq. in. up to 1/2" B.S.P.F.
 500 lb/sq. in. 1/2"-3/4" B.S.P.F.
 200 lb/sq. in. 1" & 1 1/4" B.S.P.F.

AGS 952

PIPE COLLARS

(See AGS 902)

AGS 954 & 955 OUTER & INNER SLEEVES

(See AGS 711 and AGS 905)

AGS 954 & 955 Working Pressure:
 3000 lb/sq. in. up to 1/2" B.S.P.F.
 500 lb/sq. in. 5/8"-1" B.S.P.F.
 200 lb/sq. in. 1 1/4" & 1 1/2" B.S.P.F.

AGS 957

LOCK NUTS (ALUM. ALLOY)

(See AGS 221)

AGS 958

(ALUM. ALLOY)
(ANODISED)

FEMALE FLANGES

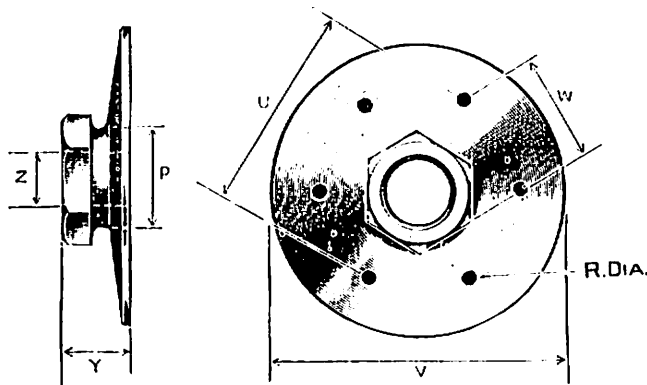

ITEM	Z BSP	DEPTH Y	HEX. A/P W	FLANGE DIAM. V	PITCH CIRCLE DIAM. U	DIAM. P	DIAM. R
A	1"	0.32	0.525	1.42	1.025	0.50	1.5
B	1"	0.35	0.710	1.50	1.10	0.585	1.5
C	1"	0.45	0.820	1.70	1.30	0.74	1.5
D	1"	0.55	1.010	1.90	1.50	0.99	1.5
E	1"	0.65	1.100	2.0	1.60	1.06	1.5
F	1"	0.65	1.200	2.10	1.70	1.18	1.5
G	1"	0.67	1.300	2.25	1.85	1.31	1.5
H	1"	0.70	1.480	2.35	1.95	1.46	1.5
J	1 1/4"	0.80	1.860	2.75	2.35	1.80	1.5

Brown Brothers Engineering Ltd

AGS 959
(ALUM. ALLOY)
(ANODISED)

SPECIAL FEMALE FLANGES

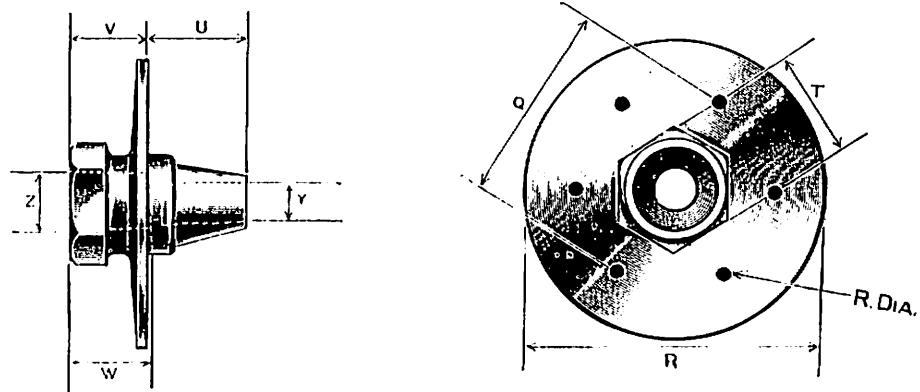

ITEM	THREADS Z	DEPTH U	DEPTH V	DEPTH W	HExAGON A/FLATS T	P.C.D. Q	FLANGE R	BORE Y	DIAM. R
		IN.	IN.	IN.	IN.	IN.	IN.	IN.	IN.
B	1/2" BSP	0.50	0.35	0.40	0.705/0.71	1.10	1.50	0.25	7/64
C	3/8" BSP	0.52	0.45	0.50	0.815/0.820	1.30	1.70	0.375	7/64
D	1/2" BSP	0.65	0.55	0.62	1.002/1.010	1.50	1.90	0.50	7/64
E	3/4" BSP	0.79	0.65	0.72	1.092/1.10	1.60	2.0	0.625	7/64
F	1/2" BSP	0.95	0.65	0.75	1.192/1.20	1.70	2.10	0.75	7/64
G	3/4" BSP	1.07	0.67	0.77	1.382/1.39	1.85	2.25	0.875	7/64
H	1" BSP	1.20	0.70	0.80	1.468/1.48	1.95	2.35	1.0	7/64
J	1 1/2" BSP	1.45	0.80	0.90	1.845/1.86	2.35	2.75	1.25	7/64

Brown Brothers Engineering Ltd

AGS 977, 978 & 979
 (ALUM. ALLOY) (STEEL) (BRASS)
 (ANODISED) (CADMIUM) (CADMIUM)

MALE FLANGES (BOLTED)

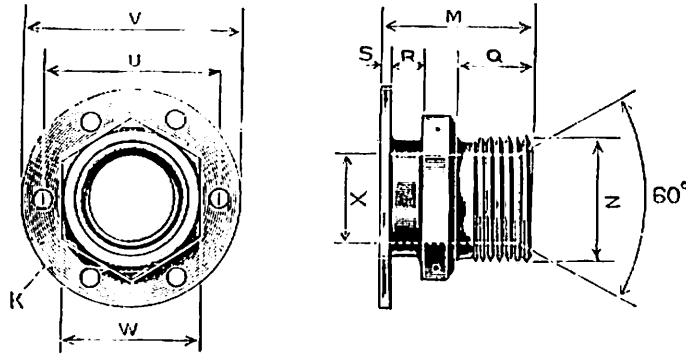

ITEM	Z	X	W		V	U	M	S	R	Q	K
	B.S.P. Thread	Bore	Min.	Max.							Dia. Drill
A	1/4	1/8	0.520	0.525	1.42	1.025	1.03	0.080	0.35	0.45	1/8
B	1/4	1/8	0.705	0.710	1.50	1.10	1.06	0.080	0.35	0.45	1/8
BB	0.60 O/D 10 T.P.I.	1/8	0.760	0.765	1.60	1.20	1.15	0.080	0.35	0.52	1/8
C	1/4	1/8	0.815	0.820	1.70	1.30	1.20	0.080	0.35	0.55	1/8
CC	0.75 O/D 14 T.P.I.	1/8	0.915	0.920	1.80	1.40	1.22	0.080	0.35	0.55	1/8
D	1/4	1/8	1.002	1.010	1.90	1.50	1.28	0.080	0.35	0.60	1/8
E	1/4	3/16	1.082	1.100	2.00	1.60	1.41	0.080	0.35	0.70	1/8
F	1/4	1/8	1.182	1.200	2.10	1.70	1.49	0.080	0.35	0.75	1/8
G	1/4	1/8	1.382	1.390	2.25	1.85	1.56	0.080	0.35	0.80	No. 48
H	1/4	1/8	1.468	1.480	2.35	1.95	1.58	0.080	0.35	0.80	No. 48
J	3/8	1/4	1.845	1.860	2.75	2.35	1.61	0.080	0.35	0.80	No. 48
K	1/2	1/2	2.200	2.220	3.15	2.70	1.68	0.080	0.35	0.85	No. 48

Brown Brothers Engineering Ltd

AGS 980, 981 & 982
 (ALUM. ALLOY) (MILD STEEL) (BRASS)
 (ANODISED) (CADMIUM) (CADMIUM)

FEMALE FLANGES (BOLTED)

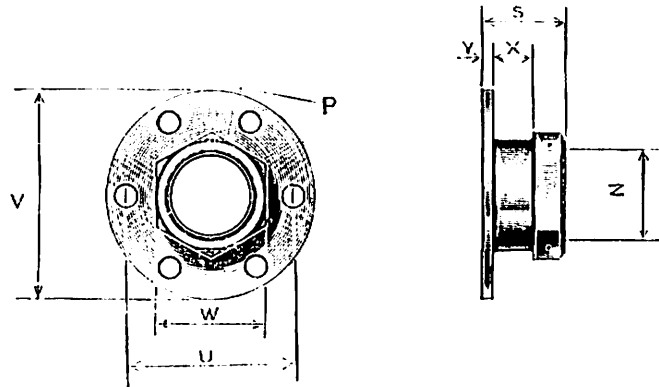

ITEM	Z B.S.P. Thread	W		V	U	S	P	Y	X
		Min.	Max.				Dia. Drill		
A	1/8 IN.	0.520 IN.	0.525 IN.	1.42 IN.	1.025 IN.	0.60 IN.	1/8 IN.	0.080 IN.	0.35 IN.
B	1/4	0.705	0.710	1.50	1.10	0.60	1/8	0.080	0.35
BB	19 T.P.I. Whit. Form 0.60 O/D	0.760	0.765	1.60	1.20	0.67	1/8	0.080	0.35
C	3/8	0.815	0.820	1.70	1.30	0.67	1/8	0.080	0.35
CC	14 T.P.I. Whit. Form 0.75 O/D	0.915	0.920	1.80	1.40	0.70	1/8	0.080	0.35
D	1/2	1.002	1.010	1.90	1.50	0.75	1/8	0.080	0.40
E	5/8	1.092	1.100	2.00	1.60	0.85	1/8	0.080	0.45
F	3/4	1.192	1.200	2.10	1.70	0.90	1/8	0.080	0.50
G	7/8	1.382	1.390	2.25	1.85	0.95	No. 48	0.080	0.50
H	1	1.468	1.480	2.35	1.95	0.95	No. 48	0.080	0.50
J	1 1/4	1.845	1.860	2.75	2.35	0.95	No. 48	0.080	0.50
K	1 1/2	2.200	2.220	3.15	2.70	1.00	No. 48	0.080	0.50

Brown Brothers Engineering Ltd

AGS 986, 987 & 988

(ALUM. ALLOY) (MILD STEEL) (BRASS)
(ANODISED) (CADMIUM) (CADMIUM)

FEMALE FLANGES (BOLTED) WITH SPIGOT

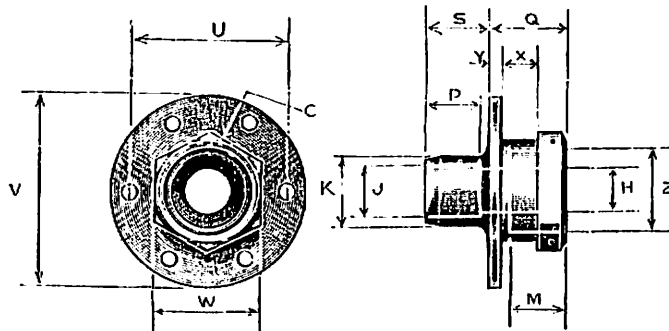

ITRM	Z	W		V	U	S	Q	K	J	H	C	M	P	Y	X
	B.S.P. Thread	Min.	Max.							Dia. Drill	Dia. Drill				
A	1/4	0.520	0.525	1.42	1.025	0.50	0.60	0.34	0.187	1/8	1/8	0.47	0.40	0.08	0.35
B	3/8	0.705	0.710	1.50	1.10	0.50	0.60	0.40	0.260	3/16	3/16	0.47	0.40	0.08	0.35
BB	19 T.P.I. Whit. Form 0.60 O/D	0.760	0.765	1.60	1.20	0.50	0.67	0.47	0.312	1/4	3/8	0.54	0.40	0.08	0.35
C	1/2	0.815	0.820	1.70	1.30	0.52	0.67	0.53	0.375	1/4	3/8	0.54	0.42	0.08	0.35
CC	11 T.P.I. Whit. Form 0.75 O/D	0.915	0.920	1.80	1.40	0.58	0.70	0.59	0.437	1/2	3/8	0.57	0.46	0.08	0.35
D	5/8	1.002	1.010	1.90	1.50	0.65	0.75	0.66	0.500	3/8	3/8	0.62	0.53	0.08	0.40
E	3/4	1.092	1.100	2.00	1.60	0.79	0.85	0.78	0.625	1/2	3/4	0.72	0.67	0.08	0.45
F	7/8	1.192	1.200	2.10	1.70	0.95	0.90	0.90	0.750	5/8	3/4	0.77	0.80	0.08	0.50
G	1	1.382	1.390	2.25	1.85	1.07	0.95	1.03	0.875	3/4	No. 48	0.82	0.92	0.08	0.50
H	1 1/8	1.468	1.480	2.35	1.95	1.20	0.95	1.16	1.000	7/8	No. 48	0.82	1.05	0.08	0.50
J	1 1/4	1.815	1.860	2.75	2.35	1.45	0.95	1.41	1.250	1 1/8	No. 48	0.82	1.30	0.08	0.50
K	1 1/2	2.200	2.220	3.15	2.70	1.60	1.00	1.66	1.500	1 1/4	No. 48	0.87	1.55	0.08	0.50

Brown Brothers Engineering Ltd

AGS 995 to AGS 998 HIGH DUTY STUDS



Material : H.T. STEEL
(CADMIUM)

SIZE	ITEM	LENGTH OF THREAD B	DIAMETER C
2BA	AGS 995	0.375	0.175/0.178
$\frac{1}{4}$ " BSF	AGS 996	0.500	0.2412/0.2442
$\frac{5}{16}$ " BSF	AGS 997	0.625	0.3027/0.3057
$\frac{3}{8}$ " BSF	AGS 998	0.750	0.3645/0.3675

METHOD OF ORDERING

Method of calling up is by AGS number followed by "A" length in tenths of an inch. *E.g.* a 2 BA stud "A" length 2.6" is AGS 995/26, and a $\frac{5}{16}$ " BSF stud "A" length 3.8" is AGS 997/38.

AGS 1000

HOSE CLIPS

Replaced by SP91 and 92

Material: STEEL (CADMIUM)

See Equivalents Chart, page 181

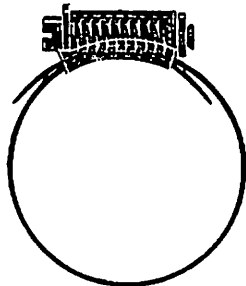

SUITABLE FOR HOSE O/D

ITEM	MIN.	MAX.	ITEM	MIN.	MAX.
00A & 00	IN. $\frac{1}{2}$	IN. $\frac{5}{8}$	3	IN. Over 2	IN. $2\frac{1}{2}$
0	Over $\frac{5}{8}$	$\frac{3}{4}$	4	Over $2\frac{1}{2}$	$3\frac{1}{2}$
1A	Over $\frac{3}{4}$	Up to and inc. $1\frac{1}{8}$	5	Over $3\frac{1}{2}$	$4\frac{1}{2}$
1	Over $\frac{3}{4}$	Up to and inc. $1\frac{1}{2}$	6	Over $4\frac{1}{2}$	5
1X	1	$1\frac{1}{8}$			
2	Over $1\frac{1}{2}$	2			

Brown Brothers Engineering Ltd

AGS 1101

PIPE COUPLINGS: GENERAL ARRANGEMENT

END OF GANE
UNION BODY
CORNER ELBOW, ETC.
OR INTEGRAL
UNION OF
COMPONENT

END OF UNION
BODY ELBOW
TEE, ETC. FOR
INTEGRATION
OF COMPONENT

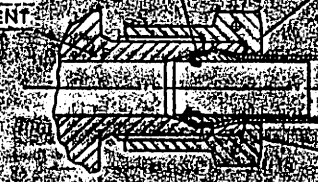
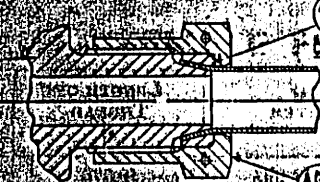

1. STANDARD JOINT FOR ALL
PIPES UP TO 1/2"

2. PIPE TO FITTING JOINT, SIZES 1/2" AND ABOVE
This type of joint can also be used for sizes 1/2" to 1" when
connections is required to be made to a component not
provided with the standard solid cone end.

INNER SLEEVE (AGS 905) NIPPLE TO COLLAR (AGS 1170) OUTER SLEEVE (AGS 904/954)

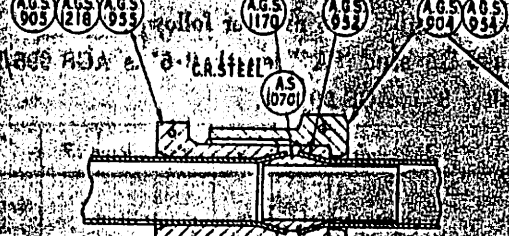

3. PIPE TO PIPE JOINT, SIZES 1/2" AND ABOVE
This type of joint can also be used for sizes 1/2" to 1" when
space considerations preclude the use of the
arrangement shown in figure 2.

END OF UNION
BODY ELBOW, TEE,
Etc. OR
INTEGRATION
OF COMPONENT

END FITTINGS
OF TYPICAL APPROVED
HOSE ASSEMBLY

COMPONENT TAPPED
TO ACCOMMODATE
AGS 1104 OR
AGS 1105

UNION BAPTOR

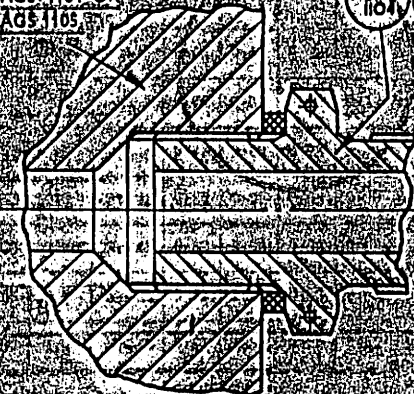
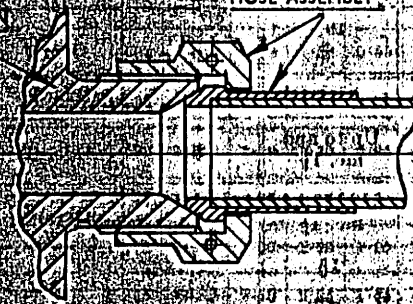

A. HOSE ASSEMBLY TO FITTING, ALL SIZES

B. PIPE TO COMPONENT, ALL SIZES

AGS. 1101

PIPE COUPLINGS: GENERAL ARRANGEMENT

END OF CONE
UNION BODY
CONE ELBOW, ETC.
OR INTEGRAL
UNION OF
COMPONENT

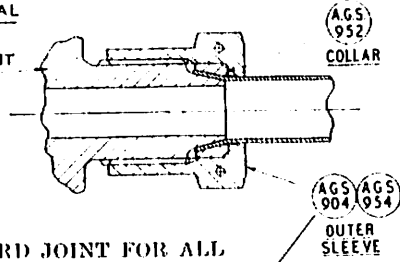

1. STANDARD JOINT FOR ALL PIPES UP TO 1/2"

AGS 2111 for 1/2" dia. pipe

END OF UNION
BODY ELBOW
TEE, ETC. FOR
INTEGRAL UNION
OF COMPONENT

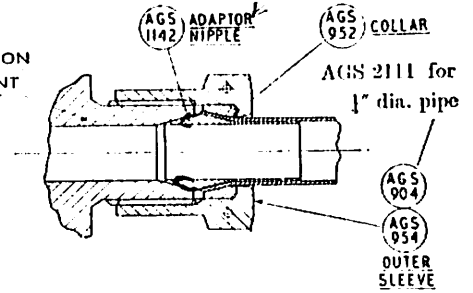

2. PIPE TO FITTING JOINT, SIZES 3/8" AND ABOVE

This type of joint can also be used for sizes 3/16" to 1/2" when connection is required to be made to a component not provided with the standard solid cone end.

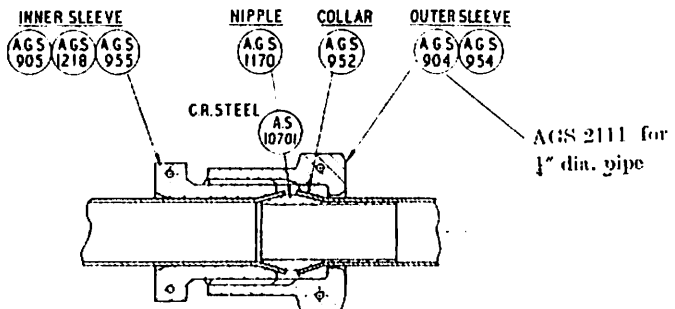

3. PIPE TO PIPE JOINT, SIZES 3/8" AND ABOVE

This type of joint can also be used for sizes 3/16" to 1/2" when space considerations preclude the use of the arrangement shown in Fig. 1

END OF UNION
BODY, ELBOW, TEE,
ETC., OR
INTEGRAL UNION
OF COMPONENT

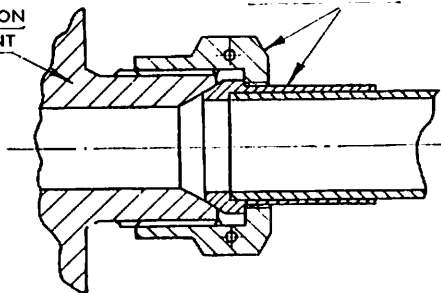

4. HOSE ASSEMBLY TO FITTING, ALL SIZES

COMPONENT TAPPED
TO ACCOMMODATE
AGS 1104 OR
AGS 1105

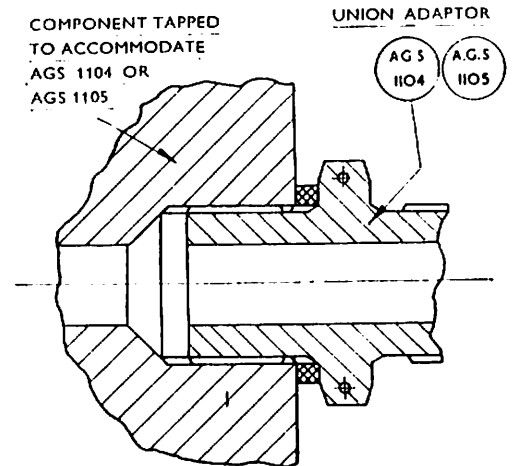

5. PIPE TO COMPONENT, ALL SIZES

Brown Brothers Engineering Ltd

AGS 1102

CONE UNION BODY

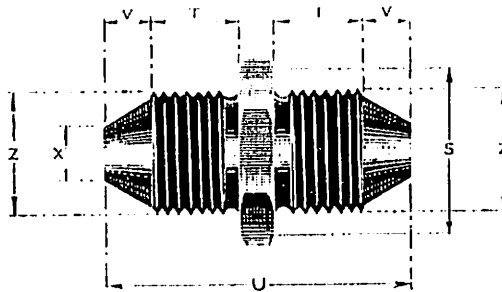

Material : ALUM. ALLOY (ANODISED)

Working Pressure : 3000 lb./sq. in. for sizes up to ½" B.S.P.

ITEM	O/D OF PIPE	Z B.S.P. Thread	X Bore	V	U	T	Hex. A/F S	
							Min.	Max.
A	IN. 3/16	IN. 1/8	IN. 3/32	IN. 0.22	IN. 1.55	IN. 0.43	IN. 0.595	IN. 0.600
B	1	1	5/32	0.28	1.73	0.46	0.705	0.710
BB	5/16	19 T.P.I. Whit. Form 0.60 O/D	3/16	0.32	1.85	0.48	0.815	0.820
C	3/8	3	1/4	0.32	1.97	0.53	0.915	0.920
CC	7/16	14 T.P.I. Whit. Form 0.75 O/D	5/16	0.32	2.06	0.57	1.002	1.010
D	1/2	1	3/8	0.32	2.12	0.60	1.002	1.010

Brown Brothers Engineering Ltd

AGS 1103

UNION BODY

Material : ALUM. ALLOY (ANODISED)

Working Pressures :

3000 lb./sq. in. for sizes up to $\frac{1}{2}$ " B.S.P.
 500 lb./sq. in. for sizes $\frac{5}{8}$ " to 1" B.S.P.
 200 lb./sq. in. for sizes $1\frac{1}{4}$ " to $2\frac{1}{2}$ " B.S.P.

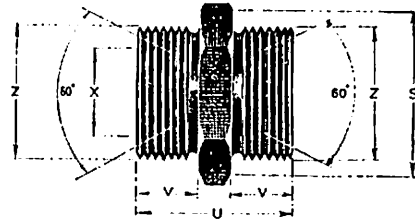

ITEM	NOMINAL DIA. OF PIPE	Z B.S.P. Thread	X Dia. Bore	V	U	HEX. A/F S	
						Min.	Max.
A	$\frac{1}{8}$ "	$\frac{1}{8}$ "	$\frac{3}{32}$ "	0.45	1.15	0.595	0.604
B	$\frac{1}{4}$ "	$\frac{1}{4}$ "	$\frac{5}{32}$ "	0.45	1.18	0.705	0.710
BB	$\frac{3}{8}$ "	19 T.P.I. 0.60 O/D	$\frac{1}{4}$ "	0.52	1.29	0.815	0.820
C	$\frac{1}{2}$ "	$\frac{1}{2}$ "	$\frac{1}{2}$ "	0.52	1.31	0.915	0.920
CC	$\frac{3}{4}$ "	14 T.P.I. 0.75 O/D	$\frac{3}{8}$ "	0.55	1.38	1.002	1.010
D	$\frac{1}{2}$ "	$\frac{1}{2}$ "	$\frac{3}{8}$ "	0.65	1.58	1.002	1.010
E	$\frac{3}{4}$ "	$\frac{3}{4}$ "	$\frac{1}{2}$ "	0.70	1.70	1.092	1.100
F	$\frac{7}{8}$ "	$\frac{7}{8}$ "	$\frac{1}{2}$ "	0.75	1.80	1.292	1.300
G	1"	1"	$\frac{7}{8}$ "	0.80	1.95	1.382	1.390
H	1"	1"	$\frac{1}{2}$ "	0.80	1.95	1.658	1.670
J	$1\frac{1}{4}$ "	$1\frac{1}{4}$ "	$1\frac{1}{4}$ "	0.83	2.06	2.035	2.050
K	$1\frac{1}{2}$ "	$1\frac{1}{2}$ "	$1\frac{1}{4}$ "	0.85	2.10	2.204	2.220
L	$1\frac{3}{4}$ "	$1\frac{3}{4}$ "	$1\frac{1}{4}$ "	0.95	2.35	2.390	2.410
M	2"	2"	$1\frac{3}{4}$ "	1.00	2.50	2.735	2.760
P	$2\frac{1}{2}$ "	$2\frac{1}{2}$ "	$2\frac{1}{4}$ "	1.10	2.70	3.320	3.340

AGS 1104

CONE ADAPTOR

Material : ALUM. ALLOY (ANODISED)

Working Pressure :

3000 lb./sq. in. for sizes up to $\frac{1}{2}$ " B.S.P.

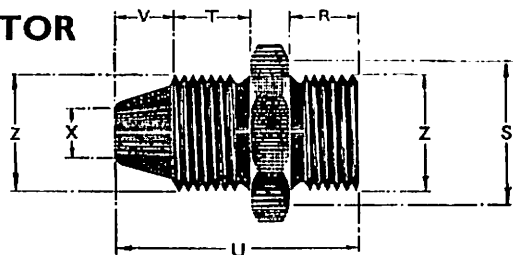

ITEM	O/D OF PIPE	Z B.S.P. Thread	X Dia. Bore	V	U	T	HEX. A/F S		R
							Min.	Max.	
A	$\frac{1}{8}$ "	$\frac{1}{8}$ "	$\frac{1}{16}$ "	0.22	1.25	0.43	0.595	0.600	0.35
B	$\frac{1}{4}$ "	$\frac{1}{4}$ "	$\frac{1}{8}$ "	0.28	1.34	0.46	0.705	0.710	0.35
BB	$\frac{3}{8}$ "	19 T.P.I. Whit. Form. 0.60 O/D	$\frac{1}{4}$ "	0.32	1.45	0.48	0.815	0.820	0.40
C	$\frac{1}{2}$ "	$\frac{1}{2}$ "	$\frac{1}{2}$ "	0.32	1.52	0.53	0.915	0.920	0.40
CC	$\frac{3}{4}$ "	14 T.P.I. Whit. Form 0.75 O/D	$\frac{3}{8}$ "	0.32	1.62	0.57	1.002	1.010	0.45
D	$\frac{1}{2}$ "	$\frac{1}{2}$ "	$\frac{1}{2}$ "	0.32	1.70	0.60	1.002	1.010	0.50

Brown Brothers Engineering Ltd

AGS 1105

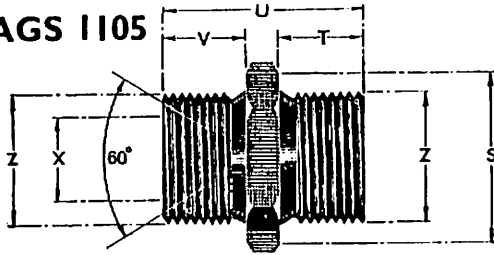

UNION ADAPTOR

Material : ALUM. ALLOY (ANODISED)

Working Pressures :

3000 lb./sq. in. for sizes up to $\frac{1}{2}$ " B.S.P.
 500 lb./sq. in. for sizes $\frac{5}{8}$ " to 1" B.S.P.
 200 lb./sq. in. for sizes $1\frac{1}{4}$ " to $2\frac{1}{2}$ " B.S.P.

ITEM	DIA. OF PIPE	Z	X	V	U	T	S HEX. A/F	
		B.S.P. Thread	Dia. Bore				Min.	Max.
A	$\frac{1}{2}$ "	$\frac{1}{2}$ "	$\frac{3}{8}$ "	0.45	1.05	0.35	0.595	0.600
B	$\frac{3}{4}$ "	$\frac{3}{4}$ "	$\frac{5}{8}$ "	0.45	1.05	0.35	0.705	0.710
BB	$\frac{1}{2}$ "	19 T.P.I. Whit. Form 0.60 O/D	$\frac{3}{8}$ "	0.52	1.17	0.40	0.815	0.820
C	$\frac{3}{4}$ "	$\frac{3}{4}$ "	$\frac{1}{2}$ "	0.52	1.19	0.40	0.915	0.920
CC	$\frac{1}{2}$ "	14 T.P.I. Whit. Form 0.75 O/D	$\frac{5}{16}$ "	0.55	1.28	0.45	1.002	1.010
D	$\frac{3}{4}$ "	$\frac{3}{4}$ "	$\frac{1}{2}$ "	0.55	1.43	0.50	1.002	1.010
E	$\frac{1}{2}$ "	$\frac{1}{2}$ "	$\frac{1}{2}$ "	0.70	1.50	0.50	1.092	1.100
F	$\frac{3}{4}$ "	$\frac{3}{4}$ "	$\frac{1}{2}$ "	0.75	1.60	0.55	1.292	1.300
G	$\frac{1}{2}$ "	$\frac{1}{2}$ "	$\frac{3}{8}$ "	0.80	1.75	0.60	1.382	1.390
H	1"	1"	$\frac{1}{2}$ "	0.80	1.80	0.65	1.658	1.670
J	$1\frac{1}{4}$ "	$1\frac{1}{4}$ "	$1\frac{1}{4}$ "	0.83	1.98	0.75	2.035	2.050
K	$1\frac{1}{2}$ "	$1\frac{1}{2}$ "	$1\frac{1}{4}$ "	0.85	2.05	0.80	2.200	2.220
L	$1\frac{3}{4}$ "	$1\frac{3}{4}$ "	$1\frac{3}{8}$ "	0.95	2.30	0.90	2.390	2.410
M	2"	2"	$1\frac{1}{2}$ "	1.00	2.45	0.95	2.735	2.760
P	$2\frac{1}{2}$ "	$2\frac{1}{2}$ "	$2\frac{1}{4}$ "	1.10	2.55	0.95	3.320	3.340

AGS 1106

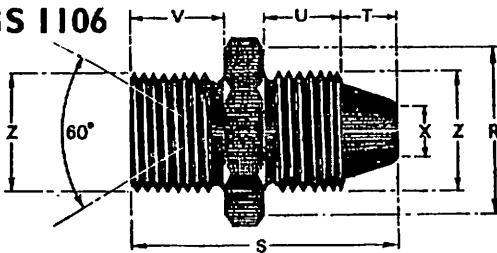

UNION BODY

Material : ALUM. ALLOY (ANODISED)

Working Pressure :

3000 lb./sq. in. for sizes up to $\frac{1}{2}$ " B.S.P.

ITEM	O/D OF PIPE	Z	X	V	U	T	S	R HEX. A/F	
		B.S.P. Thread	Bore					Min.	Max.
A	$\frac{1}{2}$ "	$\frac{1}{2}$ "	$\frac{3}{8}$ "	0.45	0.43	0.22	1.35	0.595	0.600
B	$\frac{3}{4}$ "	$\frac{3}{4}$ "	$\frac{5}{8}$ "	0.45	0.46	0.28	1.44	0.705	0.710
BB	$\frac{1}{2}$ "	19 T.P.I. Whit. Form 0.60 O/D	$\frac{3}{8}$ "	0.52	0.48	0.32	1.57	0.815	0.820
C	$\frac{3}{4}$ "	$\frac{3}{4}$ "	$\frac{1}{2}$ "	0.52	0.53	0.32	1.61	0.915	0.920
CC	$\frac{1}{2}$ "	14 T.P.I. Whit. Form 0.75 O/D	$\frac{5}{16}$ "	0.55	0.57	0.32	1.72	1.002	1.010
D	$\frac{3}{4}$ "	$\frac{3}{4}$ "	$\frac{1}{2}$ "	0.55	0.60	0.32	1.85	1.002	1.010

Brown Brothers Engineering Ltd

AGS 1107

REDUCING CONE UNION

Material :

ALUM. ALLOY (ANODISED)

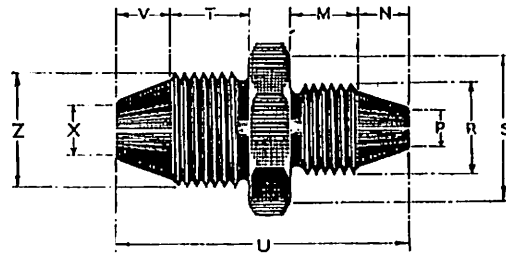

Working Pressure :

3000 lb./sq. in. for sizes up to 1/2" B.S.P.

ITEM	O/DIA. OF PIPE	Z	X	V	U	T	HEX. A/P S		R	P	N	M
							Max.	Min.				
A	1/4" x 1/8"	1/4"	1/8"	0.28	1.67	0.46	0.705	0.710	1/4"	1/8"	0.22	0.43
B	1/4" x 3/16"	19 T.P.I. Whit. Form 0.60 O/D	3/16"	0.32	1.73	0.48	0.815	0.820	1/4"	3/16"	0.22	0.43
C	1/4" x 1/4"	19 T.P.I. Whit. Form 0.60 O/D	1/4"	0.32	1.82	0.48	0.815	0.820	1/4"	1/4"	0.28	0.46
D	1/4" x 5/16"	1/4"	1/4"	0.32	1.78	0.53	0.915	0.920	1/4"	5/16"	0.22	0.43
E	1/4" x 3/8"	1/4"	1/4"	0.32	1.87	0.53	0.915	0.920	1/4"	3/8"	0.28	0.46
F	1/4" x 1/2"	1/4"	1/4"	0.32	1.93	0.53	0.915	0.920	19 T.P.I. Whit. Form 0.60 O/D	1/2"	0.32	0.48
G	1/4" x 3/4"	14 T.P.I. Whit. Form 0.75 O/D	3/8"	0.32	1.91	0.57	1.002	1.010	1/4"	3/8"	0.28	0.46
H	1/4" x 1 1/8"	14 T.P.I. Whit. Form 0.75 O/D	1/2"	0.32	1.97	0.57	1.002	1.010	19 T.P.I. Whit. Form 0.60 O/D	1/2"	0.32	0.48
J	1/4" x 1 1/4"	14 T.P.I. Whit. Form 0.75 O/D	1/2"	0.32	2.02	0.57	1.002	1.010	1/4"	1/2"	0.32	0.53
K	1/4" x 1 1/2"	1/4"	1/4"	0.32	1.94	0.60	1.002	1.010	1/4"	3/4"	0.28	0.46
L	1/4" x 1 3/8"	1/4"	1/4"	0.32	2.00	0.60	1.002	1.010	19 T.P.I. Whit. Form 0.60 O/D	1/2"	0.32	0.48
M	1/4" x 1 1/2"	1/4"	1/4"	0.32	2.06	0.60	1.002	1.010	1/4"	1/2"	0.32	0.53
N	1/4" x 1 3/4"	1/4"	1/4"	0.32	2.09	0.60	1.002	1.010	14 T.P.I. Whit. Form 0.75 O/D	1/2"	0.32	0.57

Brown Brothers Engineering Ltd

AGS 1108

REDUCING UNION

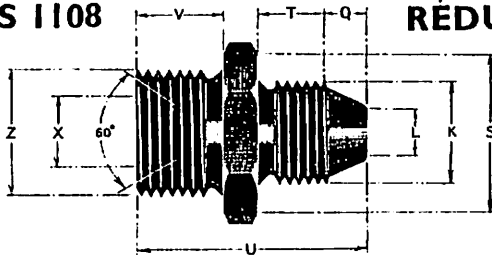

Material : ALUM. ALLOY (ANODISED)

Working Pressure :
500 lb./sq. in. for sizes $\frac{1}{8}$ " to 1" B.S.P.

ITEM	O/DIA. OF PIPE	Z	X	V	U	T	HEX. A/F S		Q	L	K
		B.S.P. Thread	Dia. Bore				Min.	Max.		Dia. Bore	B.S.P. Thread
A	IN. $\frac{1}{2} \times \frac{1}{2}$	IN. $\frac{1}{2}$	IN. $\frac{1}{4}$	IN. 0.70	IN. 1.85	IN. 0.53	IN. 1.092	IN. 1.100	IN. 0.32	IN. $\frac{1}{4}$	IN. $\frac{1}{2}$
B	IN. $\frac{3}{4} \times \frac{3}{4}$	IN. $\frac{3}{4}$	IN. $\frac{3}{8}$	0.70	1.92	0.60	1.092	1.100	0.32	$\frac{3}{8}$	$\frac{3}{4}$
C	IN. $1 \times \frac{1}{2}$	IN. $\frac{1}{2}$	IN. $\frac{1}{4}$	0.75	1.97	0.60	1.292	1.300	0.32	$\frac{1}{4}$	$\frac{1}{2}$

AGS 1109

REDUCING UNION

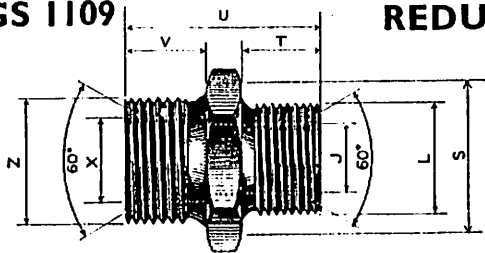

Material : ALUM. ALLOY (ANODISED)

Working Pressures :
3000 lb./sq. in. for sizes $\frac{3}{16}$ " to $\frac{1}{2}$ " B.S.P.
500 lb./sq. in. for sizes $\frac{5}{8}$ " to 1" B.S.P.
200 lb./sq. in. for sizes $1\frac{1}{4}$ " and $1\frac{1}{2}$ " B.S.P.

ITEM	NOMINAL DIA. OF PIPES	Z	X	V	U	T	HEX. A/F S		L	J
		B.S.P. Thread	Dia. Bore				Min.	Max.	B.S.P. Thread	Dia. Bore
A	IN. $\frac{1}{2} \times \frac{1}{2}$	IN. $\frac{1}{2}$	IN. $\frac{1}{4}$	IN. 0.75	IN. 1.75	IN. 0.70	IN. 1.292	IN. 1.30	IN. $\frac{1}{4}$	IN. $\frac{1}{2}$
B	IN. $\frac{3}{4} \times \frac{3}{4}$	IN. $\frac{3}{4}$	IN. $\frac{3}{8}$	0.80	1.85	0.70	1.382	1.39	$\frac{3}{8}$	$\frac{3}{4}$
C	IN. $1 \times \frac{1}{2}$	IN. $\frac{1}{2}$	IN. $\frac{1}{4}$	0.80	1.90	0.75	1.382	1.39	$\frac{1}{4}$	$\frac{1}{2}$
D	IN. $1 \times \frac{3}{4}$	IN. $\frac{3}{4}$	IN. $\frac{3}{8}$	0.80	1.90	0.75	1.658	1.67	$\frac{3}{8}$	$\frac{3}{4}$
E	IN. 1×1	IN. 1	IN. $\frac{3}{8}$	0.80	1.95	0.80	1.658	1.67	$\frac{3}{8}$	$\frac{3}{4}$
F	IN. $1\frac{1}{4} \times \frac{1}{2}$	IN. $\frac{1}{2}$	IN. $\frac{1}{4}$	0.83	2.03	0.80	2.035	2.05	$\frac{1}{4}$	$\frac{1}{2}$
G	IN. $1\frac{1}{4} \times 1$	IN. 1	IN. $\frac{1}{4}$	0.83	2.03	0.80	2.035	2.05	1	$\frac{1}{2}$
H	IN. $1\frac{1}{4} \times 1$	IN. 1	IN. $\frac{1}{4}$	0.85	2.05	0.80	2.20	2.22	1	$\frac{1}{2}$
J	IN. $1\frac{1}{4} \times 1\frac{1}{2}$	IN. 1	IN. $\frac{1}{4}$	0.85	2.08	0.83	2.20	2.22	$1\frac{1}{4}$	$1\frac{1}{2}$
K	IN. $\frac{1}{2} \times \frac{3}{4}$	IN. $\frac{3}{4}$	IN. $\frac{3}{8}$	0.45	1.15	0.45	0.705	0.710	$\frac{3}{8}$	$\frac{1}{2}$
L	IN. $\frac{1}{2} \times \frac{1}{2}$	IN. $\frac{1}{2}$	IN. $\frac{1}{4}$	0.52	1.25	0.45	0.915	0.920	$\frac{1}{4}$	$\frac{1}{2}$
M	IN. $\frac{3}{4} \times \frac{1}{2}$	IN. $\frac{1}{2}$	IN. $\frac{1}{4}$	0.65	1.38	0.45	1.002	1.010	$\frac{1}{4}$	$\frac{3}{8}$
N	IN. $\frac{3}{4} \times \frac{3}{4}$	IN. $\frac{3}{4}$	IN. $\frac{3}{8}$	0.70	1.65	0.65	1.092	1.100	$\frac{3}{8}$	$\frac{3}{4}$
P	IN. $1 \times \frac{1}{2}$	IN. 1	IN. $\frac{1}{4}$	0.80	1.85	0.70	1.658	1.670	$\frac{1}{4}$	$\frac{1}{2}$
Q	IN. $\frac{3}{8} \times \frac{1}{2}$	19 T.P.I. 0.60 O/D	IN. $\frac{3}{8}$	0.52	1.22	0.45	0.815	0.820	$\frac{3}{8}$	$\frac{1}{2}$
R	IN. $\frac{1}{2} \times \frac{1}{2}$	IN. $\frac{1}{2}$	IN. $\frac{1}{4}$	0.65	1.45	0.52	1.002	1.010	$\frac{1}{4}$	$\frac{1}{2}$
S	IN. $\frac{3}{4} \times \frac{1}{2}$	14 T.P.I. 0.75 O/D	IN. $\frac{3}{4}$	0.55	1.35	0.52	1.002	1.010	$\frac{1}{4}$	$\frac{1}{2}$

Brown Brothers Engineering Ltd

AGS 1110

BULKHEAD UNION BODIES

(General Arrangement)

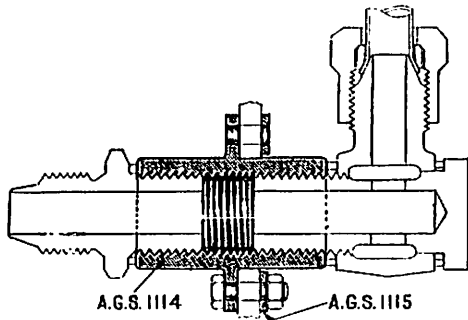

A.G.S. 1114 A.G.S. 1115

INTERNAL THREAD TYPE

Outside Dia. of Pipes	IN. 1/4	IN. 1/2	IN. 3/8	IN. 1/2	IN. 5/8	IN. 3/4	IN. 1	IN. 1 1/4	IN. 1 1/2	IN. 1 3/4	IN. 2	IN. 2 1/2
Size of Hole in Bulk-head	1 1/2	1 3/4	1 7/8	2	2 1/8	2 1/4	2 3/4	3 1/4	3 1/2	3 3/4	4 1/4	4 3/4

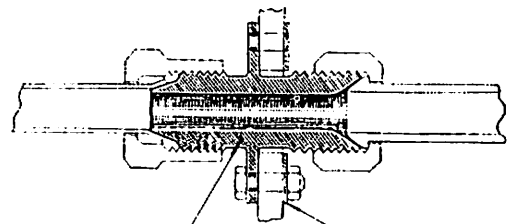

A.G.S. 1113 A.G.S. 1115

FOR USE WITH BULKHEADS NOT EXCEEDING .25"

Outside Dia. of Pipes	IN. 1/4	IN. 1/2	IN. 3/8	IN. 1/2	IN. 5/8	IN. 3/4	IN. 1	IN. 1 1/4	IN. 1 1/2	IN. 1 3/4	IN. 2	IN. 2 1/2
Dia. of Hole in Bulk-head	1 1/2	1 3/4	1 7/8	2	2 1/8	2 1/4	2 3/4	3 1/4	3 1/2	3 3/4	4 1/4	4 3/4

Double Female Ends : AGS 1112

Double Male Ends : AGS 1111

AGS 1111

CONE UNION BODY

Material :

ALUM. ALLOY (ANODISED)

Working Pressure :

3000 lb./sq. in. for sizes up to
1/2" B.S.P.

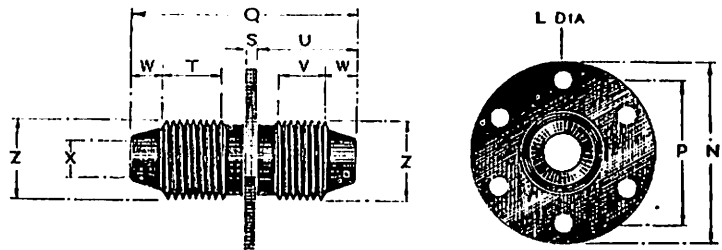

ITEM	O/D OF PIPE	Z	X	W	FULL V THREAD	U	FULL T THREAD	S	Q	P p.c.d.	N	L
		B.S.P. Thread	Dia. Bore									Dia. Drill
A	IN. 1/2	IN. 1/2	IN. 1/2	IN. 0.22	IN. 0.36	IN. 0.72	IN. 0.50	IN. 0.06	IN. 1.71	IN. 0.80	IN. 1.10	IN. 1 1/2
B	1/2	1/2	1/2	0.28	0.39	0.85	0.50	0.08	1.94	1.00	1.30	1 1/2
BB	1/2	14 T.P.I. Whit. Form 0.60 O/D	1/2	0.32	0.40	0.91	0.55	0.08	2.08	1.2	1.50	1 1/2
C	1/2	1/2	1/2	0.32	0.42	0.93	0.55	0.08	2.12	1.30	1.65	1 1/2
CC	1/2	14 T.P.I. Whit. Form 0.75 O/D	1/2	0.32	0.47	1.01	0.60	0.10	2.29	1.40	1.75	1 1/2
D	1/2	1/2	1/2	0.32	0.48	1.03	0.60	0.10	2.33	1.50	1.85	1 1/2

Brown Brothers Engineering Ltd

AGS 1112

UNION BODY

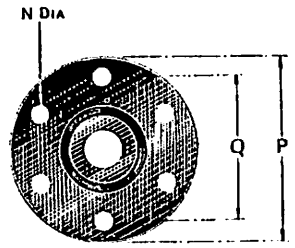
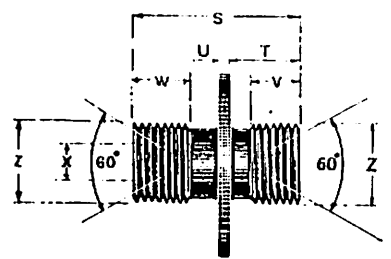

Material :
ALUM. ALLOY (ANODISED)

Working Pressures :
3000 lb./sq. in. for sizes up to 1/2" B.S.P.
500 lb./sq. in. for sizes 5/8" to 1" B.S.P.
200 lb./sq. in. for sizes 1 1/4" and 1 1/2" B.S.P.

ITEM	DIA. OF PIPE	Z	X	FULL W THREAD	FULL V THREAD	U	T	S	Q p.c.d	P	N
		B.S.P. Thread	Dia. Bore								Dia. Drill
	IN.	IN.	IN.	IN.	IN.	IN.	IN.	IN.	IN.	IN.	IN.
A	1/2	1/2	3/8	0.35	0.33	0.06	0.47	1.35	0.80	1.10	1/2
B	3/4	3/4	1/2	0.40	0.36	0.08	0.52	1.45	1.00	1.30	5/8
BB	1/2	19 T.P.I. Whit. Form 0.60 O/D	3/8	0.45	0.40	0.08	0.57	1.51	1.20	1.50	3/4
C	3/4	1/2	1/2	0.45	0.40	0.08	0.69	1.62	1.30	1.65	7/8
CC	1	14 T.P.I. Whit. Form 0.75 O/D	3/4	0.50	0.45	0.10	0.67	1.81	1.40	1.75	1 1/8
D	1 1/4	1 1/4	1 1/4	0.55	0.53	0.10	0.75	1.94	1.50	1.85	1 1/4
E	1 1/2	1 1/2	1 1/2	0.60	0.55	0.12	0.78	2.02	1.60	1.95	1 1/2
F	1 3/4	1 3/4	1 3/4	0.60	0.55	0.12	0.78	2.04	1.70	2.05	1 3/4
G	2	2	2	0.70	0.65	0.15	0.88	2.27	1.85	2.20	1 7/8
H	2 1/4	2 1/4	2 1/4	0.75	0.70	0.15	0.98	2.40	2.05	2.40	2
J	2 1/2	2 1/2	2 1/2	0.75	0.70	0.20	0.98	2.48	2.30	2.65	2 1/4
K	3	3	3	0.75	0.70	0.20	0.98	2.48	2.55	2.90	2 1/2

AGS 1113

UNION BODY

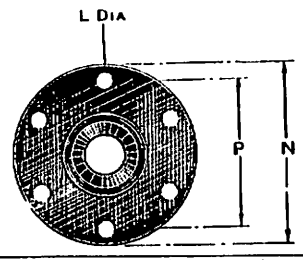
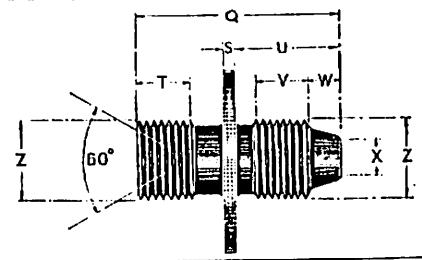

Material :
ALUM. ALLOY (ANODISED)

Working Pressure :
3000 lb./sq. in. for sizes up to 1/2" B.S.P.

ITEM	DIA. OF PIPE	Z	X	W	FULL V THREAD	U	FULL T THREAD	S	Q	P p.c.d.	N	L
		B.S.P. Thread	Dia. Bore									Dia. Drill
	IN.	IN.	IN.	IN.	IN.	IN.	IN.	IN.	IN.	IN.	IN.	IN.
A	1/2	1/2	3/8	0.22	0.36	0.72	0.35	0.06	1.60	0.80	1.10	1/2
B	3/4	3/4	1/2	0.23	0.39	0.85	0.40	0.08	1.78	1.00	1.30	5/8
BB	1/2	19 T.P.I. Whit. Form 0.60 O/D	3/8	0.32	0.40	0.91	0.45	0.08	1.85	1.20	1.50	3/4
C	3/4	1 1/2	1 1/2	0.32	0.42	0.93	0.45	0.08	1.96	1.30	1.65	7/8
CC	1	14 T.P.I. Whit. Form 0.75 O/D	3/4	0.32	0.47	1.01	0.50	0.10	2.18	1.40	1.75	1 1/8
D	1 1/4	1 1/4	1 1/4	0.32	0.48	1.03	0.55	0.10	2.22	1.50	1.85	1 1/4

Brown Brothers Engineering Ltd

AGS 1114

BULKHEAD SCREWED SLEEVE

Material :

ALUM. ALLOY
(ANODISED)

Working Pressures :

3000 lb./sq. in. for sizes up to $\frac{1}{2}$ " B.S.P.
500 lb./sq. in. for sizes $\frac{3}{8}$ " to 1" B.S.P.
200 lb./sq. in. for sizes $1\frac{1}{4}$ " and $1\frac{1}{2}$ " B.S.P.

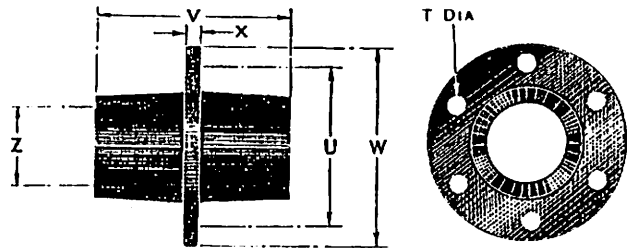

ITEM	O/D OF PIPE	Z	X	W	V	U p.c.d.	T
		B.S.P. Thread					Dia. of Drill
A	$\frac{1}{2}$ "	$\frac{1}{2}$ "	$0\cdot06$	$1\cdot3$	$1\cdot47$	$1\cdot00$	$\frac{1}{8}$ "
B	$\frac{3}{8}$ "	$\frac{3}{8}$ "	$0\cdot08$	$1\cdot5$	$1\cdot63$	$1\cdot20$	$\frac{3}{16}$ "
BB	$\frac{1}{2}$ "	19 T.P.I. Whit. Form $0\cdot60$ O/D	$0\cdot08$	$1\cdot65$	$1\cdot75$	$1\cdot30$	$\frac{1}{4}$ "
C	$\frac{3}{4}$ "	$\frac{3}{4}$ "	$0\cdot10$	$1\cdot75$	$1\cdot81$	$1\cdot40$	$\frac{1}{4}$ "
CC	$\frac{1}{2}$ "	14 T.P.I. Whit. Form $0\cdot75$ O/D	$0\cdot10$	$1\cdot85$	$1\cdot93$	$1\cdot50$	$\frac{1}{4}$ "
D	$\frac{3}{4}$ "	$\frac{3}{4}$ "	$0\cdot12$	$1\cdot95$	$1\cdot97$	$1\cdot60$	$\frac{1}{4}$ "
E	$\frac{1}{2}$ "	$\frac{1}{2}$ "	$0\cdot12$	$2\cdot05$	$1\cdot42$	$1\cdot70$	$\frac{1}{4}$ "
F	$\frac{3}{4}$ "	$\frac{3}{4}$ "	$0\cdot12$	$2\cdot20$	$1\cdot52$	$1\cdot85$	$\frac{3}{16}$ "
G	$\frac{1}{2}$ "	$\frac{1}{2}$ "	$0\cdot16$	$2\cdot40$	$1\cdot62$	$2\cdot05$	$\frac{1}{4}$ "
H	1	1	$0\cdot16$	$2\cdot50$	$1\cdot65$	$2\cdot15$	$\frac{1}{4}$ "
J	$1\frac{1}{4}$ "	$1\frac{1}{4}$ "	$0\cdot20$	$2\cdot90$	$1\cdot70$	$2\cdot55$	$\frac{1}{4}$ "
K	$1\frac{1}{2}$ "	$1\frac{1}{2}$ "	$0\cdot20$	$3\cdot15$	$1\cdot70$	$2\cdot78$	$\frac{1}{4}$ "

AGS 1115

WASHER PLATES

Material : MILD STEEL
(CADMIUM)

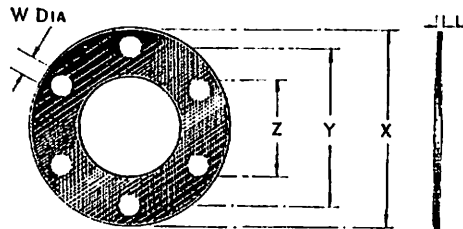

ITEM	Z	Y p.c.d.	X	W	U	ITEM	Z	Y p.c.d.	X	W	U
				Dia. of Drill	S.W.G.					Dia. of Drill	S.W.G.
1	$0\cdot500$	$0\cdot80$	$1\cdot10$	$\frac{1}{8}$ "	20	8	$1\cdot250$	$1\cdot70$	$2\cdot10$	$\frac{1}{4}$ "	18
2	$0\cdot687$	$1\cdot00$	$1\cdot30$	$\frac{3}{16}$ "	20	9	$1\cdot437$	$1\cdot85$	$2\cdot25$	$\frac{1}{4}$ "	18
3	$0\cdot844$	$1\cdot20$	$1\cdot50$	$\frac{1}{4}$ "	20	10	$1\cdot626$	$2\cdot05$	$2\cdot45$	$\frac{1}{4}$ "	18
4	$0\cdot906$	$1\cdot30$	$1\cdot70$	$\frac{1}{4}$ "	20	11	$1\cdot75$	$2\cdot15$	$2\cdot55$	$\frac{1}{4}$ "	18
5	$0\cdot968$	$1\cdot40$	$1\cdot80$	$\frac{1}{4}$ "	20	12	$1\cdot687$	$2\cdot30$	$2\cdot70$	$\frac{1}{4}$ "	18
6	$1\cdot062$	$1\cdot50$	$1\cdot90$	$\frac{1}{4}$ "	20	13	$2\cdot125$	$2\cdot55$	$2\cdot95$	$\frac{1}{4}$ "	18
7	$1\cdot156$	$1\cdot60$	$2\cdot00$	$\frac{1}{4}$ "	18	14	$2\cdot375$	$2\cdot78$	$3\cdot20$	$\frac{1}{4}$ "	18

Brown Brothers Engineering Ltd

AGS 1116

CONE ELBOW

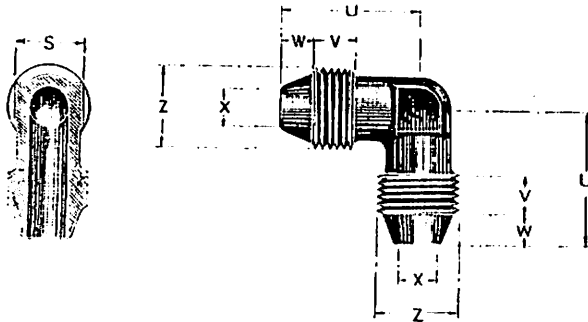

Material : ALUM. ALLOY
(ANODISED)

Working Pressure :
3000 lb./sq. in. for sizes up to $\frac{1}{2}$ " B.S.P.

ITEM	O/D OF PIPE	Z	X	W	V	U	S	
							Min.	Max.
A	$\frac{1}{8}$ "	$\frac{1}{8}$ " B.S.P. Thread	$\frac{1}{8}$ " Dia. Bore	0.22	0.30	0.90	0.321	0.324
B	$\frac{1}{4}$ "	$\frac{1}{4}$ "	$\frac{1}{4}$ "	0.28	0.30	1.05	0.410	0.413
BB	$\frac{1}{2}$ "	$\frac{1}{2}$ " 19 T.P.I. Whit. Form 0.60 O/D	$\frac{1}{2}$ "	0.32	0.31	1.15	0.410	0.445
C	$\frac{3}{4}$ "	$\frac{3}{4}$ "	$\frac{3}{4}$ "	0.32	0.37	1.25	0.520	0.525
CC	$\frac{7}{8}$ "	$\frac{7}{8}$ " 14 T.P.I. Whit. Form 0.75 O/D	$\frac{7}{8}$ "	0.32	0.39	1.32	0.595	0.600
D	1"	1"	1"	0.32	0.40	1.37	0.705	0.710

AGS 1117

ELBOW UNION

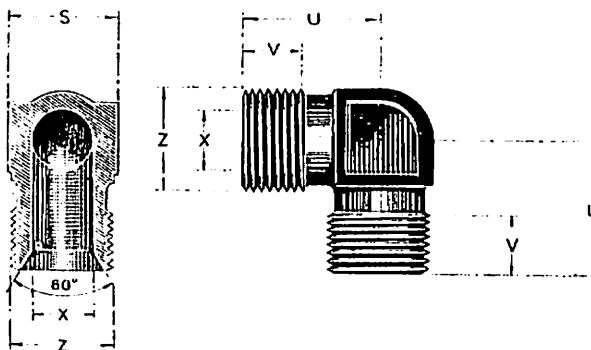

Material : ALUM. ALLOY
(ANODISED)

Working Pressures :
500 lb./sq. in. for sizes $\frac{1}{2}$ " to 1" B.S.P.
200 lb./sq. in. for sizes $1\frac{1}{4}$ " and $1\frac{1}{2}$ " B.S.P.

ITEM	O/D OF PIPE	Z	X	V	U	S	
						Min.	Max.
E	$\frac{1}{8}$ "	$\frac{1}{8}$ " B.S.P. Thread	$\frac{1}{8}$ " Dia. Bore	0.55	1.25	0.915	0.920
F	$\frac{1}{4}$ "	$\frac{1}{4}$ "	$\frac{1}{4}$ "	0.61	1.375	1.093	1.100
G	$\frac{3}{8}$ "	$\frac{3}{8}$ "	$\frac{3}{8}$ "	0.65	1.50	1.192	1.200
H	$\frac{1}{2}$ "	$\frac{1}{2}$ "	$\frac{1}{2}$ "	0.66	1.65	1.382	1.390
J	$\frac{3}{4}$ "	$\frac{3}{4}$ "	$\frac{3}{4}$ "	0.65	1.88	1.658	1.670
K	$\frac{1}{2}$ "	$\frac{1}{2}$ "	$\frac{1}{2}$ "	0.70	2.05	2.035	2.050

Brown Brothers Engineering Ltd

AGS 1118

CONE TEE

Material : ALUM. ALLOY
(ANODISED)

Working Pressure :
3000 lbs./sq. in. for sizes up to ½" B.S.P.

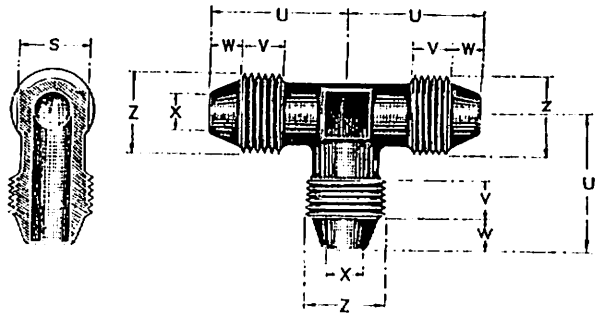

ITEM	O/D OF PIPE	Z	X	W	V	U	S	
							B.S.P. Thread	Dia. Bore
A	IN. 3/16	IN. 1/4	IN. 5/8	IN. 0.22	IN. 0.30	IN. 0.90	IN. 0.321	IN. 0.324
B	1/4	1/4	5/8	0.28	0.30	1.05	0.410	0.413
BB	5/16	19 T.P.I. Whit. Form 0.60 O/D	3/4	0.32	0.34	1.15	0.440	0.415
C	1/2	1/2	1/2	0.32	0.37	1.25	0.520	0.525
CC	3/8	14 T.P.I. Whit. Form 0.75 O/D	5/8	0.32	0.39	1.32	0.595	0.600
D	1/2	1/2	1/2	0.32	0.40	1.37	0.705	0.710

AGS 1119

TEE UNION

Material : ALUM. ALLOY
(ANODISED)

Working Pressures :
500 lb./sq. in. for sizes 5/8" to 1" B.S.P.
200 lb./sq. in. for sizes 1 1/4" and 1 1/2" B.S.P.

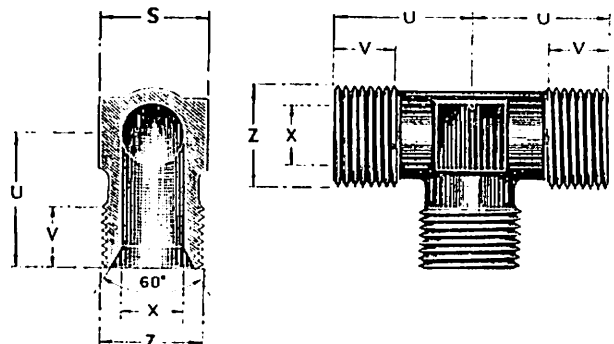

ITEM	O/D PIPE	Z	X	V	U	S	
						B.S.P. Thread	Dia. Bore
E	IN. 1/2	IN. 1/2	IN. 1/2	IN. 0.55	IN. 1.25	IN. 0.915	IN. 0.920
F	1/2	1/2	1/2	0.61	1.375	1.092	1.100
G	1/2	1/2	1/2	0.65	1.50	1.192	1.200
H	1	1	1/2	0.65	1.65	1.382	1.390
J	1 1/4	1 1/4	1 1/4	0.65	1.88	1.658	1.670
K	1 1/2	1 1/2	1 1/2	0.70	2.05	2.035	2.050

Brown Brothers Engineering Ltd.

AGS 1120

CONE TEES

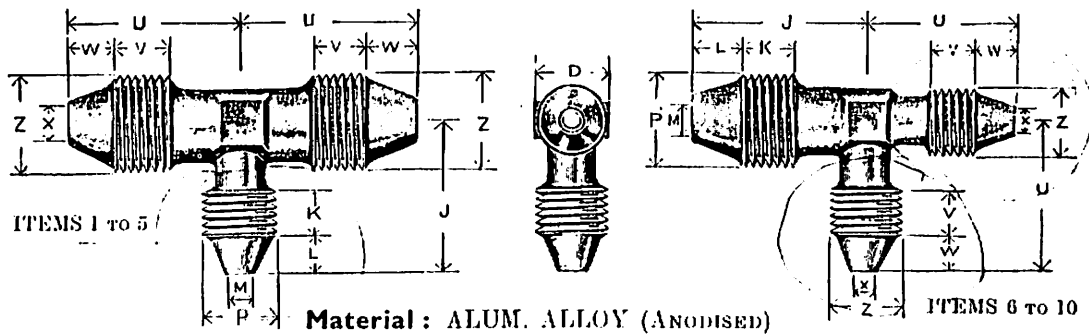

Material: ALUM. ALLOY (ANODISED)

Working Pressure: 3000 lb./sq. in. for sizes up to 1/2" B.S.P.

ITEM	SIZE OF TEE O/D OF PIPES	DIMENSIONS FOR EQUAL BRANCHES						
		Z	X	W	V	U	D ACROSS FLATS	
		B.S.P. THREAD	DIA. BORE	IN.	IN.	IN.	MIN.	MAX.
1	1" x 1" x 1/2"	1/4	3/8	0.28	0.30	1.05	0.410	0.413
2	1 1/8" x 1 1/8" x 1/2"	19 T.P.I. 0.60 O/D Whit. Form	3/8	0.32	0.31	1.15	0.410	0.445
3	1" x 1" x 1/4"	1/4	1/4	0.32	0.37	1.25	0.520	0.525
4	1 1/4" x 1 1/4" x 1/4"	14 T.P.I. 0.75 O/D Whit. Form	1/4	0.32	0.39	1.32	0.595	0.600
5	1" x 1" x 1"	1/4	1/4	0.32	0.40	1.37	0.705	0.710
6	1" x 1 1/8" x 1/2"	1/4	3/8	0.22	0.30	0.98	0.410	0.413
7	1 1/8" x 1 1/8" x 1/2"	1/4	3/8	0.22	0.30	1.02	0.440	0.445
8	1" x 1" x 1/4"	1/4	3/8	0.28	0.30	1.11	0.520	0.525
9	1 1/4" x 1 1/4" x 1/4"	19 T.P.I. 0.60 O/D Whit. Form	3/8	0.32	0.34	1.24	0.595	0.600
10	1" x 1" x 1"	1/4	1/4	0.32	0.37	1.35	0.705	0.710
11	1" x 1" x 3/8"	1/4	1/4	0.32	0.37	1.25	0.520	0.525
12	1 1/8" x 1 1/8" x 1/2"	14 T.P.I. 0.75 O/D Whit. Form	1/4	0.32	0.39	1.32	0.595	0.600
13	1" x 1" x 3/8"	1/4	1/4	0.32	0.40	1.37	0.705	0.710

ITEM	SIZE OF TEE O/D OF PIPES	DIMENSIONS FOR REMAINING BRANCH						
		P	M	L	K	J	D ACROSS FLATS	
		B.S.P. THREAD	DIA. BORE	IN.	IN.	IN.	MIN.	MAX.
1	1" x 1" x 1/2"	1/4	3/8	0.22	0.30	0.98	0.410	0.413
2	1 1/8" x 1 1/8" x 1/2"	1/4	3/8	0.22	0.30	1.02	0.440	0.445
3	1" x 1" x 1/4"	1/4	3/8	0.28	0.30	1.11	0.520	0.525
4	1 1/4" x 1 1/4" x 1/4"	19 T.P.I. 0.60 O/D Whit. Form	3/8	0.32	0.34	1.24	0.595	0.600
5	1" x 1" x 1"	1/4	1/4	0.32	0.37	1.35	0.705	0.710
6	1" x 1 1/8" x 1/2"	1/4	3/8	0.28	0.30	1.05	0.410	0.413
7	1 1/8" x 1 1/8" x 1/2"	19 T.P.I. 0.60 O/D Whit. Form	3/8	0.32	0.34	1.15	0.440	0.445
8	1" x 1" x 1/4"	1/4	1/4	0.32	0.37	1.25	0.520	0.525
9	1 1/4" x 1 1/4" x 1/4"	14 T.P.I. 0.75 O/D Whit. Form	1/4	0.32	0.39	1.32	0.595	0.600
10	1" x 1" x 1"	1/4	1/4	0.32	0.40	1.37	0.705	0.710
11	1" x 1" x 3/8"	1/4	3/8	0.22	0.30	1.05	0.520	0.525
12	1 1/8" x 1 1/8" x 1/2"	1/4	3/8	0.22	0.30	1.10	0.595	0.600
13	1" x 1" x 3/8"	1/4	3/8	0.22	0.30	1.13	0.705	0.710

Brown Brothers Engineering Ltd

AGS 1121

TEE UNIONS

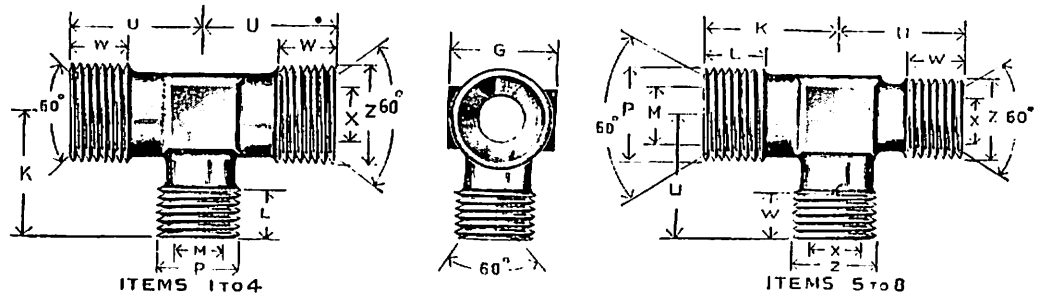

Material : ALUM. ALLOY (ANODISED)

Working Pressures : 500 lb./sq. in. for sizes $\frac{5}{8}$ " to 1" B.S.P. 200 lb./sq. in. for sizes $1\frac{1}{4}$ " & $1\frac{1}{2}$ " B.S.P.

ITEM	DIA. OF PIPES	DIMENSIONS FOR EQUAL BRANCHES				G ACROSS FLATS	
		Z	X	W	U	MIN.	MAX.
		B.S.P. THREAD	DIA. BORE				
1	$\frac{3}{4}$ " x $\frac{3}{4}$ " x $\frac{3}{4}$ "	$\frac{1}{2}$	$\frac{1}{8}$	0.61	1.37	1.092	1.100
2	1" x 1" x $\frac{3}{4}$ "	1	$\frac{3}{8}$	0.65	1.65	1.382	1.390
3	$1\frac{1}{4}$ " x $1\frac{1}{4}$ " x 1"	$1\frac{1}{2}$	$1\frac{1}{8}$	0.65	1.88	1.658	1.670
4	$1\frac{1}{2}$ " x $1\frac{1}{2}$ " x $1\frac{1}{2}$ "	$1\frac{1}{2}$	$1\frac{1}{8}$	0.70	2.05	2.035	2.050
5	$\frac{3}{4}$ " x $\frac{3}{4}$ " x $\frac{3}{4}$ "	$\frac{3}{8}$	$\frac{1}{2}$	0.55	1.30	1.092	1.100
6	1" x $\frac{3}{4}$ " x $\frac{3}{4}$ "	$\frac{3}{8}$	$\frac{3}{8}$	0.61	1.50	1.382	1.390
7	$1\frac{1}{4}$ " x 1" x 1"	1	$\frac{3}{8}$	0.65	1.78	1.658	1.670
8	$1\frac{1}{2}$ " x $1\frac{1}{4}$ " x $1\frac{1}{4}$ "	$1\frac{1}{2}$	$1\frac{1}{8}$	0.65	1.95	2.035	2.050

ITEM	DIA. OF PIPES	DIMENSIONS FOR REMAINING BRANCH				G ACROSS FLATS	
		P	M	L	K	MIN.	MAX.
		B.S.P. THREAD	DIA. BORE				
1	$\frac{3}{4}$ " x $\frac{3}{4}$ " x $\frac{3}{4}$ "	$\frac{1}{8}$	$\frac{1}{2}$	0.55	1.30	1.092	1.100
2	1" x 1" x $\frac{3}{4}$ "	$\frac{3}{8}$	$\frac{3}{8}$	0.61	1.50	1.382	1.390
3	$1\frac{1}{4}$ " x $1\frac{1}{4}$ " x 1"	1	$\frac{3}{8}$	0.65	1.78	1.658	1.670
4	$1\frac{1}{2}$ " x $1\frac{1}{2}$ " x $1\frac{1}{4}$ "	$1\frac{1}{2}$	$1\frac{1}{8}$	0.65	1.95	2.035	2.050
5	$\frac{3}{4}$ " x $\frac{3}{4}$ " x $\frac{3}{4}$ "	$\frac{3}{8}$	$\frac{3}{8}$	0.61	1.37	1.092	1.100
6	1" x $\frac{3}{4}$ " x $\frac{3}{4}$ "	1	$\frac{3}{8}$	0.65	1.65	1.382	1.390
7	$1\frac{1}{4}$ " x 1" x 1"	$1\frac{1}{2}$	$1\frac{1}{8}$	0.65	1.88	1.658	1.670
8	$1\frac{1}{2}$ " x $1\frac{1}{4}$ " x $1\frac{1}{4}$ "	$1\frac{1}{2}$	$1\frac{1}{8}$	0.70	2.05	2.035	2.050

Brown Brothers Engineering Ltd

AGS 1122

CONE & NIPPLE TEES

**Material : ALUM. ALLOY
(ANODISED)**

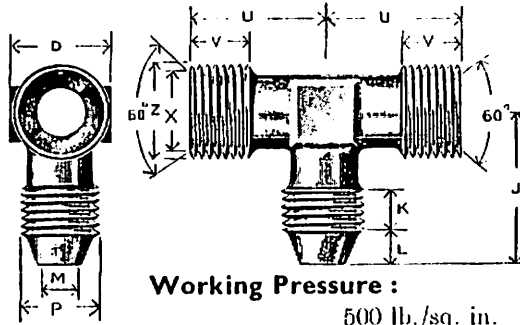

Working Pressure :
500 lb./sq. in.

ITEM	SIZE OF TEE O/D OF PIPE	Z	X	V	U	P	M	L	K	J	D ACROSS FLATS
		B.S.P. THREAD	DIA. BORE			B.S.P. THREAD	DIA. BORE				
1	1/2" x 1/2" x 1/2"	IN. 1/2	IN. 1/2	IN. 0.55	IN. 1.25	IN. 1/2	IN. 3/8	IN. 0.32	IN. 0.40	IN. 1.41	IN. 0.920

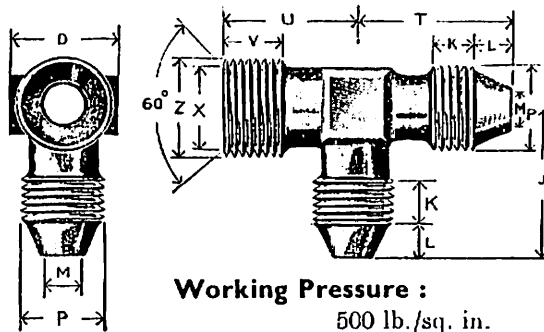

Working Pressure :
500 lb./sq. in.

ITEM	SIZE OF TEE O/D OF PIPE	Z	X	V	T	U	P	M	L	K	J	D ACROSS FLATS
		B.S.P. THREAD	DIA. BORE				B.S.P. THREAD	DIA. BORE				
2	1/2" x 1/2" x 1/2"	IN. 1/2	IN. 1/2	IN. 0.55	IN. 1.41	IN. 1.25	IN. 1/2	IN. 3/8	IN. 0.32	IN. 0.40	IN. 1.41	IN. 0.920

Brown Brothers Engineering Ltd

AGS 1123

CONE PIECE (4-WAY)

Material :
ALUM. ALLOY
(ANODISED)

Working Pressure :
3000 lb./sq. in. for sizes up to $\frac{1}{2}$ " B.S.P.

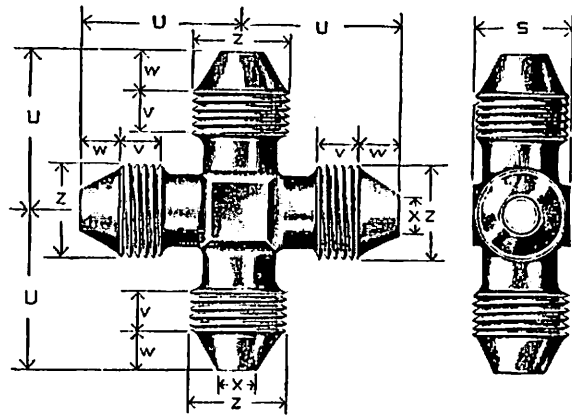

ITEM	DIA. OF PIPE	Z	X	W	V	U	S ACROSS FLATS	
		B.S.P. THREAD	DIA. BORE				MIN.	MAX.
A	$\frac{1}{4}$	$\frac{1}{2}$	$\frac{1}{8}$	0.22	0.30	0.90	0.410	0.413
B	$\frac{1}{2}$	$\frac{1}{2}$	$\frac{1}{8}$	0.28	0.30	1.05	0.520	0.525
BB	$\frac{1}{2}$	19 T.P.I. Whit. Form 0.80 O/D	$\frac{1}{8}$	0.32	0.34	1.15	0.595	0.600
C	$\frac{3}{4}$	$\frac{1}{2}$	$\frac{1}{8}$	0.32	0.37	1.25	0.705	0.710
CC	$\frac{3}{4}$	14 T.P.I. Whit. Form 0.75 O/D	$\frac{1}{8}$	0.32	0.39	1.32	0.815	0.820
D	$\frac{1}{2}$	$\frac{1}{2}$	$\frac{1}{8}$	0.32	0.40	1.37	0.815	0.820

AGS 1124

UNION PIECE (4-WAY)

Material :
ALUM. ALLOY
(ANODISED)

Working Pressures :
500 lb./sq. in. for sizes $\frac{3}{8}$ " to 1" B.S.P.
200 lb./sq. in. for sizes $1\frac{1}{4}$ " & $1\frac{1}{2}$ " B.S.P.

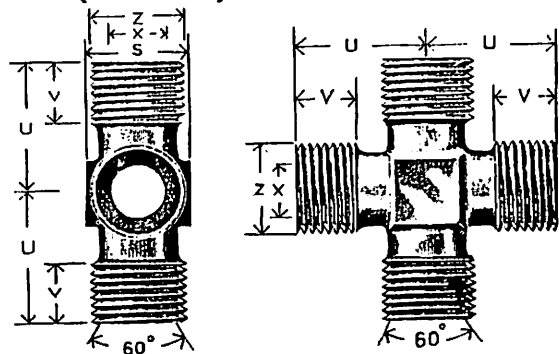

ITEM	DIA. OF PIPE	Z	X	V	U	S ACROSS FLATS	
		B.S.P. THREAD	DIA. BORE			MIN.	MAX.
E	$\frac{1}{2}$	$\frac{1}{2}$	$\frac{1}{8}$	0.55	1.25	0.915	0.920
F	$\frac{3}{4}$	$\frac{1}{2}$	$\frac{1}{8}$	0.61	1.375	1.092	1.100
G	$\frac{1}{2}$	$\frac{1}{2}$	$\frac{1}{8}$	0.65	1.50	1.192	1.20
H	1	1	$\frac{1}{8}$	0.65	1.65	1.382	1.390
J	$1\frac{1}{4}$	$1\frac{1}{2}$	$1\frac{1}{8}$	0.65	1.88	1.658	1.670
K	$1\frac{1}{2}$	$1\frac{1}{2}$	$1\frac{1}{8}$	0.70	2.05	2.035	2.050

AGS 1125

Brown Brothers Engineering Ltd
CONE PIECE (4-WAY)

Material : ALUM. ALLOY
 (ANODISED)

Working Pressure :
 3000 lb./sq. in. for sizes up to 1" B.S.P.

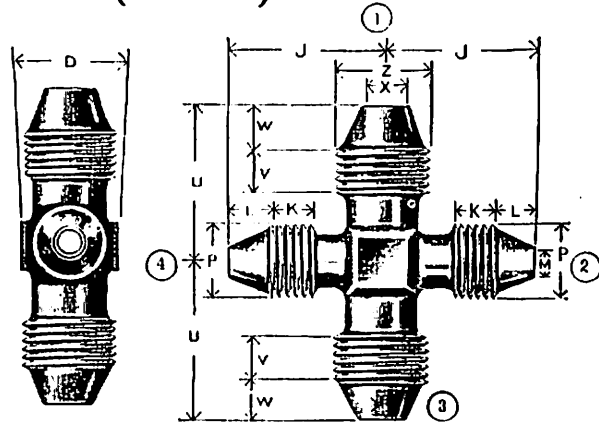

DIMENSIONS FOR BRANCHES 1 AND 3

ITEM	O/DIA. OF PIPES	Z B.S.P. THREAD IN.	X DIA. BORE IN.	W IN.	V IN.	U IN.	D ACROSS FLATS	
							MIN. IN.	MAX. IN.
1	1" x 1.5"	1/2	3/8	0.28	0.30	1.05	0.520	0.525
2	1.5" x 1.5"	19 T.P.I. Whit. Form 0.60 O/D	3/8	0.32	0.34	1.15	0.595	0.600
3	1.5" x 1"	19 T.P.I. Whit. Form 0.60 O/D	3/8	0.32	0.34	1.15	0.595	0.600
4	1" x 1"	1/2	1/2	0.32	0.37	1.25	0.705	0.710
5	1" x 1.5"	1/2	1/2	0.32	0.37	1.25	0.705	0.710
6	1.5" x 1"	14 T.P.I. Whit. Form 0.75 O/D	1/2	0.32	0.39	1.32	0.815	0.820
7	1.5" x 1.5"	14 T.P.I. Whit. Form 0.75 O/D	1/2	0.32	0.39	1.32	0.815	0.820
8	1" x 1"	1/2	1/2	0.32	0.40	1.37	0.815	0.820
9	1" x 1.5"	1/2	1/2	0.32	0.40	1.37	0.815	0.820
10	1" x 1"	1/2	1/2	0.32	0.40	1.37	0.815	0.820

DIMENSIONS FOR BRANCHES 2 AND 4

ITEM	O/DIA. OF PIPES	P B.S.P. THREAD IN.	M DIA. BORE IN.	L IN.	K IN.	J IN.	D ACROSS FLATS	
							MIN. IN.	MAX. IN.
1	1" x 1.5"	1/2	3/8	0.22	0.30	0.98	0.520	0.525
2	1.5" x 1.5"	1/2	3/8	0.22	0.30	1.02	0.595	0.600
3	1.5" x 1"	1/2	3/8	0.28	0.30	1.08	0.595	0.600
4	1" x 1"	1/2	1/2	0.28	0.30	1.11	0.705	0.710
5	1" x 1.5"	19 T.P.I. Whit. Form 0.60 O/D	3/8	0.32	0.34	1.19	0.705	0.710
6	1.5" x 1"	1/2	3/8	0.28	0.30	1.16	0.815	0.820
7	1.5" x 1.5"	19 T.P.I. Whit. Form 0.60 O/D	3/8	0.32	0.34	1.24	0.815	0.820
8	1" x 1"	1/2	1/2	0.28	0.30	1.19	0.815	0.820
9	1" x 1.5"	19 T.P.I. Whit. Form 0.60 O/D	3/8	0.32	0.34	1.27	0.815	0.820
10	1" x 1"	1/2	1/2	0.32	0.37	1.35	0.815	0.820

Brown Brothers Engineering Ltd

UNION PIECES (4-WAY)

AGS 1126

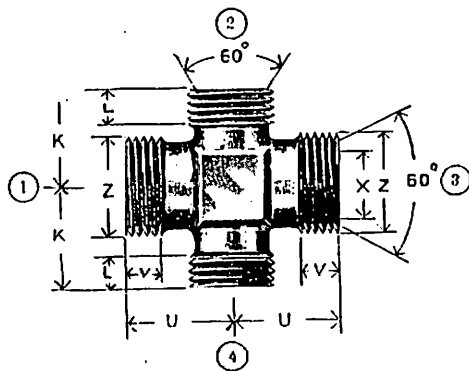

Material : ALUM. ALLOY
(ANODISED)

Working Pressures :
500 lb./sq. in. for sizes
5/8" to 1" B.S.P.
200 lb./sq. in. for sizes
1 1/4" and 1 1/2" B.S.P.

ITEM	DIA. OF PIPES	DIMENSIONS FOR BRANCHES 1 AND 3					
		Z	X	V	U	F ACROSS FLATS	
		B.S.P. THREAD	DIA. BORE			MIN.	MAX.
1	3/4" x 3/4"	IN. 3/8	IN. 3/8	IN. 0.61	IN. 1.375	IN. 1.092	IN. 1.10
2	7/8" x 3/4"	3/8	3/8	0.65	1.50	1.192	1.20
3	1" x 3/4"	1	7/8	0.65	1.65	1.382	1.39
4	1" x 1/2"	1	7/8	0.65	1.65	1.382	1.39
5	1 1/4" x 3/4"	1 1/4	1 1/8	0.65	1.88	1.658	1.67
6	1 1/4" x 1"	1 1/4	1 1/8	0.65	1.88	1.658	1.67
7	1 1/2" x 1"	1 1/2	1 1/8	0.70	2.05	2.035	2.05
8	1 1/2" x 1 1/4"	1 1/2	1 1/8	0.70	2.05	2.035	2.05

ITEM	DIA. OF PIPES	DIMENSIONS FOR BRANCHES 2 AND 4					
		P	M	L	K	F ACROSS FLATS	
		B.S.P. THREAD	DIA. BORE			MIN.	MAX.
1	3/4" x 3/4"	IN. 3/8	IN. 1/2	IN. 0.55	IN. 1.30	IN. 1.092	IN. 1.10
2	3/4" x 3/4"	3/8	1/2	0.55	1.30	1.192	1.20
3	1" x 3/4"	3/8	1/2	0.55	1.45	1.382	1.39
4	1" x 1/2"	3/8	3/8	0.61	1.50	1.382	1.39
5	1 1/4" x 3/4"	7/8	3/4	0.65	1.72	1.658	1.67
6	1 1/4" x 1"	1	7/8	0.65	1.78	1.658	1.67
7	1 1/2" x 1"	1	7/8	0.65	1.90	2.035	2.05
8	1 1/2" x 1 1/4"	1 1/4	1 1/8	0.65	1.95	2.035	2.05

Brown Brothers Engineering Ltd

AGS 1127 CONE & NIPPLE PIECES (4-WAY)

Material : ALUM. ALLOY (ANODISED)

Working Pressure : 500 lb./sq. in. for sizes $\frac{5}{8}$ " to 1" B.S.P.

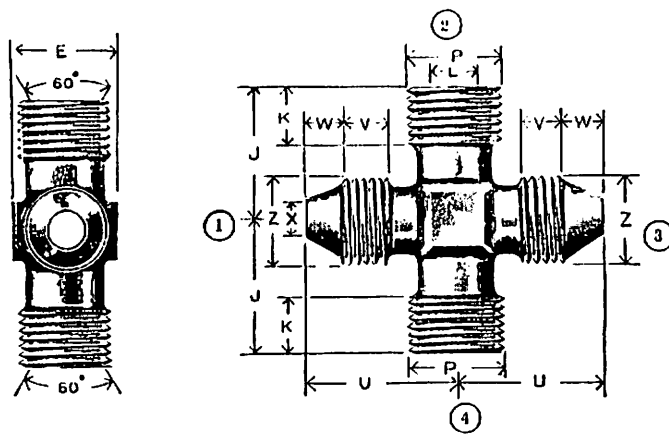

		DIMENSIONS FOR BRANCHES 1 AND 3					E ACROSS FLATS	
ITEM	DIA. OF PIPES	Z	X	W	V	U	MIN.	MAX.
		B.S.P. THREAD	DIA. BORE				IN.	IN.
1	$\frac{5}{8}$ " \times $\frac{3}{8}$ "	$\frac{1}{2}$	$\frac{1}{4}$	0.32	0.37	1.33	0.915	0.920
2	$\frac{5}{8}$ " \times $\frac{1}{2}$ "	$\frac{1}{2}$	$\frac{3}{8}$	0.32	0.40	1.42	0.915	0.920
3	$\frac{3}{4}$ " \times $\frac{1}{2}$ "	$\frac{1}{2}$	$\frac{3}{8}$	0.32	0.40	1.50	1.092	1.10

		DIMENSIONS FOR BRANCHES 2 AND 4				E ACROSS FLATS	
ITEM	DIA. OF PIPES	P	L	K	J	MIN.	MAX.
		B.S.P. THREAD	DIA. BORE			IN.	IN.
1	$\frac{5}{8}$ " \times $\frac{3}{8}$ "	$\frac{1}{2}$	$\frac{1}{2}$	0.55	1.25	0.915	0.920
2	$\frac{5}{8}$ " \times $\frac{1}{2}$ "	$\frac{1}{2}$	$\frac{1}{2}$	0.55	1.25	0.915	0.920
3	$\frac{3}{4}$ " \times $\frac{1}{2}$ "	$\frac{3}{4}$	$\frac{3}{8}$	0.61	1.375	1.092	1.10

Brown Brothers Engineering Ltd

AGS 1128

**CONE AND UNION BANJOS
(USING ALUMINIUM OR COPPER WASHERS)**

(General Arrangement)

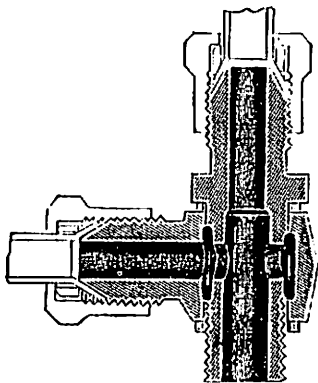

**SINGLE ENDED TYPE WITH
END CONNECTION ON BOLT**
Parts required :--
Body-AGS 1129
Banjo Bolt-AGS 1136 or 1214
Jointing Washer AGS 1138 or 1139

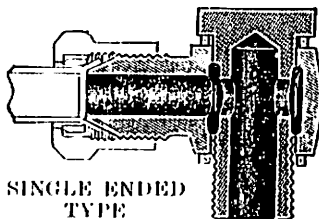

**SINGLE ENDED
TYPE**
Parts required :
Body-AGS 1129
Banjo Bolt-AGS 1135 or 1213
Jointing Washer-AGS 1138 or 1139

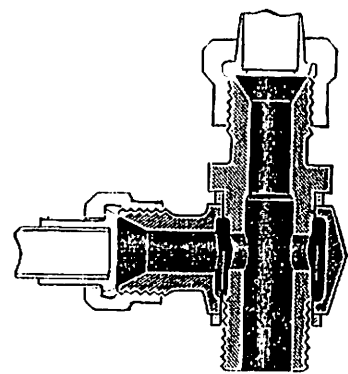

**SINGLE ENDED TYPE WITH
END CONNECTION ON BOLT**
Parts required :--
Body-AGS 1132
Banjo Bolt-AGS 1137 or 1215
Jointing Washer AGS 1138 or 1139

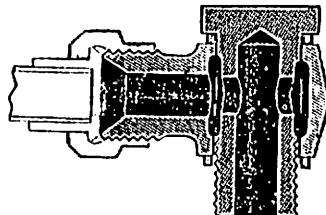

SINGLE ENDED TYPE
Parts required :
Body-AGS 1132
Banjo Bolt-
AGS 1135 or 1213
Jointing Washer-
AGS 1138 or 1139

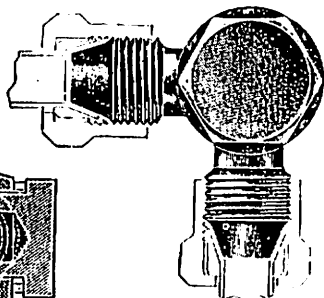

**RIGHT ANGLE
TYPE**
Parts required :
Body-AGS 1131
Banjo Bolt-AGS 1135 or 1213
Jointing Washer-
AGS 1138 or 1139

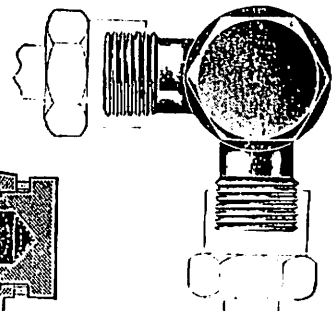

**RIGHT ANGLE
TYPE**
Parts required :
Body-AGS 1134
Banjo Bolt-
AGS 1135 or 1213
Jointing Washer-
AGS 1138 or 1139

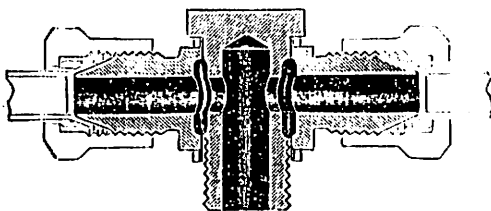
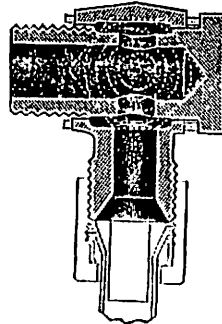
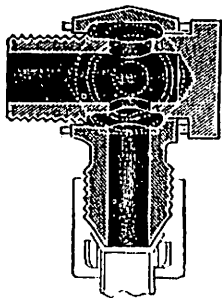

DOUBLE ENDED TYPE
Parts required : Body-AGS 1130, Banjo Bolt-1135 or 1213, and Jointing Washer-1138 or 1139

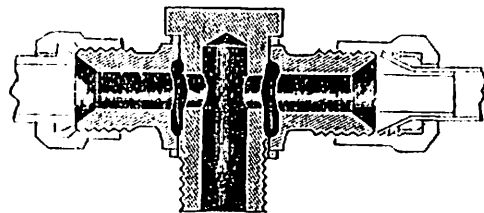

DOUBLE ENDED TYPE
Parts required : Body-AGS-1133, Banjo Bolt-1135 or 1213, and Jointing Washer-1138 or 1139

BONDED SEALS AGS 1186 MAY BE USED IN LIEU OF AGS 1138 AND 1139.

Brown Brothers Engineering Ltd

AGS 1129 SINGLE END CONE BANJO BODY

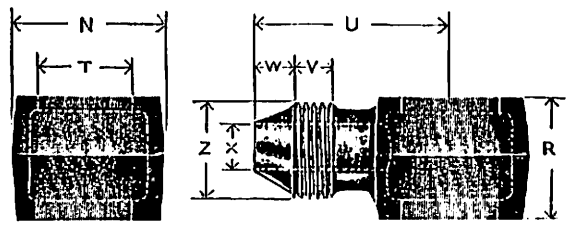

Material : ALUM. ALLOY
(ANODISED)

Working Pressure :
3000 lb/sq in. for sizes
up to 1/2" B.S.P.

ITEM	O/D OF PIPE	Z	X	W	V	U	T	R	N
		B.S.P. THREAD	BORE						
A	1/2"	IN. 1/2	IN. 3/8	IN. 0.22	IN. 0.30	IN. 1.05	IN. 0.383	IN. 0.60	IN. 0.75
B	1/2"	1/2	3/8	0.28	0.30	1.22	0.518	0.60	0.90
BB	1/2"	19 T.P.I. Whit. Form 0.60 O/D	3/8	0.32	0.34	1.35	0.60	0.70	1.00
C	1/2"	1/2	1/2	0.32	0.37	1.43	0.656	0.80	1.10
CC	1/2"	14 T.P.I. Whit. Form 0.75 O/D	3/8	0.32	0.39	1.56	0.75	0.90	1.20
D	1/2"	1/2	1/2	0.32	0.40	1.62	0.825	1.00	1.30

AGS 1130 DOUBLE END CONE BANJO BODY

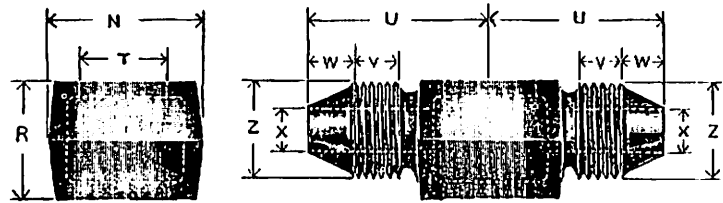

Material : ALUM. ALLOY
(ANODISED)

Working Pressure :
3000 lb./sq. in. for sizes
up to 1/2" B.S.P.

ITEM	O/D OR PIPE	Z	X	W	V	U	T	R	N
		B.S.P. THREAD	BORE						
A	IN. 1/2	IN. 1/2	IN. 3/8	IN. 0.22	IN. 0.30	IN. 1.05	IN. 0.383	IN. 0.60	IN. 0.75
B	1/2"	1/2	3/8	0.28	0.30	1.22	0.518	0.60	0.90
BB	1/2"	19 T.P.I. Whit. Form 0.60 O/D	3/8	0.32	0.34	1.35	0.60	0.70	1.00
C	1/2"	1/2	1/2	0.32	0.37	1.43	0.656	0.80	1.10
CC	1/2"	14 T.P.I. Whit. Form 0.75 O/D	3/8	0.32	0.39	1.56	0.750	0.90	1.20
D	1/2"	1/2	1/2	0.32	0.40	1.62	0.825	1.00	1.30

Brown Brothers Engineering Ltd

AGS 1131 DOUBLE R/A CONE BANJO BODY

Material : ALUM. ALLOY

(ANODISED)

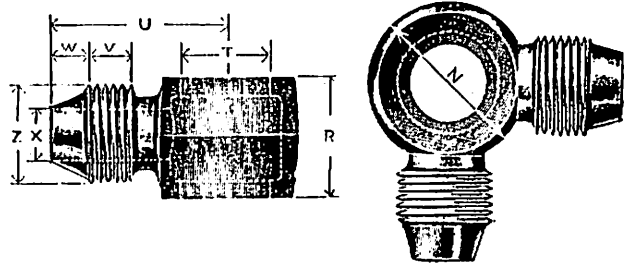

Working Pressure :

3000 lb./sq. in. for sizes up to $\frac{1}{2}$ " B.S.P.

ITEM	O/D OF PIPE	Z	X	W	V	U	T	R	N
		B.S.P. THREAD	BORE						
A	$\frac{1}{2}$ "	$\frac{1}{2}$ "	$\frac{3}{16}$ "	IN. 0.22	IN. 0.30	IN. 1.05	IN. 0.383	IN. 0.50	IN. 0.75
B	$\frac{3}{4}$ "	$\frac{3}{4}$ "	$\frac{1}{4}$ "	0.28	0.30	1.22	0.518	0.60	0.90
BB	$\frac{1}{2}$ "	19 T.P.I. Whit. Form 0.60 O/D	$\frac{3}{16}$ "	0.32	0.34	1.35	0.60	0.70	1.00
C	$\frac{1}{2}$ "	$\frac{3}{4}$ "	$\frac{1}{4}$ "	0.32	0.37	1.43	0.656	0.80	1.10
CC	$\frac{3}{4}$ "	11 T.P.I. Whit. Form 0.75 O/D	$\frac{1}{4}$ "	0.32	0.39	1.56	0.75	0.90	1.20
D	$\frac{1}{2}$ "	$\frac{3}{4}$ "	$\frac{3}{8}$ "	0.32	0.40	1.62	0.825	1.00	1.30

AGS 1132 SINGLE END UNION BANJO BODY

Material : ALUM. ALLOY

(ANODISED)

Working Pressures :

3000 lb./sq. in. for sizes up to $\frac{1}{2}$ " B.S.P.
500 lb./sq. in. for sizes $\frac{5}{8}$ " to 1" B.S.P.

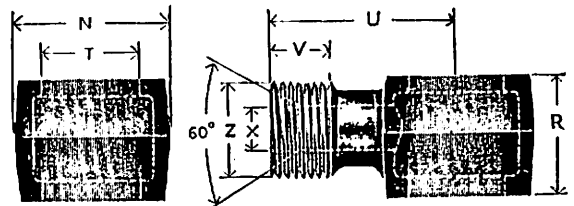

ITEM	DIA. OF PIPE	Z	X	V	U	T	R	N
		B.S.P. THREAD	DIA. BORE					
A	$\frac{1}{2}$ "	$\frac{1}{2}$ "	$\frac{3}{16}$ "	IN. 0.35	IN. 0.87	IN. 0.383	IN. 0.50	IN. 0.75
B	$\frac{3}{4}$ "	$\frac{3}{4}$ "	$\frac{1}{4}$ "	0.35	1.00	0.518	0.60	0.90
BB	$\frac{1}{2}$ "	19 T.P.I. Whit. Form 0.60 O/D	$\frac{3}{16}$ "	0.40	1.10	0.60	0.70	1.00
C	$\frac{1}{2}$ "	$\frac{3}{4}$ "	$\frac{1}{4}$ "	0.40	1.15	0.656	0.80	1.10
CC	$\frac{3}{4}$ "	14 T.P.I. Whit. Form 0.75 O/D	$\frac{1}{4}$ "	0.45	1.30	0.75	0.90	1.20
D	$\frac{1}{2}$ "	$\frac{3}{4}$ "	$\frac{1}{4}$ "	0.50	1.40	0.825	1.00	1.30
E	$\frac{3}{4}$ "	$\frac{3}{4}$ "	$\frac{1}{4}$ "	0.55	1.58	0.902	1.10	1.55
F	$\frac{1}{2}$ "	$\frac{3}{4}$ "	$\frac{1}{4}$ "	0.61	1.79	1.041	1.25	1.85
G	$\frac{3}{4}$ "	$\frac{3}{4}$ "	$\frac{1}{4}$ "	0.65	1.93	1.189	1.40	2.05
H	1"	1"	$\frac{1}{4}$ "	0.65	2.05	1.309	1.65	2.20

Brown Brothers Engineering Ltd

AGS 1133 DOUBLE END UNION BANJO BODY

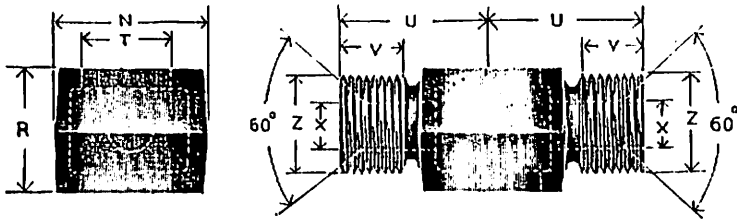

Material : ALUM. ALLOY
(ANODISED)

Working Pressures :
3000 lb./sq. in. for sizes up to $\frac{1}{2}$ " B.S.P.
500 lb./sq. in. for sizes $\frac{5}{8}$ " to 1" B.S.P.

ITEM	DIA. OF PIPE IN.	Z	X	V	U	T	R	N
		B.S.P. THREAD IN.	DIA. BORE IN.	IN.	IN.	IN.	IN.	IN.
A	$\frac{1}{2}$	$\frac{1}{2}$	$\frac{3}{32}$	0.35	0.87	0.383	0.50	0.75
B	$\frac{3}{4}$	$\frac{3}{4}$	$\frac{3}{32}$	0.35	1.00	0.518	0.60	0.90
BB	$\frac{1}{2}$	19 T.P.I. Whit. Form 0.60 O/D	$\frac{1}{8}$	0.40	1.10	0.60	0.70	1.00
C	$\frac{3}{4}$	$\frac{3}{4}$	$\frac{1}{8}$	0.40	1.15	0.656	0.80	1.10
CC	$\frac{1}{2}$	14 T.P.I. Whit. Form 0.75 O/D	$\frac{1}{8}$	0.45	1.30	0.75	0.90	1.20
D	$\frac{3}{4}$	$\frac{3}{4}$	$\frac{1}{8}$	0.50	1.40	0.825	1.00	1.30
E	$\frac{1}{2}$	$\frac{1}{2}$	$\frac{1}{8}$	0.55	1.58	0.902	1.10	1.55
F	$\frac{3}{4}$	$\frac{3}{4}$	$\frac{1}{8}$	0.61	1.79	1.041	1.25	1.85
G	$\frac{1}{2}$	$\frac{1}{2}$	$\frac{1}{8}$	0.65	1.93	1.189	1.40	2.05
H	1	1	$\frac{1}{8}$	0.65	2.05	1.309	1.65	2.20

AGS 1134 DOUBLE R.A. UNION BANJO BODY

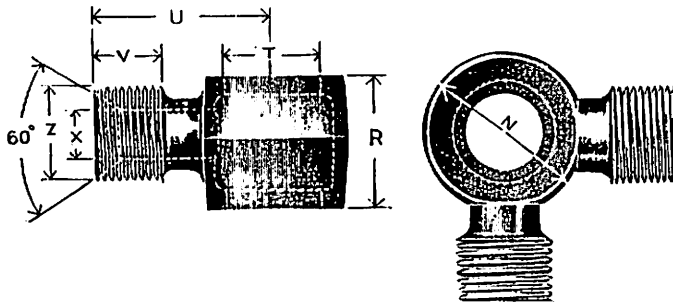

Material : ALUM. ALLOY
(ANODISED)

Working Pressures :
3000 lb./sq. in. for sizes up to $\frac{1}{2}$ " B.S.P.
500 lb./sq. in. for sizes $\frac{3}{8}$ " to 1" B.S.P.

ITEM	DIA. OF PIPE IN.	Z	X	V	U	T	R	N
		B.S.P. THREAD IN.	DIA. BORE IN.	IN.	IN.	IN.	IN.	IN.
A	$\frac{1}{2}$	$\frac{1}{2}$	$\frac{3}{32}$	0.35	0.87	0.383	0.50	0.75
B	$\frac{3}{4}$	$\frac{3}{4}$	$\frac{3}{32}$	0.35	1.00	0.518	0.60	0.90
BB	$\frac{1}{2}$	19 T.P.I. Whit. Form 0.60 O/D	$\frac{1}{8}$	0.40	1.10	0.60	0.70	1.00
C	$\frac{3}{4}$	$\frac{3}{4}$	$\frac{1}{8}$	0.40	1.15	0.656	0.80	1.10
CC	$\frac{1}{2}$	14 T.P.I. Whit. Form 0.75 O/D	$\frac{1}{8}$	0.45	1.30	0.75	0.90	1.20
D	$\frac{3}{4}$	$\frac{3}{4}$	$\frac{1}{8}$	0.50	1.40	0.825	1.00	1.30
E	$\frac{1}{2}$	$\frac{1}{2}$	$\frac{1}{8}$	0.55	1.58	0.902	1.10	1.55
F	$\frac{3}{4}$	$\frac{3}{4}$	$\frac{1}{8}$	0.61	1.79	1.041	1.25	1.85
G	$\frac{1}{2}$	$\frac{1}{2}$	$\frac{1}{8}$	0.65	1.93	1.189	1.40	2.05
H	1	1	$\frac{1}{8}$	0.65	2.05	1.309	1.65	2.20

Brown Brothers Engineering Ltd

AGS 1135

BANJO BOLT

Material : H.T. STEEL

(CADMIUM)

Working Pressures :

3000 lb./sq. in. for sizes up to $\frac{1}{2}$ " B.S.P.
 500 lb./sq. in. for sizes $\frac{5}{8}$ " to 1" B.S.P.

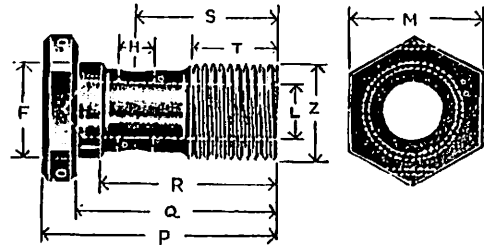

ITEM	O/D OF PIPE	Z	T	S	R	Q	P	M		L	H	F	
								MIN.	MAX.				
A	$\frac{1}{2}$ "	$\frac{1}{4}$ "	$\frac{1}{8}$ "	0.53	0.72	0.83	1.01	1.30	0.595	0.60	$\frac{1}{2}$ "	$\frac{1}{4}$ "	0.375
B	$\frac{3}{4}$ "	$\frac{1}{2}$ "	0.53	0.75	0.93	1.11	1.44	0.705	0.71	$\frac{3}{4}$ "	$\frac{3}{8}$ "	0.507	
BB	$\frac{1}{2}$ "	19 T.P.I. Whit. Form 0.60 O/D	0.60	0.88	1.06	1.26	1.60	0.815	0.82	$\frac{1}{2}$ "	$\frac{1}{4}$ "	0.589	
C	$\frac{3}{4}$ "	$\frac{1}{2}$ "	0.60	0.95	1.16	1.36	1.70	0.915	0.92	$\frac{3}{4}$ "	$\frac{1}{2}$ "	0.645	
CC	$\frac{1}{2}$ "	14 T.P.I. Whit. Form 0.75 O/D	0.68	1.05	1.28	1.51	1.85	1.002	1.01	$\frac{1}{2}$ "	$\frac{1}{4}$ "	0.736	
D	$\frac{3}{4}$ "	$\frac{1}{2}$ "	0.73	1.14	1.43	1.66	1.98	1.002	1.01	$\frac{3}{4}$ "	$\frac{1}{2}$ "	0.811	
E	$\frac{1}{2}$ "	$\frac{1}{2}$ "	0.73	1.20	1.53	1.76	2.10	1.092	1.10	$\frac{1}{2}$ "	$\frac{1}{4}$ "	0.886	
F	$\frac{3}{4}$ "	$\frac{1}{2}$ "	0.83	1.33	1.68	1.96	2.31	1.202	1.30	$\frac{3}{4}$ "	$\frac{1}{2}$ "	1.027	
G	$\frac{1}{2}$ "	$\frac{1}{2}$ "	0.88	1.48	1.88	2.16	2.55	1.382	1.39	$\frac{1}{2}$ "	$\frac{1}{4}$ "	1.175	
H	1	1	0.97	1.72	2.22	2.54	2.91	1.658	1.67	$\frac{1}{2}$ "	$\frac{1}{4}$ "	1.291	

AGS 1136 BANJO BOLT with Cone Head Connection

Material : H.T. STEEL

(CADMIUM)

Working Pressure :

3000 lb./sq. in. for sizes up to $\frac{1}{2}$ " B.S.P.

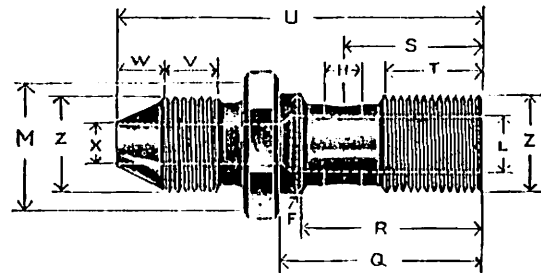

ITEM	O/D OF PIPE	Z	X	W	V	U	T	S	R	Q	M		L	H	F
											MIN.	MAX.			
A	$\frac{1}{2}$ "	$\frac{1}{4}$ "	$\frac{1}{2}$ "	0.22	0.36	1.98	0.53	0.72	0.83	1.01	0.595	0.600	$\frac{1}{2}$ "	$\frac{1}{4}$ "	0.375
B	$\frac{3}{4}$ "	$\frac{1}{2}$ "	$\frac{1}{2}$ "	0.28	0.39	2.22	0.53	0.75	0.93	1.11	0.705	0.710	$\frac{3}{4}$ "	$\frac{3}{8}$ "	0.507
BB	$\frac{1}{2}$ "	19 T.P.I. Whit. Form 0.60 O/D	$\frac{1}{2}$ "	0.32	0.40	2.41	0.60	0.88	1.06	1.26	0.815	0.820	$\frac{1}{2}$ "	$\frac{1}{4}$ "	0.589
C	$\frac{3}{4}$ "	$\frac{1}{2}$ "	$\frac{1}{2}$ "	0.32	0.42	2.64	0.60	0.95	1.16	1.36	0.915	0.920	$\frac{3}{4}$ "	$\frac{1}{2}$ "	0.645
CC	$\frac{1}{2}$ "	14 T.P.I. Whit. Form 0.75 O/D	$\frac{1}{2}$ "	0.32	0.47	2.83	0.68	1.05	1.28	1.51	1.002	1.010	$\frac{1}{2}$ "	$\frac{1}{4}$ "	0.736
D	$\frac{3}{4}$ "	$\frac{1}{2}$ "	$\frac{1}{2}$ "	0.32	0.48	2.99	0.73	1.14	1.43	1.66	1.002	1.010	$\frac{3}{4}$ "	$\frac{1}{2}$ "	0.811

Brown Brothers Engineering Ltd

AGS 1137 BANJO BOLT with Union Head Connection

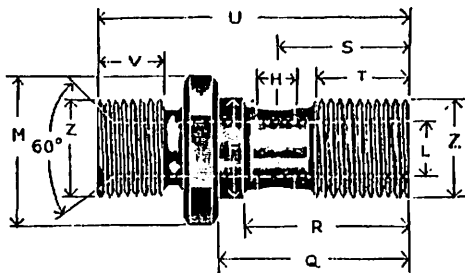

Material : H.T. STEEL

(CADMIUM)

Working Pressures :

3000 lb./sq. in. for sizes up to $\frac{1}{2}$ " B.S.P.
500 lb./sq. in. for sizes $\frac{1}{8}$ " to 1" B.S.P.

ITEM	O/D OF PIPE	Z	V	U	T	S	R	Q	HEX. M		L	H	F
									A/F	MIN.			
A	1 1/2	1/2	0.35	1.75	0.53	0.72	0.83	1.01	0.595	0.600	1/2	1/2	0.375
B	1	1/4	0.35	1.90	0.53	0.75	0.93	1.11	0.705	0.710	1/2	1/2	0.507
BB	1/2	19 T.P.I. Whit. Form 0.60 O/D	0.40	2.09	0.60	0.88	1.06	1.26	0.815	0.820	1/2	1/2	0.589
C	1/2		0.40	2.19	0.60	0.95	1.16	1.36	0.915	0.920	1/2	1/2	0.645
CC	1/2	14 T.P.I. Whit. Form 0.75 O/D	0.45	2.53	0.68	1.05	1.28	1.51	1.002	1.010	1/2	1/2	0.736
D	1/2		0.53	2.71	0.73	1.14	1.43	1.66	1.002	1.010	1/2	1/2	0.811
E	1/2		0.55	2.85	0.73	1.20	1.53	1.76	1.092	1.100	1/2	1/2	0.888
F	1/2		0.55	3.05	0.83	1.33	1.68	1.96	1.292	1.300	1/2	1/2	1.027
G	1/2		0.65	3.40	0.88	1.48	1.88	2.16	1.382	1.390	1/2	1/2	1.175
H	1	1	0.70	3.89	0.97	1.72	2.22	2.54	1.658	1.670	1/2	1/2	1.291

AGS 1138 & 1139 JOINTING WASHERS

AGS 1138 Material :
ALUMINIUM
(ANODISED)
(SELF)

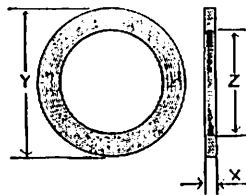

AGS 1139 Material :
COPPER
(CADMIUM)

AGS 1138 :

Working Pressure: 2000 lbs./sq. in. For sizes up to and including $\frac{1}{2}$ " B.S.P.

ITEM	Z	Y	X	IF MADE FROM SHEET	USED WITH B.S.P. THREADS
A	0.39	0.56	0.08	14 S.W.G.	1/2
B	0.52	0.69	0.08	14 S.W.G.	1/2
BB	0.60	0.77	0.08	14 S.W.G.	19 T.P.I. Whit. Form 0.60 O/D
C	0.66	0.83	0.08	14 S.W.G.	1/2
CC	0.75	0.92	0.09	13 S.W.G.	14 T.P.I. Whit. Form 0.75 O/D
D	0.83	1.00	0.09	13 S.W.G.	1/2
E	0.91	1.08	0.09	13 S.W.G.	1/2
F	1.05	1.22	0.09	13 S.W.G.	1/2
G	1.19	1.36	0.09	13 S.W.G.	1/2
H	1.31	1.55	0.12	10 S.W.G.	1/2
J	1.66	1.91	0.12	10 S.W.G.	1/2
K	1.89	2.14	0.12	10 S.W.G.	1/2

Brown Brothers Engineering Ltd

AGS 1140

NIPPLE PLUGS

Material : ALUM. ALLOY

(ANODISED)

Working Pressures :

- 3000 lb./sq. in. for sizes up to $\frac{1}{2}$ " B.S.P.
- 500 lb./sq. in. for sizes $\frac{5}{8}$ " to 1" B.S.P.
- 200 lb./sq. in. for sizes $1\frac{1}{4}$ " and $1\frac{1}{2}$ " B.S.P.

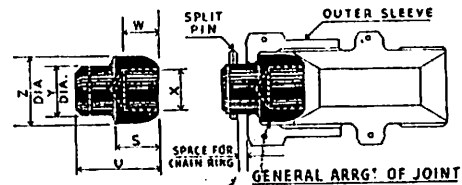

ITEM	B.S.P. THREAD	Z	Y	X	W	U	S	ITEMS REQUIRED TO COMPLETE JOINT	
								OUTER SLEEVE	SPLIT PIN
A	IN. 1/2	IN. 0.30	IN. 0.19	IN. 1/8	IN. 0.250	IN. 0.70	IN. 0.83	AGS 904/A	SP90-C4
B	1/2	0.40	0.25	3/8	0.375	0.86	0.49	AGS 2111	SP90-C5
BB	19 T.P.I. Whit. Form 0.60 O/D	0.40	0.31	3/8	0.375	0.85	0.48	904/BB	SP90-C5
C	1/2	0.55	0.37	1/2	0.375	0.91	0.54	904/C	SP90-C5
CC	14 T.P.I. Whit. Form 0.75 O/D	0.61	0.44	1/2	0.375	0.91	0.54	904/CC	SP90-C7
D	1/2	0.69	0.50	5/8	0.375	0.85	0.48	904/D	SP90-C7
E	1	0.78	0.82	0.562	0.420	0.87	0.50	904/E	SP90-C4
F	1/2	0.92	0.75	0.672	0.420	0.87	0.50	904/F	SP90-C4
G	1/2	1.06	0.87	0.812	0.420	0.87	0.50	904/G	SP90-C4
H	1	1.16	1.00	0.844	0.420	0.87	0.50	904/H	SP90-C4
J	1 1/4	1.50	1.25	1.125	0.420	0.87	0.50	904/J	SP90-C4
K	1 1/2	1.73	1.50	1.400	0.650	1.10	0.78	904/K	SP90-C4

NOTE: Items A—D as shown.
Items E—K have flat bottom holes drilled at each end.

Brown Brothers Engineering Ltd

AGS 1142

ADAPTOR NIPPLE

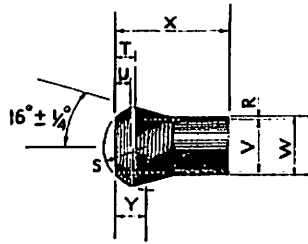

Material : STEEL (CADMIUM)

Working Pressures :

3000 lb./sq. in. for sizes up to 1/2" B.S.P.
 500 lb./sq. in. for sizes 3/8" to 1" B.S.P.
 200 lb./sq. in. for sizes 1 1/4" to 2" B.S.P.
 100 lb./sq. in. for size 2 1/2" B.S.P.

ITEM	O/D OF PIPE	Y		X		W		V		U	T	S	R	SUITABLE FOR PIPES S.W.G.
		IN.	IN.	IN.	IN.	IN.	IN.	IN.	IN.					
A	3/8	0.10	0.70	0.118	0.181	0.065	0.105	0.134	0.016	22 & 24				
B	1/2	0.14	0.85	0.181	0.270	0.070	0.110	0.20	0.016	22 & 24				
BB	3/8	0.17	0.90	0.227	0.352	0.070	0.110	0.24	0.016	20 & 22				
C	1/2	0.19	0.95	0.290	0.415	0.100	0.140	0.27	0.017	20 & 22				
CC	3/8	0.21	1.00	0.352	0.540	0.110	0.160	0.30	0.017	20 & 22				
D	1/2	0.22	1.02	0.415	0.666	0.115	0.155	0.33	0.017	20 & 22				
E	3/4	0.29	1.07	0.540	0.789	0.140	0.180	0.41	0.017	20 & 22				
F	1/2	0.30	1.10	0.666	0.914	0.175	0.215	0.46	0.018	20 & 22				
G	3/4	0.37	1.15	0.789	1.100	0.160	0.200	0.56	0.018	20 & 22				
H	1	0.36	1.20	0.914	1.350	0.160	0.210	0.61	0.018	20 & 22				
J	1 1/4	0.48	1.30	1.163	1.780	0.170	0.230	0.77	0.025	20 & 22				
K	1 1/2	0.55	1.45	1.412	1.852	0.190	0.250	0.91	0.030	20 & 22				
M	2	0.67	2.00	1.852	2.200	0.200	0.260	1.170	0.035	18 & 16				
P	2 1/2	0.83	2.00	2.302	2.200	0.200	0.260	1.610	0.040	18 & 16				

AGS 1143

CONE PLUGS

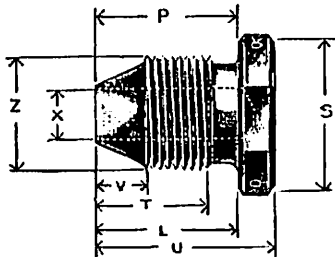

Material : ALUM. ALLOY

(ANODISED)

Working Pressures :

3000 lb./sq. in. for sizes up to 1/2" B.S.P.
 500 lb./sq. in. for sizes 3/8" to 1" B.S.P.
 200 lb./sq. in. for sizes 1 1/4" and 1 1/2" B.S.P.

ITEM	O/D OF PIPE	Z B.S.P. THREAD	X DRILL	V	U	T	S ACROSS FLATS		P DRILL LENGTH	L
							MAX.	MIN.		
A	3/8	19 T.P.I.	3/16	0.22	0.96	0.67	0.525	0.520	0.7	0.70
B	1/2	19 T.P.I.	3/16	0.28	1.05	0.62	0.600	0.595	0.8	0.80
BB	3/8	Whit. Form 0.60 O/D	3/16	0.32	1.15	0.72	0.710	0.705	0.85	0.90
C	1/2	Whit. Form 0.60 O/D	3/16	0.32	1.15	0.72	0.820	0.815	0.85	0.90
CC	3/8	14 T.P.I.	5/16	0.32	1.30	0.78	0.920	0.915	0.95	1.02
D	1/2	14 T.P.I.	5/16	0.32	1.30	0.78	1.010	1.002	0.95	1.02
E	3/4	14 T.P.I.	5/16	0.32	1.35	0.81	1.10	1.092	1.0	1.05
F	1/2	14 T.P.I.	5/16	0.32	1.40	0.86	1.20	1.192	1.0	1.10
G	3/4	14 T.P.I.	5/16	0.32	1.60	0.91	1.39	1.382	1.0	1.15
H	1	14 T.P.I.	5/16	0.34	1.50	0.87	1.67	1.658	1.0	1.15
J	1 1/4	14 T.P.I.	1 1/4	0.34	1.50	0.82	2.05	2.035	1.0	1.10
K	1 1/2	14 T.P.I.	1 1/4	0.34	1.65	0.97	2.22	2.20	1.0	1.25

Brown Brothers Engineering Ltd

AGS 1144 BULKHEAD UNION BODIES (HEXAGON)

(General Arrangement)

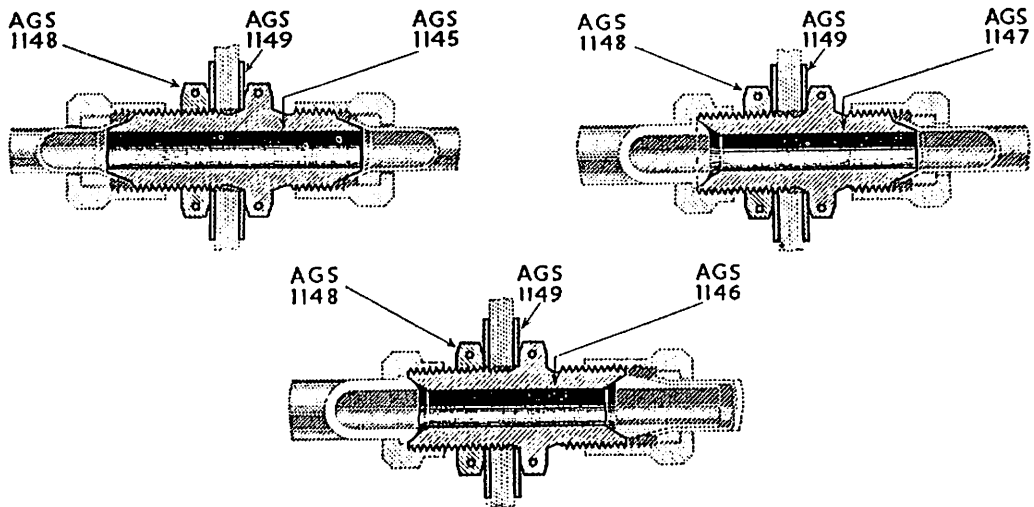

FOR USE WITH BULKHEADS NOT EXCEEDING 0.25" THICK

OUTSIDE DIA. OF PIPES .	$\frac{3}{4}$ "	$\frac{1}{2}$ "	$\frac{3}{8}$ "	$\frac{1}{2}$ "	$\frac{3}{4}$ "	$\frac{1}{2}$ "	$\frac{1}{2}$ "	$\frac{3}{4}$ "	$\frac{1}{2}$ "	$\frac{1}{2}$ "	$\frac{1}{2}$ "	$\frac{1}{2}$ "
WASHERS ITEM	1	2	3	4	6	6	7	8	9	10	11	12
DIA. OF HOLE IN BULKHEAD .	$\frac{11}{16}$ "	$\frac{11}{16}$ "	$\frac{1}{2}$ "	$\frac{11}{16}$ "	$\frac{3}{4}$ "	$\frac{3}{4}$ "	$\frac{3}{4}$ "	$1\frac{1}{16}$ "	$1\frac{3}{16}$ "	$1\frac{1}{4}$ "	$1\frac{1}{8}$ "	$1\frac{1}{8}$ "

AGS 1145 UNION BODY

Material : ALUM. ALLOY

(ANODISED)

Working Pressure :

3000 lb./sq. in. for sizes up to $\frac{1}{2}$ " B.S.P.

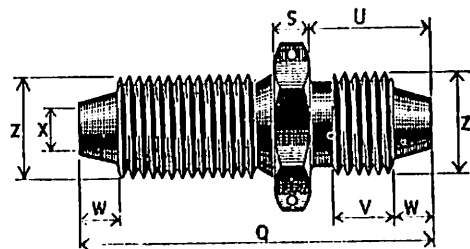

ITEM	O/D OF PIPES	Z	X	W	FULL V THREAD	U	S	Q	HEXAGON ACROSS FLATS	
									H.S.P. THREAD	DIA. BORE
A	$\frac{1}{8}$ "	$\frac{1}{2}$	$\frac{1}{8}$	0.22	0.36	0.72	0.25	2.21	0.595	0.600
B	$\frac{1}{4}$	$\frac{1}{2}$	$\frac{1}{4}$	0.28	0.39	0.86	0.26	2.47	0.705	0.710
BB	$\frac{3}{8}$	$\frac{1}{2}$	$\frac{3}{8}$	0.32	0.40	0.91	0.26	2.59	0.815	0.820
C	$\frac{1}{2}$	$\frac{1}{2}$	$\frac{1}{2}$	0.32	0.42	0.93	0.27	2.67	0.915	0.920
CC	$\frac{3}{4}$	$\frac{1}{2}$	$\frac{3}{4}$	0.32	0.47	1.01	0.28	2.83	1.002	1.010
D	$\frac{1}{2}$	$\frac{1}{2}$	$\frac{1}{2}$	0.32	0.48	1.03	0.28	2.87	1.092	1.100

Brown Brothers Engineering Ltd

AGS 1146

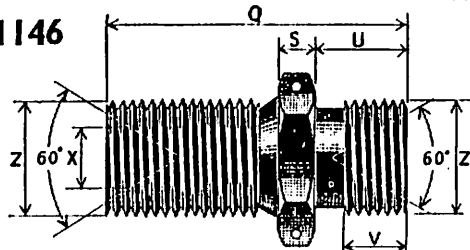

UNION BODY

Material: ALUM. ALLOY

(ANODISED)

Working Pressures:

3000 lb./sq. in. for sizes up to $\frac{1}{2}$ " B.S.P.
 500 lb./sq. in. for sizes $\frac{3}{8}$ " to 1" B.S.P.
 200 lb./sq. in. for sizes $1\frac{1}{4}$ " & $1\frac{1}{2}$ " B.S.P.

ITEM	DIAM. OF PIPES	Z	X	FULL V THREAD	U	S	Q	HEXAGON ACROSS FLATS	
		B.S.P. THREAD	DIA. BORE					MIN.	MAX.
A	$\frac{1}{8}$ "	$\frac{1}{8}$ "	$\frac{1}{8}$ "	IN. 0.33	IN. 0.47	IN. 0.26	IN. 1.70	IN. 0.595	IN. 0.600
B	$\frac{1}{4}$ "	$\frac{1}{4}$ "	$\frac{1}{4}$ "	0.35	0.52	0.25	1.81	0.705	0.710
BB	$\frac{3}{8}$ "	19 T.P.I. Whit. Form 0.60 o/d	$\frac{3}{8}$ "	0.40	0.57	0.25	1.92	0.815	0.820
C	$\frac{1}{2}$ "	$\frac{1}{2}$ "	$\frac{1}{2}$ "	0.40	0.59	0.27	1.96	0.915	0.920
CC	$\frac{5}{8}$ "	14 T.P.I. Whit. Form 0.75 o/d	$\frac{5}{8}$ "	0.45	0.67	0.28	2.14	1.002	1.010
D	$\frac{3}{4}$ "	$\frac{3}{4}$ "	$\frac{3}{4}$ "	0.53	0.75	0.28	2.31	1.092	1.100
E	$\frac{7}{8}$ "	$\frac{7}{8}$ "	$\frac{7}{8}$ "	0.55	0.78	0.30	2.40	1.292	1.300
F	1"	1"	1"	0.55	0.78	0.30	2.40	1.382	1.390
G	1"	1"	1"	0.66	0.88	0.35	2.65	1.658	1.670
H	1"	1"	1"	0.70	0.98	0.35	2.90	1.845	1.860
J	1 $\frac{1}{4}$ "	1 $\frac{1}{4}$ "	1 $\frac{1}{4}$ "	0.70	0.98	0.40	2.95	2.200	2.220
K	1 $\frac{1}{2}$ "	1 $\frac{1}{2}$ "	1 $\frac{1}{2}$ "	0.70	0.98	0.40	2.95	2.555	2.580

AGS 1147

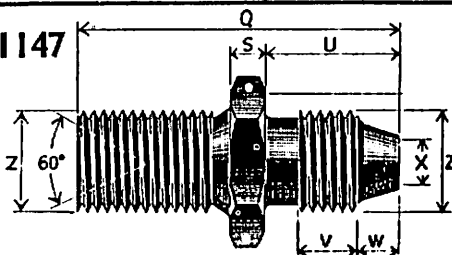

UNION BODY

Material: ALUM. ALLOY

(ANODISED)

Working Pressure:

3000 lb./sq. in. for sizes up to $\frac{1}{2}$ " B.S.P.

ITEM	DIAM. OF PIPES	Z	X	W	FULL V THREAD	U	S	Q	HEXAGON ACROSS FLATS	
		B.S.P. THREAD	DIA. BORE						MIN.	MAX.
A	$\frac{1}{8}$ "	$\frac{1}{8}$ "	$\frac{1}{8}$ "	IN. 0.23	IN. 0.36	IN. 0.72	IN. 0.25	IN. 1.94	IN. 0.595	IN. 0.60
B	$\frac{1}{4}$ "	$\frac{1}{4}$ "	$\frac{1}{4}$ "	0.28	0.39	0.85	0.25	2.13	0.705	0.71
BB	$\frac{3}{8}$ "	19 T.P.I. Whit. Form 0.60 o/d	$\frac{3}{8}$ "	0.32	0.40	0.91	0.25	2.25	0.815	0.82
C	$\frac{1}{2}$ "	$\frac{1}{2}$ "	$\frac{1}{2}$ "	0.32	0.42	0.93	0.27	2.29	0.915	0.92
CC	$\frac{5}{8}$ "	14 T.P.I. Whit. Form 0.75 o/d	$\frac{5}{8}$ "	0.32	0.47	1.01	0.28	2.47	1.002	1.01
D	$\frac{3}{4}$ "	$\frac{3}{4}$ "	$\frac{3}{4}$ "	0.32	0.48	1.03	0.28	2.68	1.092	1.10

Brown Brothers Engineering Ltd

AGS 1148

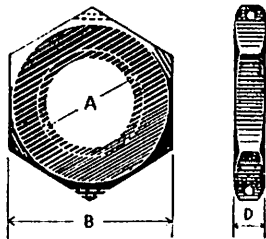

Material :
ALUM. ALLOY
(ANODISED)

THIN NUTS

ITEM	A	B		D
	B.S.P. THREAD	MIN.	MAX.	
A	IN. $\frac{1}{8}$	IN. 0.595	IN. 0.60	IN. 0.19
B	$\frac{1}{4}$	0.705	0.71	0.22
BB	19 T.P.I. Whit. Form 0.60 o/d	0.815	0.82	0.22
C	$\frac{3}{8}$	0.915	0.92	0.22
CC	14 T.P.I. Whit. Form 0.75 o/d	1.002	1.01	0.25
D	$\frac{1}{2}$	1.092	1.10	0.25
E	$\frac{5}{8}$	1.292	1.30	0.25
F	$\frac{3}{4}$	1.382	1.39	0.25
G	$\frac{7}{8}$	1.658	1.67	0.25
H	1	1.845	1.86	0.30
J	1 $\frac{1}{4}$	2.20	2.22	0.30
K	1 $\frac{1}{2}$	2.655	2.68	0.30

AGS 1149

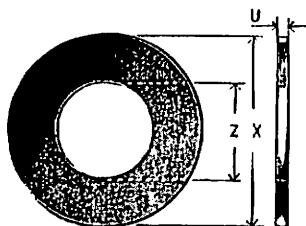

Material :
ALUMINIUM
(SELF)

WASHER PLATES

ITEM	Z	X	U
			S.W.G.
1	IN. 0.40	IN. 1.00	18
2	0.53	1.15	18
3	0.61	1.35	18
4	0.67	1.40	18
5	0.76	1.55	18
6	0.84	1.65	18
7	0.92	1.90	16
8	1.06	2.05	16
9	1.20	2.40	16
10	1.32	2.65	16
11	1.67	3.05	16
12	1.90	3.50	16

AGS 1159

CONE CAPS

Material : ALUMINIUM ALLOY (ANODISED)
Replaced by AGS 1236

Brown Brothers Engineering Ltd

AGS 1165 90° NIPPLE ELBOW (END CONNECTION)

Protection Plug AGS 595

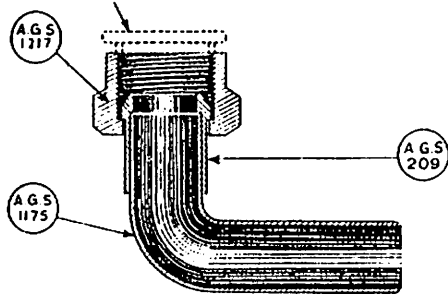

ITEM	TO SUIT HOSE BORE	COMPONENT PARTS		
		A.G.S. 1217 ITEM	A.G.S. 209 ITEM	A.G.S. 1175 ITEM
B	IN. $\frac{1}{4}$	B	B	B
C	$\frac{3}{8}$	C	D	C
D	$\frac{1}{2}$	D	F	D
E	$\frac{5}{8}$	E	H	E
F	$\frac{3}{4}$	F	J	F
G	$\frac{7}{8}$	G	K	G
H	1	H	L	H
J	1 $\frac{1}{4}$	J	M	J
K	1 $\frac{1}{2}$	K	N	K

AGS 1166 45° NIPPLE ELBOW (END CONNECTION)

Protection Plug AGS 595

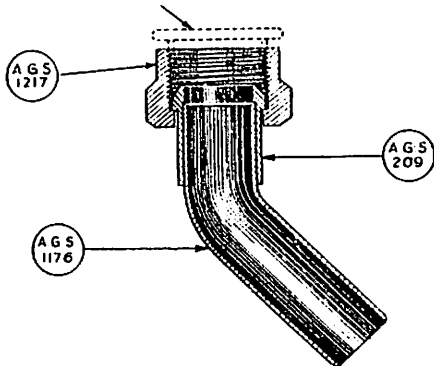

ITEM	TO SUIT HOSE BORE	COMPONENT PARTS		
		A.G.S. 1217 ITEM	A.G.S. 209 ITEM	A.G.S. 1176 ITEM
B	IN. $\frac{1}{4}$	B	B	B
C	$\frac{3}{8}$	C	D	C
D	$\frac{1}{2}$	D	F	D
E	$\frac{5}{8}$	E	H	E
F	$\frac{3}{4}$	F	J	F
G	$\frac{7}{8}$	G	K	G
H	1	H	L	H
J	1 $\frac{1}{4}$	J	M	J
K	1 $\frac{1}{2}$	K	N	K

Brown Brothers Engineering Ltd

AGS 1167

90° UNION ELBOW

ITEM	THREAD	NUT A.G.S. 1217 ITEM	NIPPLE A.G.S. 209 ITEM	UNION SLEEVE A.G.S. 1169 ITEM	TUBE A.G.S. 1177 ITEM	TEST PRESSURE LB./SQ. IN.
A	1/2 IN. B.S.P.	A	A	A	A	3,750
B	1/2 B.S.P.	B	B	B	B	3,750
BB	19 T.P.I. Whit. Form 0.60 O/D	BB	BB	BB	BB	3,750
C	1/2 B.S.P.	C	D	C	C	3,750
CC	14 T.P.I. Whit. Form 0.75 O/D	CC	DD	CC	CC	3,750
D	1/2 B.S.P.	D	F	D	D	3,750
E	1/2 B.S.P.	E	H	E	E	750
F	1/2 B.S.P.	F	J	F	F	750
G	1/2 B.S.P.	G	K	G	G	750
H	1 B.S.P.	H	L	H	H	750
J	1 1/4 B.S.P.	J	M	J	J	300
K	1 1/2 B.S.P.	K	N	K	K	300

Protection Plug AGS 595

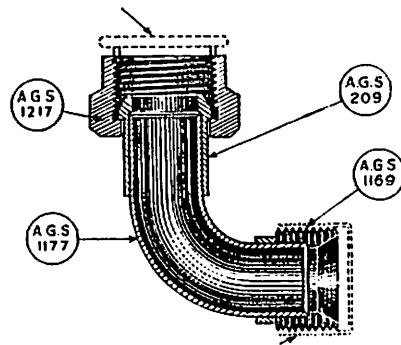

Protection Cap AGS 597

AGS 1168

45° UNION ELBOW

ITEM	THREAD	NUT A.G.S. 1217 ITEM	NIPPLE A.G.S. 209 ITEM	UNION SLEEVE A.G.S. 1169 ITEM	TUBE A.G.S. 1178 ITEM	TEST PRESSURE LB./SQ. IN.
A	1/2 IN. B.S.P.	A	A	A	A	3,750
B	1/2 B.S.P.	B	B	B	B	3,750
BB	19 T.P.I. Whit. Form 0.60 O/D	BB	BB	BB	BB	3,750
C	1/2 B.S.P.	C	D	C	C	3,750
CC	14 T.P.I. Whit. Form 0.75 O/D	CC	DD	CC	CC	3,750
D	1/2 B.S.P.	D	F	D	D	3,750
E	1/2 B.S.P.	E	H	E	E	750
F	1/2 B.S.P.	F	J	F	F	750
G	1/2 B.S.P.	G	K	G	G	750
H	1 B.S.P.	H	L	H	H	750
J	1 1/4 B.S.P.	J	M	J	J	300
K	1 1/2 B.S.P.	K	N	K	K	300

Protection Plug AGS 595

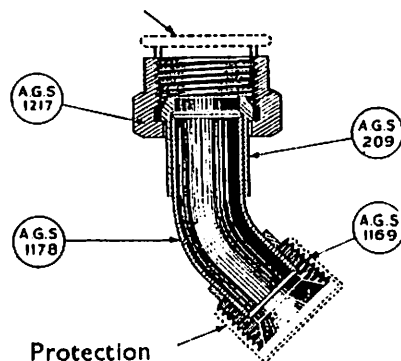

Protection Cap AGS 597

Brown Brothers Engineering Ltd

AGS 1169

UNION SLEEVE

ITEM	DIA. OF PIPE	Z	X	W	V	U	S	T
		B.S.P. Thread	Dia. Drill					
A	IN. $\frac{3}{16}$	IN. $\frac{1}{8}$	IN. $\frac{1}{8}$	IN. $\frac{1}{16}$	IN. 0.35	IN. 0.63	IN. 0.30	IN. 0.30
B	$\frac{1}{2}$	$\frac{1}{2}$	$\frac{1}{8}$	$\frac{1}{4}$	0.35	0.65	0.37	0.37
BB	$\frac{1}{2}$	10 T.P.I. Whit. Form 0.60 O/D	$\frac{1}{2}$	$\frac{5}{16}$	0.40	0.70	0.43	0.42
C	$\frac{1}{2}$	$\frac{1}{2}$	$\frac{5}{16}$	$\frac{1}{2}$	0.40	0.74	0.49	0.45
CC	$\frac{1}{2}$	14 T.P.I. Whit. Form 0.75 O/D	$\frac{1}{2}$	$\frac{3}{8}$	0.45	0.83	0.55	0.55
D	$\frac{1}{2}$	$\frac{1}{2}$	$\frac{3}{8}$	$\frac{1}{2}$	0.50	0.90	0.62	0.60
E	$\frac{1}{2}$	$\frac{1}{2}$	$\frac{3}{8}$	$\frac{1}{2}$	0.55	0.75	0.75	0.50
F	$\frac{1}{2}$	$\frac{1}{2}$	$\frac{1}{2}$	$\frac{1}{2}$	0.61	0.81	0.88	0.54
G	$\frac{1}{2}$	$\frac{1}{2}$	$\frac{1}{2}$	$\frac{1}{2}$	0.65	0.85	1.00	0.57
H	1	1	$\frac{1}{2}$	1	0.65	0.85	1.13	0.60
J	$1\frac{1}{2}$	$1\frac{1}{2}$	$1\frac{1}{4}$	$1\frac{1}{2}$	0.65	0.85	1.38	0.54
K	$1\frac{1}{2}$	$1\frac{1}{2}$	$1\frac{1}{4}$	$1\frac{1}{2}$	0.70	0.90	1.63	0.61
L	$1\frac{1}{2}$	$1\frac{1}{2}$	$1\frac{1}{4}$	$1\frac{1}{2}$	0.70	0.90	1.90	0.61
M	2	2	$1\frac{1}{2}$	2	0.75	0.95	2.15	0.61

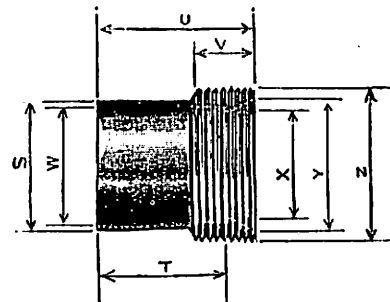

Material: BRASS
(SELF FINISH)

AGS 1170

NIPPLE

Items D, G, H and J cancelled. Replaced by AGS 2120

ITEM	O/D OF PIPE	X	W	V	U	T	R
				Bore			Min.
A	IN. $\frac{3}{16}$	IN. 0.70	IN. 0.118	IN. $\frac{1}{16}$	IN. 0.142	IN. 0.192	IN. 0.016
B	$\frac{1}{2}$	0.85	0.181	$\frac{1}{8}$	0.185	0.235	0.016
BB	$\frac{1}{2}$	0.90	0.227	$\frac{3}{16}$	0.235	0.285	0.016
C	$\frac{1}{2}$	0.95	0.290	$\frac{1}{2}$	0.235	0.285	0.017
CC	$\frac{1}{2}$	1.00	0.352	$\frac{3}{8}$	0.235	0.285	0.017
D							
E	$\frac{1}{2}$	1.05	0.540	$\frac{1}{2}$	0.235	0.285	0.017
F	$\frac{1}{2}$	1.11	0.665	$\frac{1}{2}$	0.235	0.285	0.018
G							
H							
J							
K	$1\frac{1}{2}$	1.45	1.412	1.350	0.285	0.335	0.030
M	2	2.25	1.852	1.780	0.425	0.625	0.035
P	$2\frac{1}{2}$	2.45	2.302	2.220	0.570	0.670	0.040

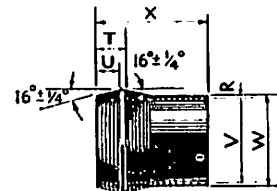

Material: STEEL
(CADMIUM)

Working Pressures:
3000 lb./sq. in. for sizes $\frac{3}{16}$ " to $\frac{1}{2}$ " B.S.P.
500 lb./sq. in. for sizes $\frac{3}{8}$ " to 1" B.S.P.
200 lb./sq. in. for sizes $1\frac{1}{2}$ " to 2" B.S.P.
100 lb./sq. in. for size $2\frac{1}{2}$ " B.S.P.

Brown Brothers Engineering Ltd

AGS 1173 & 1220

BANJO BOLT

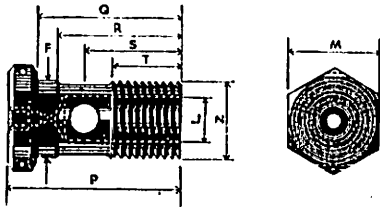

Material: AGS 1173 .H.T STEEL
(CADMIUM)

AGS 1220 ALUMINIUM ALLOY
(ANODISED)

Working Pressures:

3,000 lb./sq. in. for sizes up to $\frac{1}{2}$ " B.S.P.

500 lb./sq. in. for sizes $\frac{3}{8}$ " to 1" B.S.P.

ITEM	O/D OF PIPE	Z B.S.P. Thread	T	S	R	Q	P	N	M		L Drill	F
									Min.	Max.		
A	$\frac{1}{8}$ "	$\frac{1}{8}$ "	IN. 0.53	IN. 0.72	IN. 0.83	IN. 1.01	IN. 1.36	IN. 0.81	IN. 0.595	IN. 0.600	IN. $\frac{1}{8}$ "	IN. 0.375
B	$\frac{1}{4}$ "	$\frac{1}{4}$ "	0.53	0.75	0.93	1.11	1.44	0.87	0.705	0.710	$\frac{3}{16}$ "	0.507
BB	$\frac{1}{4}$ "	19 T.P.I. Whit. Form 0.60 O/D	0.60	0.88	1.06	1.26	1.60	1.00	0.815	0.820	$\frac{5}{16}$ "	0.589
C	$\frac{1}{2}$ "	$\frac{1}{2}$ "	0.60	0.95	1.16	1.86	1.70	1.00	0.915	0.920	$\frac{1}{2}$ "	0.645
CC	$\frac{1}{2}$ "	14 T.P.I. Whit. Form 0.75 O/D	0.68	1.05	1.28	1.61	1.85	1.21	1.002	1.010	$\frac{1}{2}$ "	0.736
D	$\frac{3}{4}$ "	$\frac{3}{4}$ "	0.73	1.14	1.43	1.66	1.98	1.32	1.002	1.010	$\frac{3}{4}$ "	0.811
E	$\frac{7}{8}$ "	$\frac{7}{8}$ "	0.73	1.20	1.53	1.76	2.10	1.43	1.092	1.100	$\frac{7}{8}$ "	0.888
F	1"	1"	0.83	1.33	1.68	1.96	2.31	1.60	1.202	1.300	$\frac{1}{2}$ "	1.027
G	$\frac{1}{2}$ "	$\frac{1}{2}$ "	0.88	1.48	1.88	2.16	2.55	1.80	1.382	1.390	$\frac{1}{2}$ "	1.175
H	1"	1"	0.97	1.72	2.22	2.64	2.91	2.09	1.658	1.670	$\frac{1}{2}$ "	1.291

AGS 1174

BLEEDER SCREW

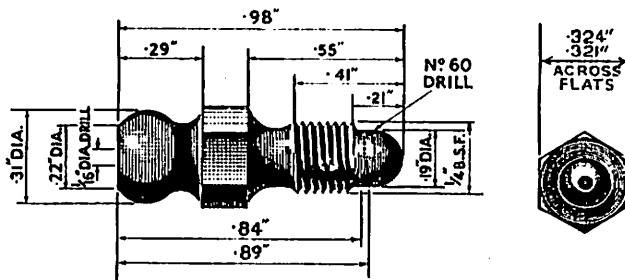

Material :
STEEL
(CADMIUM)

Brown Brothers Engineering Ltd

AGS 1175

90° ELBOW TUBE

Material: STEEL TUBE
(SELF FINISH)

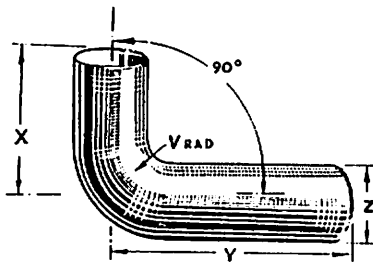

ITEM	Z		Y	X	V
	O.D	SWG			
	IN.		IN.	IN.	IN.
B	$\frac{1}{4}$	20	1.55	0.670	0.300
C	$\frac{3}{8}$	18	2.16	0.860	0.410
D	$\frac{1}{2}$	18	2.41	1.260	0.660
E	$\frac{5}{8}$	17	2.41	1.360	0.660
F	$\frac{3}{4}$	17	2.65	1.725	0.875
G	$\frac{7}{8}$	16	3.00	2.200	1.250
H	1	16	3.00	2.350	1.250
J	1 $\frac{1}{4}$	14	3.25	2.600	1.250
K	1 $\frac{1}{2}$	14	3.50	3.100	1.500

AGS 1176

45° ELBOW TUBE

Material: STEEL TUBE
(SELF FINISH)

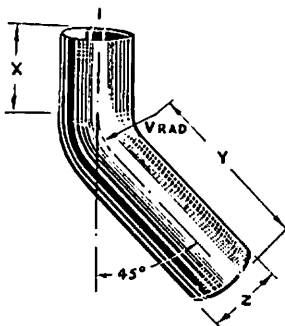

ITEM	Z		Y	X	V
	O/D	SWG			
	IN.		IN.	IN.	IN.
B	$\frac{1}{4}$	20	1.25	0.37	0.300
C	$\frac{3}{8}$	18	1.75	0.45	0.410
D	$\frac{1}{2}$	18	1.75	0.60	0.660
E	$\frac{5}{8}$	17	1.75	0.70	0.660
F	$\frac{3}{4}$	17	1.75	0.85	0.875
G	$\frac{7}{8}$	16	1.75	0.95	1.250
H	1	16	1.75	1.10	1.250
J	1 $\frac{1}{4}$	14	2.00	1.35	1.250
K	1 $\frac{1}{2}$	14	2.00	1.60	1.500

AGS 1177

ELBOW TUBE

ITEM	Z		X	V	T	S
	O/DIA.	SWG				
A	IN. $\frac{3}{8}$	20	IN. 0.55	IN. 0.25	IN. 0.02	IN. 0.55
B	$\frac{1}{2}$	20	0.67	0.30	0.02	0.67
BB	$\frac{5}{8}$	18	0.83	0.41	0.02	0.83
C	$\frac{3}{4}$	18	0.86	0.41	0.02	0.86
CC	$\frac{7}{8}$	18	0.96	0.41	0.02	0.96
D	$\frac{1}{2}$	18	1.26	0.66	0.02	1.26
E	$\frac{3}{4}$	17	1.36	0.66	0.03	1.16
F	$\frac{1}{2}$	17	1.725	0.875	0.03	1.415
G	$\frac{3}{4}$	16	2.20	1.25	0.03	1.82
H	1	16	2.35	1.25	0.03	1.85
J	$1\frac{1}{2}$	14	2.60	1.25	0.04	1.79
K	$1\frac{1}{2}$	14	3.10	1.50	0.04	2.11

**Material : STEEL TUBE
(SELF FINISH)**

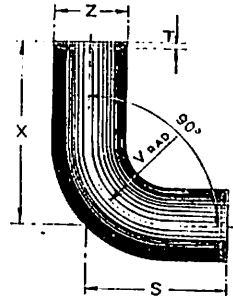

AGS 1178

ELBOW TUBE

ITEM	Z		X	V	S
	O/D	SWG			
A	IN. $\frac{3}{16}$	20	IN. 0.30	IN. 0.25	IN. 0.30
B	$\frac{1}{4}$	20	0.37	0.30	0.37
BB	$\frac{5}{8}$	18	0.42	0.41	0.42
C	$\frac{3}{4}$	18	0.45	0.41	0.45
CC	$\frac{7}{16}$	18	0.55	0.41	0.55
D	$\frac{1}{2}$	18	0.60	0.66	0.60
E	$\frac{3}{8}$	17	0.70	0.66	0.50
F	$\frac{1}{2}$	17	0.85	0.875	0.54
G	$\frac{3}{4}$	16	0.95	1.25	0.57
H	1	16	1.10	1.25	0.60
J	$1\frac{1}{2}$	14	1.35	1.25	0.54
K	$1\frac{1}{2}$	14	1.60	1.50	0.61

**Material : STEEL TUBE
(SELF FINISH)**

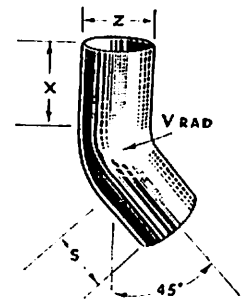

AGS 1185

PIPE COUPLINGS—CONE PLUGS

Material : BRASS (CADMIUM)

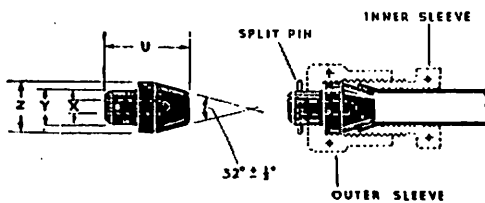

ITEM	O/D OF PIPE	Z	Y	X	U	ITEMS REQUIRED TO COMPLETE JOINT	
						OUTER SLEEVE	SPLIT PIN
BB	IN. $\frac{3}{8}$	IN. 0.49	IN. 0.31	IN. Not Drilled	IN. 0.85	AGS 904/BB	SP9C6
C	$\frac{1}{2}$	0.55	0.37	$\frac{3}{8}$	0.91	AGS 904/C	SP9C6

Brown Brothers Engineering Ltd

AGS 1186

BONDED SEALS

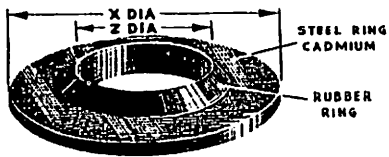

STEEL AND RUBBER RINGS BONDED TOGETHER

ITEM	NOM. DIA. OR THREAD	%		ITEM	NOM. DIA. OR THREAD	Z	
		IN.	IN.			IN.	IN.
1	6 B.A.	0.115 0.125	0.250 0.255	13	1 1/8"	0.950 0.960	1.310 1.315
2	4 B.A.	0.157 0.167	0.286 0.291	F	1" B.S.P.F.	1.060 1.068	1.375 1.380
3	2 B.A.	0.200 0.210	0.330 0.335	FF	1 1/8"	1.090 1.100	1.520 1.525
4	1/2"	0.205 0.275	0.520 0.525	14	1 1/2"	1.150 1.160	1.440 1.445
5	1/2"	0.270 0.280	0.525 0.530	G	1 1/2" B.S.P.F.	1.208 1.216	1.500 1.505
6	3/8"	0.322 0.330	0.525 0.530	15	1 1/2"	1.280 1.290	1.630 1.635
7	3/8"	0.335 0.345	0.560 0.565	H	1" B.S.P.F.	1.329 1.337	1.685 1.690
A	1/2" B.S.P.F.	0.403 0.411	0.625 0.630	16	1 1/2"	1.410 1.420	1.750 1.755
8	0.40"	0.438 0.442	0.723 0.727	17	1 1/2"	1.530 1.540	1.880 1.885
9	1/4"	0.455 0.465	0.750 0.755	J	1 1/2" B.S.P.F.	1.685 1.693	2.062 2.067
B	1/2" B.S.P.F.	0.536 0.544	0.810 0.815	18	1 1/2"	1.780 1.790	2.250 2.255
10	1/4"	0.580 0.590	0.875 0.880	K	1 1/2" B.S.P.F.	1.902 1.910	2.307 2.312
BB	19 T.P.I. 0.60% WHIT. B.S.84	0.618 0.626	0.875 0.880	19	2"	2.030 2.040	2.500 2.505
11	1/2"	0.645 0.655	1.000 1.005	L	1 1/2" B.S.P.F.	2.156 2.164	2.750 2.755
C	1/2" B.S.P.F.	0.675 0.683	0.937 0.942	LL	2 1/4"	2.280 2.290	2.770 2.775
12	1/2"	0.710 0.720	1.000 1.005	M	2" B.S.P.F.	2.380 2.390	2.875 2.880
CG	14 T.P.I. 75% WHIT. B.S.84	0.770 0.778	1.060 1.065	MM	2 1/4"	2.530 2.540	3.000 3.005
D	1/2" B.S.P.F.	0.843 0.851	1.125 1.130	N	2 1/4" B.S.P.F.	2.620 2.630	3.130 3.135
E	1/2" B.S.P.F.	0.920 0.928	1.250 1.255	P	2 1/4" B.S.P.F.	2.990 3.000	3.555 3.560

Brown Brothers Engineering Ltd

AGS 1187
(ALUM. ALLOY)
(ANODISED)

UNION NUT

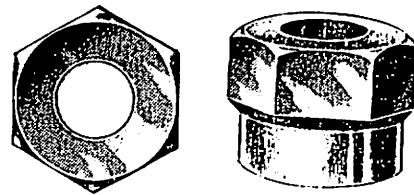

Details and Prices on Application

AGS 1193 & AGS 1194 PIPE COUPLINGS

FLANGED BULKHEAD UNION BODY

Material : BRASS

Working Pressure: 3,000 lb./sq. in.

For arrangement of pipe joints, see AGS 1110

AGS 1195 PIPE COUPLINGS—CONE TEE

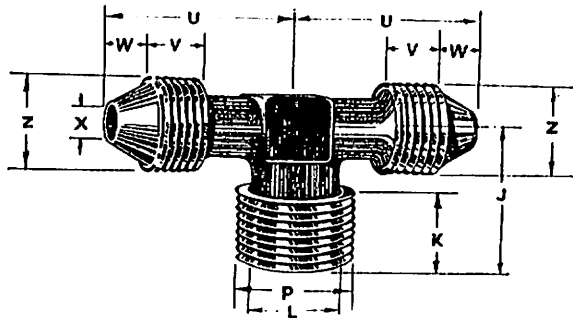

Material : BRASS

(CADMIUM)

Working Pressure: 3,000 lb./sq. in. for sizes up to $\frac{1}{2}$ " B.S.P.

ITEM	DIA. OF PIPES	DIMENSIONS FOR EQUAL BRANCHES				DIMENSIONS FOR REMAINING BRANCH							
		Z	X	W	V	U	P	J	K				
		B.S.P. THREAD	DIA. DRILL					B.S.P. THREAD	DIA. DRILL				
1	$\frac{1}{8} \times \frac{1}{8} \times \frac{1}{8}$	$\frac{1}{8}$	$\frac{1}{16}$	$\frac{1}{8}$	$\frac{1}{8}$	$\frac{1}{8}$	$\frac{1}{8}$	$\frac{1}{8}$	$\frac{1}{8}$	$\frac{1}{8}$	$\frac{1}{8}$	$\frac{1}{8}$	$\frac{1}{8}$
2	$\frac{1}{4} \times \frac{1}{4} \times \frac{1}{4}$	$\frac{1}{4}$	$\frac{1}{8}$	$\frac{1}{4}$	$\frac{1}{4}$	$\frac{1}{4}$	$\frac{1}{4}$	$\frac{1}{4}$	$\frac{1}{4}$	$\frac{1}{4}$	$\frac{1}{4}$	$\frac{1}{4}$	$\frac{1}{4}$
3	$\frac{1}{8} \times \frac{1}{8} \times \frac{1}{8}$	19 T.P.L. Whit. form 0-60° O/D	LETTR. "B" 0-238°	$\frac{1}{8}$	$\frac{1}{8}$	$\frac{1}{8}$	$\frac{1}{8}$	$\frac{1}{8}$	$\frac{1}{8}$	$\frac{1}{8}$	$\frac{1}{8}$	$\frac{1}{8}$	$\frac{1}{8}$
4	$\frac{1}{8} \times \frac{1}{8} \times \frac{1}{8}$	19 T.P.L. Whit. form 0-60° O/D	LETTR. "B" 0-238°	$\frac{1}{8}$	$\frac{1}{8}$	$\frac{1}{8}$	$\frac{1}{8}$	$\frac{1}{8}$	$\frac{1}{8}$	$\frac{1}{8}$	$\frac{1}{8}$	$\frac{1}{8}$	$\frac{1}{8}$

Brown Brothers Engineering Ltd

AGS 1196 UNION 4-WAY PIECE (Unequal)
Material: BRASS

AGS 1197 NIPPLE PLUGS
Material: BRASS

AGS 1198 CONE TEE (Equal)
Material: BRASS

AGS 1199 UNION TEE (Unequal)
Material: BRASS

AGS 1213 BANJO BOLT

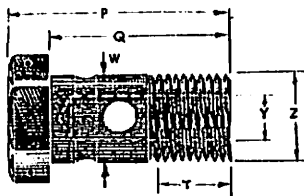

Material : LIGHT ALLOY
(ANODISED)

Working Pressures :
3,000 lb./sq. in. for sizes up to 1/2" B.S.P.
500 lb./sq. in. for sizes 5/8" to 1" B.S.P.

ITEM	O/D OF PIPE	Z B.S.P. THREAD	Y DIA. DRILL	W	T MIN. FULL THD.	Q	P	M	
								MIN.	MAX.
A	IN. 1/8	IN. 1/8	IN. 3/16	IN. 0.375	IN. 0.43	IN. 1.01	IN. 1.36	0.595	0.600
B	1/4	1/4	5/16	0.507	0.45	1.11	1.44	0.705	0.710
BB	1/8	19 T.P.I. Whit. form 0.60" O/D	3/16	0.589	0.45	1.26	1.60	0.815	0.820
C	3/8	3/8	1/8	0.645	0.49	1.36	1.70	0.915	0.920
CC	7/8	14 T.P.I. Whit. form 0.75" O/D	3/16	0.736	0.52	1.51	1.85	1.002	1.010
D	1/2	1/2	7/16	0.811	0.59	1.66	1.98	1.002	1.010
E	5/8	5/8	1/2	0.888	0.59	1.76	2.10	1.092	1.100
F	3/4	3/4	1/2	1.027	0.65	1.96	2.31	1.292	1.300
G	7/8	7/8	1/2	1.175	0.69	2.16	2.55	1.382	1.390
H	1	1	1/2	1.291	0.75	2.54	2.91	1.658	1.670

Brown Brothers Engineering Ltd

AGS 1214 BANJO BOLT with CONE HEAD CONNECTION

Material : LIGHT ALLOY
(ANODISED)

Working Pressure :
3000 lb./sq. in. for sizes up to 1/2" B.S.P.

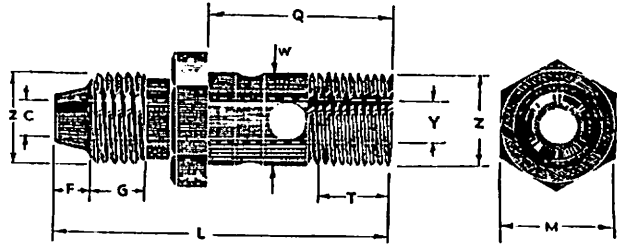

ITEM	O/D OF PIPE	1/2 B.S.P. THREAD	Y DIA. DRILL	W	T Min. Full Thd.	Q	M		L	G	F	C BORE
							MIN.	MAX.				
A	IN. 1/8	IN. 1/8	IN. 3/32	IN. 0.375	IN. 0.43	IN. 1.01	IN. 0.595	IN. 0.600	IN. 1.98	IN. 0.36	IN. 0.22	IN. 3/32
B	1/4	1/4	3/32	0.507	0.45	1.11	0.705	0.710	2.22	0.39	0.28	3/32
BB	5/16	19 T.P.I. Whit. form 0.60° O/D	3/32	0.589	0.45	1.26	0.815	0.820	2.41	0.40	0.32	1/8
C	3/8	3/8	1/16	0.645	0.49	1.36	0.915	0.920	2.54	0.42	0.32	1/4
CC	1/2	14 T.P.I. Whit. form 0.75° O/D	3/32	0.736	0.52	1.51	1.002	1.010	2.83	0.47	0.32	5/16
D	5/8	1/2	1/16	0.811	0.59	1.66	1.002	1.010	2.99	0.48	0.32	3/8

AGS 1215 BANJO BOLT with UNION HEAD CONNECTION

Material : LIGHT ALLOY
(ANODISED)

Working Pressures :
3000 lb./sq. in. for sizes up to 1/2" B.S.P.
500 lb./sq. in. for sizes 3/8" to 1" B.S.P.

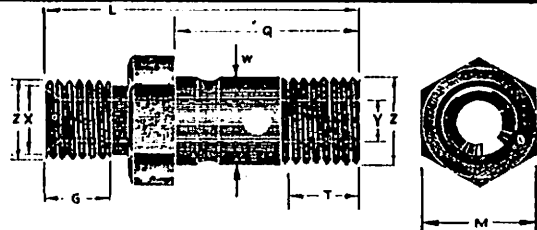

ITEM	O/D OF PIPE	1/2 B.S.P. THREAD	Y DIA. DRILL	X	W	T Min. Full Thd.	Q	M		L	G
								MIN.	MAX.		
A	IN. 1/8	IN. 1/8	IN. 3/32	IN. 0.295	IN. 0.375	IN. 0.43	IN. 1.01	IN. 0.595	IN. 0.600	IN. 1.75	IN. 0.35
B	1/4	1/4	3/32	0.410	0.507	0.45	1.11	0.705	0.710	1.90	0.35
BB	5/16	19 T.P.I. Whit. Form 0.60° O/D	3/32	0.480	0.589	0.45	1.26	0.815	0.820	2.09	0.40
C	3/8	3/8	1/16	0.550	0.645	0.49	1.36	0.915	0.920	2.19	0.40
CC	1/2	14 T.P.I. Whit. Form 0.75° O/D	3/32	0.600	0.736	0.52	1.51	1.002	1.010	2.53	0.45
D	5/8	1/2	1/16	0.690	0.811	0.59	1.66	1.002	1.010	2.71	0.53
E	3/4	3/4	1/16	0.760	0.888	0.59	1.76	1.092	1.100	2.85	0.55
F	7/8	7/8	1/16	0.900	1.027	0.65	1.96	1.292	1.360	3.05	0.55
G	1	1	1/16	1.040	1.175	0.69	2.16	1.382	1.390	3.40	0.65
H	1	1	1/16	1.130	1.291	0.75	2.54	1.658	1.670	3.89	0.70

Brown Brothers Engineering Ltd

AGS 1216 & 1217 (MILD STEEL) (BRASS) (CADIUM) (CADIUM)

UNION NUTS

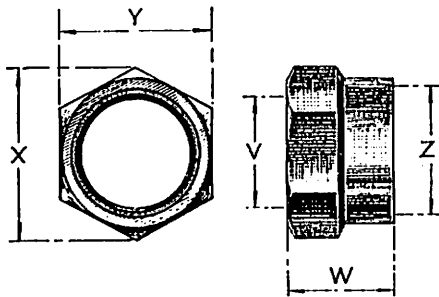

ITEM	Z	Y		X	W	V
	B.S.P. Thread	Max.	Min.	Approx.		
A	IN. 1/2	IN. 0.525	IN. 0.520	IN. 0.610	IN. 0.45	IN. 0.270
B	1/2	0.710	0.705	0.820	0.51	0.370
BB	0.60 O/D x 19 T.P.I.	0.820	0.815	0.950	0.57	0.440
C	1/2	0.820	0.815	0.950	0.60	0.500
CC	0.75 O/D x 14 T.P.I.	0.920	0.915	1.060	0.65	0.540
D	1/2	1.010	1.002	1.170	0.70	0.620
E	1/2	1.100	1.092	1.270	0.78	0.740
F	1/2	1.200	1.192	1.390	0.82	0.870
G	1/2	1.390	1.382	1.610	0.93	1.000
H	1	1.480	1.468	1.710	1.01	1.110
J	1 1/2	1.860	1.845	2.150	1.02	1.400
K	1 1/2	2.220	2.200	2.560	1.13	1.665
L	1 1/2	2.410	2.390	2.780	1.15	1.900
M	2	2.700	2.735	3.190	1.25	2.130

AGS 1218

PIPE COUPLING

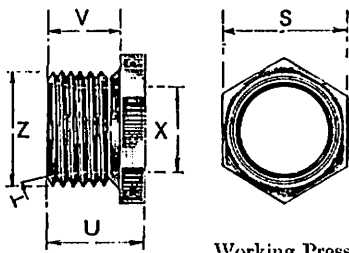

STANDARD INNER SLEEVE

Replacing AGS 712 & 905

Material : ALUMINIUM ALLOY

(ANODISED)

Working Pressure: 3000 lb./sq. in. up to 1/2" B.S.P.F., 500 lb./sq. in. 3/8"-3/4" B.S.P.F.

ITEM	EXT. DIA. OF PIPE	Z	X	V	U	T	S	
		B.S.P. Thread	Dia. Drill				Min.	Max.
A	IN. 1/2	IN. 1/2	IN. 1/2	IN. 0.50	IN. 0.70	13 1/2°	IN. 0.440	IN. 0.445
B	1/2	1/2	1/2	0.55	0.75	13 1/2°	0.520	0.525
BB	1/2	19 T.P.I. 0.60 O/D	1/2	0.60	0.80	13 1/2°	0.595	0.600
C	1/2	1/2	1/2	0.60	0.80	13 1/2°	0.705	0.710
CC	1/2	14 T.P.I. 0.75 O/D	1/2	0.70	0.95	13 1/2°	0.815	0.820
D	1/2	1/2	1/2	0.70	0.95	13 1/2°	0.915	0.920
E	1/2	1/2	1/2	0.70	0.95	14°	1.002	1.010
F	1/2	1/2	1/2	0.75	1.00	14°	1.092	1.100
G	1/2	1/2	1/2	0.75	1.00	14°	1.292	1.300

Brown Brothers Engineering Ltd.

AGS 1220

BANJO BOLT

For use with Bleeder Screw, see page 122

AGS 1229

PLUG, TRANSPORTATION

For Brass Protection Plug, see AGS 595

Material : BRASS (SELF-FINISH)

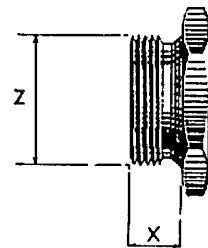

ITEM	A	B	BB	C	CC	D	E	F	G	H	J	K	M	P
	IN.	IN.	IN.	IN.	IN.	IN.	IN.	IN.	IN.	IN.	IN.	IN.		
Z B.S. Pipe	$\frac{1}{2}$	$\frac{1}{2}$	19 T.P.I. -60%	$\frac{3}{8}$	14 T.P.I. -75%	$\frac{1}{2}$	$\frac{5}{8}$	$\frac{3}{4}$	$\frac{7}{8}$	1	1 $\frac{1}{4}$	1 $\frac{1}{2}$		
X	-30	-32	-33	-34	-37	-41	-42	-43	-46	-53	-55	-59		
Jointing Washer AGS 164. Item	E	F	R	A	S	M	J	II	N	P	Q	K		

AGS 1230

RE-USABLE END FITTINGS

Material : LIGHT ALLOY (ANODISED)

Details and Prices on Application.

PARTS REQUIRED FOR ONE COMPLETE END FITTING		
ITEM No.	AGS No.	DESCRIPTION
1	1231	Union Nut
2	1232	Tailpiece
3	1233	Ferrule

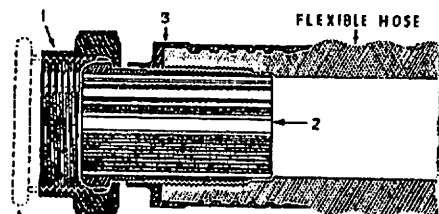

PROTECTION PLUG AGS 595

ITEM	A	B	C	D	E	F	G	H	J	K	L	M
1/Dis. of Hose	IN. $\frac{1}{2}$	IN. $\frac{1}{2}$	IN. $\frac{3}{8}$	IN. $\frac{1}{2}$	IN. $\frac{5}{8}$	IN. $\frac{3}{4}$	IN. $\frac{7}{8}$	IN. 1	IN. 1 $\frac{1}{4}$	IN. 1 $\frac{1}{2}$	IN. 1 $\frac{3}{4}$	IN. 2

Brown Brothers Engineering Ltd

AGS 1234 90° RE-USABLE END FITTINGS

For Non-Fire Resistant Hose to Spec. No D.T.D. (R.D.I.) 3951.

Material: ALUM. ALLOY

Details on Application

AGS 1235 45° RE-USABLE END FITTINGS

For Non-Fire Resistant Hose to Spec. No. D.T.D. (R.D.I.) 3951

Material: ALUM. ALLOY

Details on Application

AGS 1236 CONE CAPS

Material : STEEL (CADMIUM)

Working Pressures : 3000 lb./sq. in. for sizes up to ½" B.S.P.
 500 lb./sq. in. for sizes up to 1" B.S.P.
 200 lb./sq. in. for sizes up to 1½" B.S.P.

(Replacing AGS 1159)

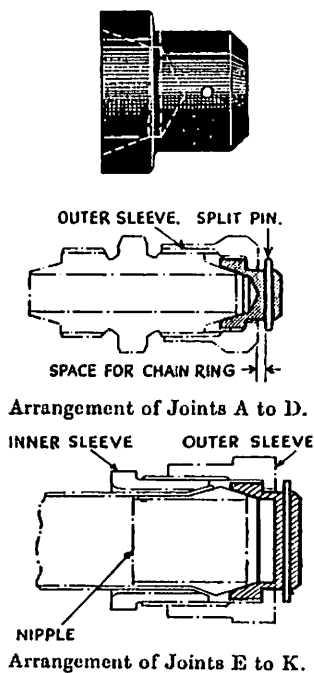

ITEM	B.S.P. THREAD	ITEM REQUIRED TO COMPLETE JOINT			
		OUTER SLEEVE	SPLIT PIN	INNER SLEEVE	NIPPLE
A	1"	AGS 904-A.	SP90-C3		
B	1"	AGS 2111	SP90-C5		
BB	19 T.P.I. 0.60%	AGS 904-BB	SP90-C5		
C	1"	AGS 904-C	SP90-C5		
CC	14 T.P.I. 0.75%	AGS 904-CC	SP90-C6		
D	1"	AGS 904-D	SP90-C6		
E	1"	AGS 904-E	SP90-C7	AGS 1218-E	AGS 1170-E
F	1"	AGS 904-F	SP90-C8	AGS 1218-F	AGS 1170-F
G	1"	AGS 904-G	SP90-C9	AGS 1218-G	AGS 1170-G
H	1"	AGS 904-H	SP90-C11	AGS 905-H	AGS 1170-H
J	1½"	AGS 904-J	SP90-C13	AGS 905-J	AGS 1170-J
K	1½"	AGS 904-K	SP90-C15	AGS 905-K	AGS 1170-K

Brown Brothers Engineering Ltd

AGS 1237 90° RE-USABLE END FITTING

For 1/4" I/D Non-Fire Resistant Hose to Spec. No. D.T.D. (R.D.I.) 3951

Material: STAINLESS STEEL. Details on Application

AGS 1238 45° RE-USABLE END FITTING

For 1/4" I/D Non-Fire Resistant Hose to Spec. No. D.T.D. (R.D.I.) 3951

Material: STAINLESS STEEL. Details on Application

AGS 1512 OUTER SLEEVES

For 9.5 mm. H.T. Metal Braided Cable

Material : BRASS (ELECTRO-TINNED)



AGS 1513 INNER SLEEVES

For H.T. Metal Braided Cable

Material: BRASS (ELECTRO-TINNED)

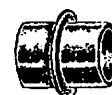

AGS 1516 TERMINAL LUGS

For 9 mm. Cable

Material: BRASS

Finish: ELECTRO-TINNED



AGS 1517 UNION NUT

For H.T. Cable

Material : BRASS (ELECTRO-TINNED)

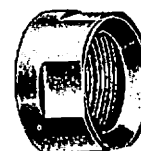

Brown Brothers Engineering Ltd

AGS 1519

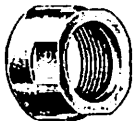

**UNION NUTS
For L.T. Cable**

Material : BRASS (ELECTRO-TINNED)

AGS 1520

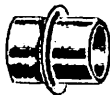

**INNER SLEEVES
For Unisheathmet 7 Cable**

Material : BRASS (ELECTRO-TINNED)

AGS 1521



**OUTER SLEEVES
For Unisheathmet 7 Cable**

Material : BRASS (ELECTRO-TINNED)

AGS 1523

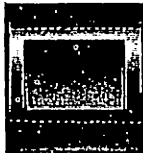

**IDENTIFICATION SLEEVES
For L.T. Cable**

**Material: SYNTHETIC RESIN COMPOUND
Engraving when required to order**

AGS 1524



**TERMINAL LUGS
For 7 mm. Ignition Cable**

Material : BRASS (ELECTRO-TINNED)

Brown Brothers Engineering Ltd

AGS 1529

BONDING STRIP SCREWS

**Material : MILD
STEEL
(CADMIUM)**

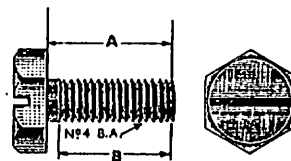

ITEM	A	B	C	D	E
A IN.	0.25	0.30	0.40	0.50	0.60
B IN.	0.20	0.25	0.35	0.45	0.55

AGS 1531 THIMBLES FOR CAMBRIC COVERED H.T. CABLES

**Material : BRASS
(ELECTRO-TINNED)**



AGS 1536

BONDING CLIPS

**Material : BRASS
(ELECTRO-TINNED)**

ITEM	A	B	C
A	IN. 0.28	IN. 0.37	IN. 0.05
B	0.37	0.43	0.05

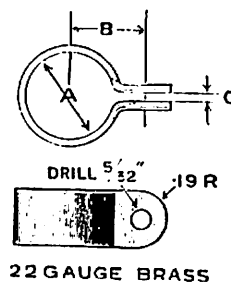

AGS 1538

TERMINAL LUGS FOR 5 mm. IGNITION CABLE

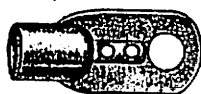

**Material : BRASS
(ELECTRO-TINNED)**

Brown Brothers Engineering Ltd

AGS 1541

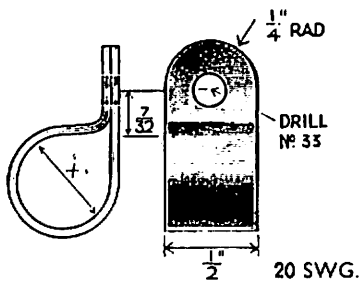

ELECTRIC CABLE CLEATS

Material : BRASS
(ELECTRO-TINNED)

ITEM	A	B	C	D	E	I
X	IN. 1/4	IN. 5/16	IN. 3/8	IN. 7/16	IN. 1/2	IN. 3/4

AGS 1542

ELECTRIC CABLE SADDLES

Material : ALUMINIUM (ANODISED)

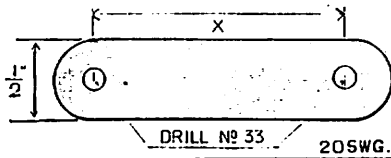

ITEM	A	B	C	D	E	F	G	I
X	IN. 1	IN. 1 1/4	IN. 1 1/2	IN. 1 3/4	IN. 2	IN. 2 1/4	IN. 2 1/2	IN. 3

AGS 1551

LOCKING PIN

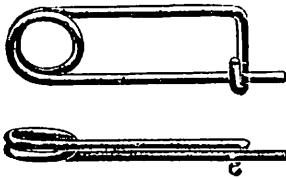

Material : SPRING
STEEL
(CADMIUM)

Pins to this pattern supplied
in any required size.

ITEM	To Suit NUTS
1	2 BA. 3/2" & 1/4" BSF.
2	3/8", 1/2", 3/4" BSF.
3	7/16", 1/2" BSF.
4	1/8", 1/4", 3/8" BSF.
5	1/2", 3/4" BSF.
6	1" BSF.

AGS 1562

SWITCH CLAMP

For 2 L.T. Cables

Material : ALUMINIUM ALLOY (SELF-FINISH)

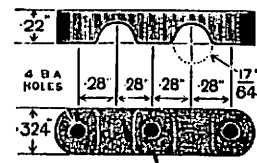

Brown Brothers Engineering Ltd

AGS 1593, 1594, 1595 & 1596 TERMINALS (CLAW TYPE)

(6 BA) (4 BA) (2 BA) (0 BA)

Material: BRASS
(ELECTRO-TINNED OR NICKEL PLATED)

PART NO.	TERMINAL SIZE	TO TAKE CABLE
1593A	6 BA	UNIFLEX 4
1594A	4 BA	UNIFLEX 4
1594B	4 BA	UNISHEATH 4
1595A	2 BA	UNISHEATH 4
1595B	2 BA	UNIPUG
1596A	0 BA	UNISHEATH 4
1596B	0 BA	UNIPUG

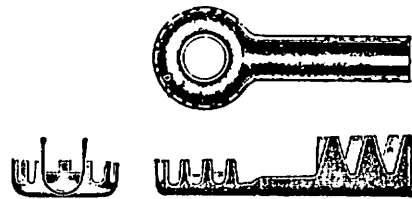

AGS 1599 BONDING WIRE SOCKET

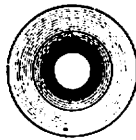
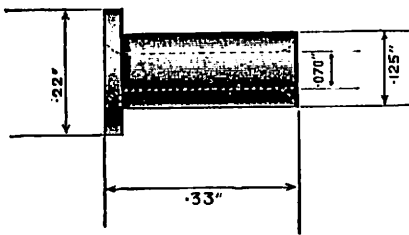

Material: BRASS
(ELECTRO-TINNED)

AGS 1600 TERMINALS (CABLE END)

Material: BRASS SHEET, 22 S.W.G.
(ELECTRO-TINNED)

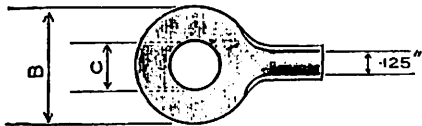

ITEM	SIZE	B	C
		IN.	IN.
A	4 BA	0.35	0.15
B	2 BA	0.45	0.19
C	1/4"	0.6	0.26
D	5/16"	0.6	0.32

AGS 1606 CABLE SLEEVES

Material: BRASS
(ELECTRO-TINNED)

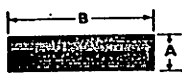

ITEM	A	B	GAUGE SWG	ITEM	A	B	GAUGE SWG
	IN.	IN.			IN.	IN.	
1	0.083	0.25	28	5	0.125	0.625	28
2	0.110	0.25	24	6	0.125	0.75	28
3	0.110	0.50	24	7	0.135	0.50	28
4	0.125	0.50	28				

AGS 1612 BONDING LEADS

Material: FLEXIBLE COPPER CORD (Construction 16 x 4 x .0048") and AGS 1599.
Length Overall 5" or as required

Brown Brothers Engineering Ltd

AGS 1615

TERMINAL TAGS

(P.O. Type Nos. 29, 30, 31 & 32)

Material : BRASS SHEET

(MATT NICKELLED)

OR NICKEL SILVER SHEET

(BRIGHT)

Tools for Crimping these Tags, P.O. Tool Inst. No. 213 (Mark 231)

TAG No.	To Suit TERMINAL	TYPE
29	8 B.A.	RING
30	6 B.A.	RING
31	4 B.A.	SPADE
32	6 B.A.	SPADE

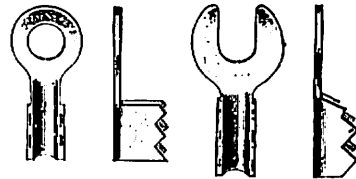

AGS 1616 SLEEVE (Inner)

(Short for 9.5 m/m. metal braided cable)

Material: BRASS (ELECTRO-TINNED)



AGS 1617

ELECTRIC CABLE CLEATS

Material : LIGHT ALLOY

(SELF)

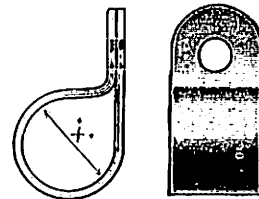

ITEM	1	2	3	4	5	6	7	8	9	10	11	12	13
×	1/8"	3/32"	1/16"	3/32"	1/4"	5/16"	3/8"	7/16"	1/2"	5/8"	3/4"	7/8"	1"

Brown Brothers Engineering Ltd

AGS 1624

(7 mm. Cable)

TERMINALS

Complete assembly comprising :

Spring Loaded type for Magneto
H.T. Cables

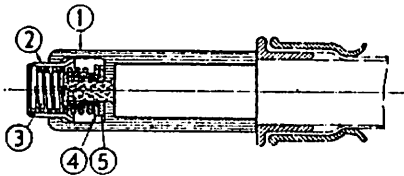

DESCRIPTION	7 MM. CABLE
Cable Sleeve	AGS 1624/1
Plunger	AGS 1624/2
Spring	AGS 1624/3
Nipple (Outer)	AGS 1624/4
Nipple (Inner)	AGS 1624/5

AGS 1629

SLEEVE (Inner)

Medium, for 8.5 mm. Metal Braided Cable

Material : BRASS

(ELECTRO-TINNED)

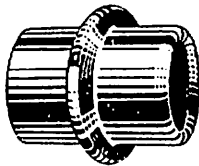

AGS 1630

SLEEVE (Inner) Short

(Short for 8.5 mm. metal braided cable)

Material: BRASS (ELECTRO-TINNED)



AGS 1634

UNION NUT

For H.T. Cables

Material : BRASS

(ELECTRO-TINNED)

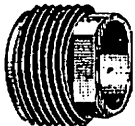

AGS 1635

UNION NUT

For L.T. Cables

Material : BRASS

(ELECTRO-TINNED)

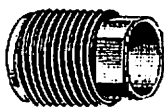

AGS 1636

SLEEVE (Inner)

For Unisheathmet 7 Cable

Material : BRASS (ELECTRO-TINNED)



Brown Brothers Engineering Ltd

AGS 1638

SLEEVE (Outer)

For Unisheathmet 7 Cable

Material : BRASS
(ELECTRO-TINNED)



AGS 1639

SLEEVE (Inner)

For Unisheathmet 7 Cable

Material : BRASS
(ELECTRO-TINNED)



AGS 1651

SLEEVE (Type I) CIRCULAR

ITEM	FOR CABLES
1	Unicel 4 and Unicel 7
2	Unisheath 4 and 7 and Unicel 19
3	Tricel 4 and Unisheath 19
4	Quadracel 4, Quincel 4, Tricel 7, Trisheathsmall 4 and Unicel 37
5	Quincel 7, Septocel 4, Quintosheathsmall 4
6	Septocel 7, Tricel 19, Septosheathsmall 4, and Trigen T.R.S. No. 1
7	Dusheath 7 and Quadragen T.R.S. No. 1
8	Dusheath 19 and Unicel 64
9	Quadragen T.R.S. No. 2, Tricel 37 and Trigen No. 2
10	Quadragen T.R.S. No. 3 and Trigenvin No. 2
11	Quadragen T.R.S. No. 2, Trigen T.R.S. No. 2 and Trigenvin No. 1 (Special)
12	Univin 83, Twelvecin 7, Unistartvin No. 2, Trigenvin No. 1 and Eighteencin 4
13	Univin 138 and Twenfivecorevin



Material :
BRASS, 22 S.W.G.
(ELECTRO-TINNED)

AGS 1652

SLEEVE (Type I) OVAL

ITEM	FOR CABLE
1	Ducel 4
2	Ducel 7 and Dusheathsmall 4
3	Ducel 19
4	Ducel 37
5	Duvin 64
6	—
7	—

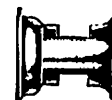

Material:
BRASS, 22 S.W.G.
(ELECTRO-TINNED)

Brown Brothers Engineering Ltd

AGS 1653 & 1654 SLEEVE (Type 2) CIRCULAR

(Inner) (Outer)

Material : BRASS, 22 S.W.G. (ELECTRO-TINNED)



AGS 1653
(Inner)

The cables shown are for both AGS 1653 & 1654

AGS 1654
(Outer)



ITEM	FOR CABLE	ITEM	FOR CABLE
1	Unisheathmet 7 and Trimet 4	13	Eightecorevinmet No. 2
2	Trimet 7, Quadramet 4 and Quintomet 4	14	Sextocorevinmet No. 1
3	Sextomet 4, Septomet 4, Trimet 19 and Trigenmet 1	15	Twelvecorevinmet No. 2
4	Dusheathmet 4, Sextomet 7, Septomet 7 and Quadragenmet 1	16	Ducorevinmet No. 1
5	Dusheathmet 7	17	Sextocorevinmet No. 3
6	Dusheathmet 19 and Trigenmet 2	18	Sextocorevinmet No. 2
7	Quadragenmet 2	19	Unlmet 7
8	Dusheathmet 37	20	Unlmet 4
9	Quadragenmet 3 and Trigenmet 3	21	Ducorevinmet No. 3
10	Trigenmet 2 (Special)	22	Eightecorevinmet No. 1
11	Quadragenmet 2 (Special)	23	Eightecorevinmet No. 2
		24	Twenfivecorevinmet

AGS 1655 & 1656 SLEEVE (Type 2) OVAL

(Inner) (Outer)

Material : BRASS, 22 S.W.G. (ELECTRO-TINNED)

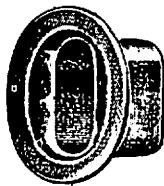

AGS 1655
(Inner)

ITEM	FOR CABLE
1	Dumet 4 & 7
2	Dumet 19
3	Dumet 37
4	—
5	—
6	—
7	—

AGS 1656
(Outer)

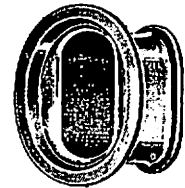

AGS 1657 COLLET

Material : STEEL (CADMIUM)

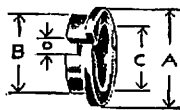

ITEM	A	B	C	D	ITEM	A	B	C	D
0	IN. 0.56	IN. 0.63	IN. 0.41	IN. 0.128	5	IN. 1.16	IN. 1.05	IN. 0.87	IN. 0.62
1	0.68	0.58	0.54	0.37	6	1.26	1.18	1.00	0.68
2	0.80	0.71	0.59	0.37	7	1.33	1.25	1.12	0.75
3	0.90	0.80	0.68	0.41	8	0.56	0.53	0.41	0.28
4	1.02	0.93	0.78	0.56					

Brown Brothers Engineering Ltd

AGS 1658

GLAND NUT

Material : STEEL
(CADMIUM)

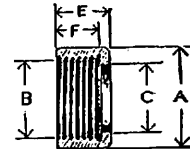

ITEM	A		B		C	E	F	REF. NO.	ITEM	A		B		C	E	F	REF. NO.
	IN.	DIAM.	T.P.I.	IN.	IN.	IN.	IN.			IN.	IN.	T.P.I.	IN.	IN.	IN.	IN.	
0	0.70	0.625	26	0.50	0.31	0.26	5K/87	5A	1.35	1.25	16	0.90	0.50	0.45	5K/97		
1	0.70	0.625	26	0.50	0.37	0.32	5K/88	6	1.35	1.25	16	1.03	0.50	0.45	5K/98		
1A	0.85	0.75	26	0.50	0.37	0.32	5K/89	6A	1.46	1.375	16	1.03	0.50	0.45	5K/99		
2	0.85	0.75	26	0.625	0.37	0.32	5K/90	7	1.46	1.375	16	1.18	0.50	0.45	5K/100		
2A	0.95	0.875	26	0.625	0.37	0.32	5K/91	7A	1.55	1.437	16	1.18	0.50	0.45	5K/101		
3	0.95	0.875	26	0.70	0.37	0.32	5K/92	8	0.95	1 1/8	20	0.625	0.50	0.45	5K/145		
3A	1.10	1.00	16	0.70	0.37	0.32	5K/93	9	1.00	0.90	20	0.625	0.50	0.45	5K/146		
4	1.10	1.00	16	0.80	0.37	0.32	5K/94	10	1.05	1 1/8	20	0.80	0.50	0.45	5K/147		
4A	1.20	1.125	16	0.80	0.50	0.45	5K/95	11	0.75	0.687	26	0.57	0.37	0.32	5K/2364		
5	1.20	1.125	16	0.90	0.50	0.45	5K/96										

AGS 1661

WATER PIPE BONDING CLIPS

Replacing AGS 1510 and AGS 1613

Material:

Clip—BRASS (ELECTRO-TINNED)

Bolt—STEEL (CADMIUM)

Nut—STEEL (CADMIUM)

ITEM	X		Y	Z	W	ITEM	X		Y	Z	W
	IN.	IN.	IN.	B.S.			IN.	IN.	IN.	B.S.	
A	0.5	0.2	0.31	A31/B324	H	1.5	0.45	0.38	A31/B32		
B	0.63	0.2	0.31	A31/B24	J	1.75	0.45	0.38	A31/B32		
C	0.75	0.2	0.31	A31/B24	K	2.0	0.45	0.38	A31/B32		
D	0.88	0.2	0.31	A31/B24	L	2.25	0.45	0.38	A31/B32		
E	1.0	0.2	0.31	A31/B24	M	2.50	0.45	0.38	A31/B32		
F	1.13	0.3	0.38	A31/B28	N	2.75	0.45	0.38	A31/B32		
G	1.25	0.45	0.38	A31/B32							

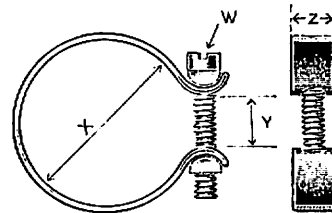

Brown Brothers Engineering Ltd

AGS 1666

WIRING CLEATS



Material : BRASS (ELECTRO-TINNED)



ITEM	2	3	4	5	6	7	8
DIA. 'A'	IN. 0.875	IN. 1.375	IN. 1.75	IN. 2.0	IN. 2.5	IN. 2.75	IN. 3.125

AGS 1671

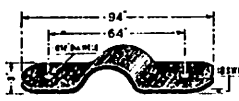
WIRING CLEATS

ITEM A	ITEM B	Material : ALUMINIUM (SELF-FINISH)
		

AGS 1672

WIRING CLEATS

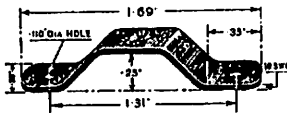
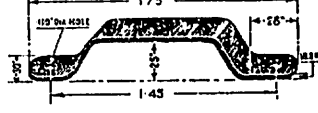
ITEM A	ITEM B	Material : ALUMINIUM (SELF-FINISH)
		

AGS 1678

CABLE END

Fork Type, Channel End. Material : COPPER (ELECTRO-TINNED)

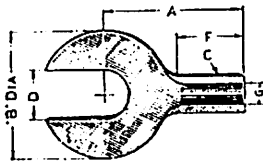

ITEM	REF. No.	SIZE	A	B	C	D	F	G
A	5K/1606	0 BA	IN. 0.73	IN. 0.66	SWG 21	IN. 0.26	IN. 0.35	IN. 0.16
B	5K/1604	2 BA	0.65	0.50	21	0.20	0.35	0.10
C	5K/1603	4 BA	0.46	0.31	22	0.16	0.25	0.08
D	5K1,602	6 BA	0.375	0.26	23	0.125	0.20	0.062

AGS 1681

CABLE END

Eye Type, Channel End. Material : COPPER (ELECTRO-TINNED)

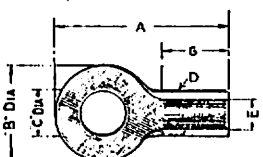

ITEM	REF. No.	SIZE	A	B	C	D	E	G
A	5K/298	0 BA	IN. 0.90	IN. 0.60	IN. 0.26	SWG 23	IN. 0.16	IN. 0.35
D	5K/301	6 BA	0.62	0.30	0.13	26	0.10	0.25

Brown Brothers Engineering Ltd

AGS 1686 & 1687

SLEEVE (Type 4)

Material : BRASS

(ELECTRO-TINNED)



AGS 1686 INNER



AGS 1687 OUTER

ITEM	FOR CABLE	REF. No.	ITEM	FOR CABLE	REF. No.
1	Dumet 4	5K/73	1	Dumet 4	5K/76
2	Trimet 4 & Quadramet 4	5K/74	2	Trimet 4 & Quadramet 4	5K/77
3	Quintomet 4	5K/75	3	Quintomet 4	5K/78
4	Duradio 28	5K/197	4	Duradio 28	5K/198

AGS 1688

**CABLE SLEEVE
(Type 1) CIRCULAR**

ITEM	FOR CABLE	REF. No.
1	Duvel 7, Tricel 7 & Trisheathsmall 7	5K/33
2	Quincoel 7 & Quintosheathsmall 4	5K/34
3	Septocel 7 & Septosheathsmall 4	5K/35

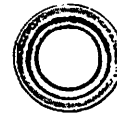

**Material : BRASS, 22 S.W.G.
(ELECTRO-TINNED)**

AGS 1689

**SLEEVE FOR DUSHEATHSMALL 4 CABLE
(Type 1) OVAL**

**Material : BRASS, 22 S.W.G.
(ELECTRO-TINNED)**

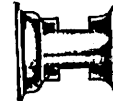

AGS 1690

WIRING CLEAT

**Material : ALUMINIUM
(SELF-FINISH)**



Brown Brothers Engineering Ltd

AGS 1691 CABLE END, CROWN EYE TYPE

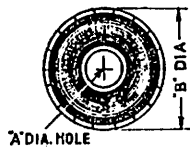

Material: BRASS
(ELECTRO-TINNED)

ITEM	A	B	C	D	E	REF. No.
A	IN. 0.125	IN. 0.343	IN. 0.156	IN. 0.300	IN. 0.170	5K/010
AA	0.156	0.343	0.156	0.300	0.187	5K/184
B	0.156	0.406	0.187	0.340	0.202	5K/011
BB	0.187	0.400	0.187	0.340	0.233	5K/14
C	0.250	0.025	0.187	0.650	0.207	5K/012
D	0.375	0.812	0.281	0.742	0.430	5K/013
E	0.156	0.500	0.250	0.465	0.202	5K/186
F	0.312	0.812	0.281	0.742	0.367	5K/2505

AGS 1703—1706

TERMINAL LUGS

Material: BRASS (ELECTRO-TINNED)

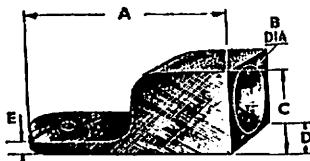

AGS No.	A	B	C	D	E
1703	IN. 1.7	IN. 0.45	IN. 0.6	IN. 0.6	IN. 0.125
1704	1.7	0.34	0.5	0.5	0.08
1705	1.7	0.218	0.36	0.36	0.08
1706	2.0	0.55	0.7	0.7	0.125

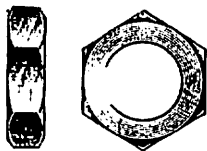

AGS 1710 L.T. UNION LOCKNUT

$\frac{1}{2}$ " \times 26 T.P.I. Whit. Form.

Material: BRASS

(ELECTRO-TINNED)

Brown Brothers Engineering Ltd

AGS 1713

L.T. CABLE END

Material : BRASS
(ELECTRO-TINNED)



AGS 1714

L.T. INSULATING CABLE SLEEVE

Material : 'TUFNOL'



AGS 1715

No. 7 TERMINAL LUG

Material : BRASS
(ELECTRO-TINNED)

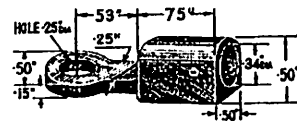

AGS 1722

CABLE SLEEVE (TRIGENMET)

Material : BRASS (ELECTRO-TINNED)

	ITEM	X	Y	Z
		IN.	IN.	IN.
A	INNER	0.890	0.946	1.08
B	OUTER	0.970	1.026	1.08

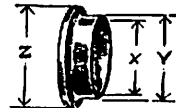

AGS 1723 CABLE SLEEVE (Inner) (TRIGENMET No. 2)

Material : BRASS
(ELECTRO-TINNED)

	X	Y	Z
	IN.	IN.	IN.
	0.565	0.616	1.08

AGS 1724 CABLE SLEEVE (Outer) (TRIGENMET No. 2)

Material : BRASS (ELECTRO-TINNED)



Brown Brothers Engineering Ltd

AGS 1725

BLANKING DISCS

For use under Gland Nuts where Cable Sleeves are not fitted



Material : MILD STEEL
(CADMIUM)

ITEM	A
1	IN. 0.565
2	0.685
3	0.875

AGS 1726

SLEEVE (Type 3) CIRCULAR



Material :
BRASS
(ELECTRO-TINNED)

ITEM	DESCRIPTION	FOR CABLE
1	INNER SLEEVE	QUADRAGENMET 2
2	OUTER SLEEVE	QUADRAGENMET 2
3	INNER SLEEVE	QUADRAGENMET 1
4	OUTER SLEEVE	QUADRAGENMET 1
5	INNER SLEEVE	UNIMET 7
6	OUTER SLEEVE	UNIMET 7

AGS 1727

SLEEVE (Type 3) CIRCULAR (Inner)



Material : BRASS
(ELECTRO-TINNED)

ITEM	FOR CABLE
1	QUADRAGENMET 2
2	UNIMET 37

AGS 1729

SLEEVE (Type 3) CIRCULAR (Outer)

For L.T. Metal Braided Cable

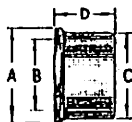

Material : BRASS
(ELECTRO-TINNED)

A	B	C	D
IN. 0.58	IN. 0.428	IN. 0.535	IN. 0.33

AGS 1731

SLEEVE, CIRCULAR (Outer)

For L.T. Metal Braided Cable

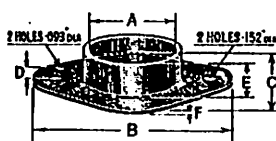

Material : BRASS
(ELECTRO-TINNED)

A	B	C	D	E	F
IN. 0.97	IN. 1.86	IN. 1.25	IN. 0.19	IN. 0.30	IN. SWG. 22

Brown Brothers Engineering Ltd

AGS 1732 SLEEVE (Type 8) CIRCULAR (Outer and Inner)

For L.T. Metal Braided Cable

Material: BRASS (ELECTRO-TINNED)

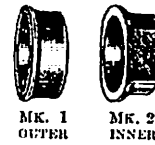

AGS 1733 SLEEVE (Type 1) CIRCULAR

For L.T. Cable

Material: BRASS
(ELECTRO-TINNED)

ITEM	A	B	C	D	E	F	G
1	IN. 0.53	IN. 0.68	IN. 0.20	IN. 0.62	IN. 0.20	IN. 0.20	IN. 0.55
2	0.43	0.56	0.20	0.49	0.20	0.20	0.55
3	0.65	1.15	0.30	0.84	0.25	0.25	0.80

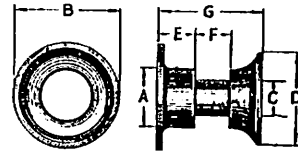

AGS 1734 SLEEVE (Type 4) CIRCULAR (Inner)

For L.T. Metal Braided Cable

Material: BRASS
(ELECTRO-TINNED)

ITEM	A	B	C	D
1	IN. 0.61	IN. 0.677	IN. 1.10	IN. 0.49
2	0.61	0.677	0.96	0.49
3	0.368	0.420	0.61	0.23
4	0.404	0.47	0.61	0.23

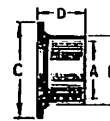

AGS 1735 SLEEVE (Type 9) CIRCULAR (Outer)

For L.T. Metal Braided Cable

Material: BRASS
(ELECTRO-TINNED)

ITEM	A	B	C	D
1	IN. 0.445	IN. 0.50	IN. 0.61	IN. 0.35
2	0.495	0.55	0.61	0.35
3	0.702	0.84	1.10	0.80
4	0.702	0.84	0.96	0.55

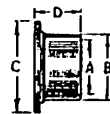

Brown Brothers Engineering Ltd

AGS 1737 TERMINAL LUG (Nos. 10 & 11)

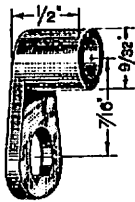

Material : BRASS (ELECTRO-TINNED)

ITEM	LUG No.	DIA. CABLE HOLE
1	10	IN. 0.1875

AGS 1738 TERMINAL LUG (Nos. 12 & 13)

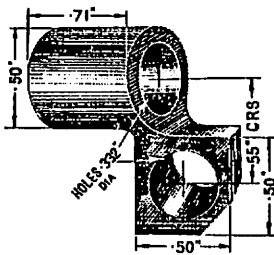

Material : BRASS (ELECTRO-TINNED)

ITEM	LUG No.	
1	12	Right-hand
2	13	Left-hand

AGS 1741 TERMINAL LUG (Nos. 16 & 31)

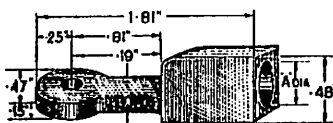

Material : BRASS (ELECTRO-TINNED)

ITEM	LUG No.	" A " DIMENSION
A	16	IN. 0.344
B	31	0.201

AGS 1744 TERMINAL LUG (No. 17)

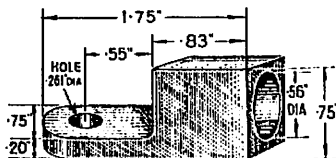

Material: BRASS (ELECTRO-TINNED)

AGS 1745 TERMINAL EYELET



Material : BRASS (ELECTRO-TINNED)

Brown Brothers Engineering Ltd

AGS 1746 TERMINAL LUG (No. 18)

Material : BRASS (ELECTRO-TINNED)

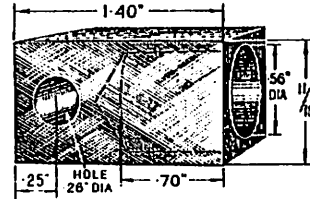

AGS 1747 TERMINAL LUG (No. 19, 23, 24 & 27)

Material : BRASS (ELECTRO-TINNED)

ITEM	LUG No.	A	B	C	D	E	F
A	19	IN. 0.42	IN. 0.261	IN. 1.00	IN. 0.45	IN. 0.25	1/2" sq.
B	23	0.34	0.201	0.80	0.32	0.25	1/2" sq.
C	24	0.201	0.201	0.75	0.30	0.25	1/2" sq.
D	27	0.201	0.152	0.69	0.30	0.188	5/16" sq.

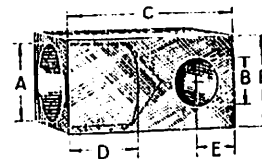

AGS 1748 TERMINAL LUG (No. 22)

(D.C. Output on "UK.X" (GENERATOR))

Material : BRASS (ELECTRO-TINNED)

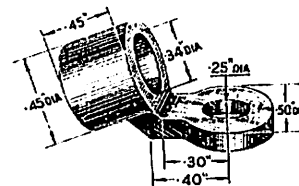

AGS 1749 TERMINAL LUG (Nos. 28 & 29)

Material : COPPER TUBE (ELECTRO-TINNED)

ITEM	LUG No.	"A" DIA.
A	28	IN. 0.390
B	29	0.328

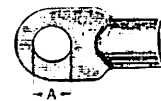

Brown Brothers Engineering Ltd

AGS 1756 FLANGED GLAND (Round) FOR CABLES

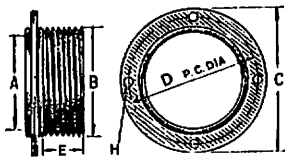

Material: STEEL
(CADMIUM)

ITEM	A	B		C	D	E	H	FITS COUPLING NUT
		Dia. IN.	T.P.I.					
1	0.510	0.625	26	1.000	0.812	0.32	$\frac{1}{4}$	AGS 1658-0/1
2	0.600	0.750	26	1.150	0.937	0.32	$\frac{1}{8}$	AGS 1658-1A/2
3	0.725	0.875	26	1.310	1.090	0.32	$\frac{1}{8}$	AGS 1658-2A/3
4	0.820	1.000	16	1.500	1.250	0.32	$\frac{3}{8}$	AGS 1658-3A/4
5	0.950	1.125	16	1.500	1.312	0.60	$\frac{3}{8}$	AGS 1658-4A/5
6	1.070	1.250	16	1.750	1.500	0.50	$\frac{3}{8}$	AGS 1658-5A/6
7	1.200	1.375	16	1.875	1.625	0.50	$\frac{3}{8}$	AGS 1658-6A/7
8	1.270	1.437	16	1.950	1.687	0.50	$\frac{3}{8}$	AGS 1658-7A
9	0.950	1.125	16	1.620	1.370	0.50	$\frac{3}{8}$	AGS 1658-4A/5
10	1.460	1.625	20	2.130	1.875	0.50	$\frac{3}{4}$	Stores Ref. No. 5X/257
11	1.460	1.625	20	2.240	1.950	0.50	$\frac{3}{4}$	Stores Ref. No. 5X/257

AGS 1757 FLANGED GLAND (Oval) FOR CABLES

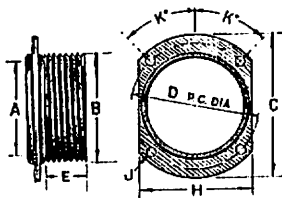

Material:
STEEL
(CADMIUM)

ITEM	A	B		C	D	E	H	J	K	FITS COUPLING NUT
		Dia. IN.	T.P.I.							
1	0.510	0.625	26	1.000	0.812	0.32	0.650	$\frac{1}{4}$	30°	AGS 1658-0/1
2	0.600	0.750	26	1.150	0.937	0.32	0.780	$\frac{1}{8}$	30°	AGS 1658-1A/2
3	0.725	0.875	26	1.310	1.090	0.32	0.900	$\frac{1}{8}$	30°	AGS 1658-2A/3
4	0.820	1.000	16	1.500	1.250	0.32	1.100	$\frac{1}{2}$	45°	AGS 1658-3A/4
5	0.950	1.125	16	1.625	1.375	0.60	1.200	$\frac{1}{2}$	45°	AGS 1658-4A/5
6	1.070	1.250	16	1.750	1.500	0.50	1.280	$\frac{3}{8}$	45°	AGS 1658-5A/6
7	1.200	1.375	16	1.875	1.625	0.50	1.400	$\frac{3}{8}$	45°	AGS 1658-6A/7
8	1.270	1.437	16	1.950	1.687	0.50	1.470	$\frac{3}{8}$	45°	AGS 1658-7A
9	0.950	1.125	16	1.620	1.370	0.50	1.150	$\frac{1}{2}$	45°	AGS 1658-4A/5
10	1.200	1.375	16	1.875	1.625	0.50	1.430	$\frac{3}{8}$	45°	AGS 1658-6A/7

INSTRUMENT TERMINALS

Material: BRASS
(NICKEL PLATED)

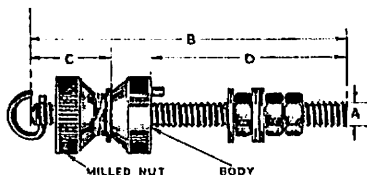

AGS 1759 (SINGLE)

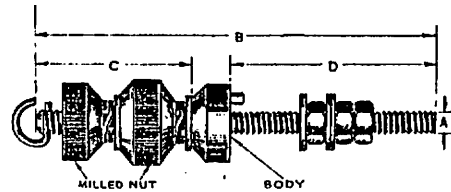

AGS 1760 (DOUBLE)

SIZE	DIMENSIONS			WASHER	SPRING-WASHER	NUTS U.S. SPEC. ALL	SIZE	DIMENSIONS		
	A	B	C					D	A	B
1" JISF	IN. 2.60	IN. 0.79	IN. 1.50	AGS No. 1582-A	AGS No. 1583-A	2B	1" JISF	IN. 3.28	IN. 1.47	IN. 1.50
2 BA	2.64	0.73	1.50	1582-B	1583-B	2B	2 BA	3.17	1.38	1.50
4 BA	2.15	0.64	1.25	1582-C	1583-C	4B	4 BA	2.70	1.19	1.25
6 BA	1.75	0.54	1.00	1582-D	1583-D	6B	6 BA	2.27	1.00	1.00
8 BA	1.35	0.47	0.75	1582-E	1583-E	8B	8 BA	1.74	0.88	0.75
10 BA	1.00	0.39	0.50	1582-F	1583-F	10B	10 BA	1.35	0.72	0.50

Brown Brothers Engineering Ltd

AGS 1761

TERMINAL LUG No. 25

Material: BRASS

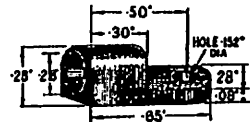

AGS 1762 CABLE SLEEVES, SINGLE (WEATHERPROOFING)

Material:
SYNTHETIC RUBBER

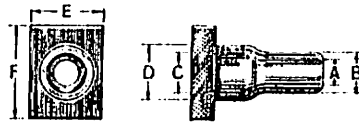

ITEM	A	B	C	D	E	F
A	IN. 0.140	IN. 0.210	IN. 0.185	IN. 0.255	IN. 0.380	IN. 0.480
	0.135	0.200	0.180	0.245	0.375	0.475

AGS 1766 CABLE LUG WEATHER-PROOFING SLEEVE

Material : SYNTHETIC RUBBER

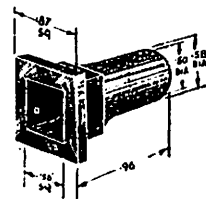

AGS 1767

CABLE END FITTING (For Magneto)

Material : BRASS (ELECTRO-TINNED)

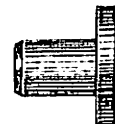

AGS 2001-2020

ODDIE NUTS AND ANCHORAGES

PLEASE REFER TO SPECIAL ODDIE SECTION

Pages 255-264

AGS 2030

INTERNAL CIRCLIPS

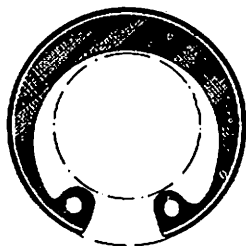

Material: STEEL
(PHOSPHATE AND OIL)

TABLE OF SIZES

ITEM	TO SUIT BORES OF DIAMETER	ITEM	TO SUIT BORES OF DIAMETER	ITEM	TO SUIT BORES OF DIAMETER	ITEM	TO SUIT BORES OF DIAMETER
1	1/2"	34	1 1/8", 1 1/4", 1 1/2" & 28 mm.	87	2 1/2" & 2 1/4"	118	3 1/2"
2	5/8", 1" & 1 1/8"	36	1 1/2"	88	2 3/4" & 2 3/8"	110	3 3/4", 90 mm. & 3 1/2"
3	1 1/8"	37	1 1/4" & 1 1/2"	89	2 3/4", 2 1/2" & 2 3/8"	111	3 1/2" & 3 1/4"
4	1 1/4"	19	1 1/2", 1 1/4", 30 mm. & 1 1/2"	91	58 mm., 2 1/2", 2 1/4" & 2 1/8"	112	95 mm. & 3 3/4"
7	1 1/2", 1 1/4" & 1 1/8"	39	1 1/2", 1 1/4", 1 1/8", 1 1/4", 32 mm.	93	2 1/2"	117	3 1/2"
9	1 3/4" & 1 1/2"	41	1 1/2" & 1 1/4"	94	2 1/2" & 62 mm.	60	3 1/2", 100 mm. & 3 1/4"
5	1 1/2", 1 1/4" & 1 1/8"	42	1 1/2" & 1 1/4"	95	2 1/2"	146	4"
6	6 mm.	43	1 1/2" & 1 1/4"	96	2 1/2"	61	4 1/4", 4 1/8" & 105 mm.
10	1 1/2" & 1 1/4"	23	1 1/2", 1 1/4" & 35 mm.	97	2 1/2", 2 1/4" & 2 1/8"	62	4 1/2" & 4 1/4"
16	1 1/2"	45	1 1/2", 1 1/4", 1 1/8" & 1 1/4"	132	2 1/2" & 2 1/4"	65	4 1/2", 110 mm. & 4 1/4"
11	1 1/2" & 1 1/4"	25	1 1/2", 37 mm. & 1 1/4"	101	2 1/2" & 2 1/4"	145	4 1/2"
13	1 1/2"	25	1 1/2", 38 mm. & 1 1/4"	102	2 1/2" & 70 mm.	66	4 1/2", 115 mm. & 4 1/4"
14	1 1/2" & 10 mm.	26	1 1/2", 1 1/4" & 1 1/8"	103	2 1/2"	67	117 mm., 4 1/2" & 4 1/4"
147	1 1/2" & 1 1/4"	26	1 1/2", 40 mm. & 1 1/4"	106	2 1/2"	68	120 mm. & 4 1/2"
15	1 1/2"	27	1 1/2", 1 1/4" & 1 1/8"	104	72 mm & 2 1/2"	69	4 1/2" & 4 1/4"
17	1 1/2"	28	1 1/2", 42 mm., 1 1/4" & 1 1/8"	105	2 1/2"	70	125 mm. & 4 1/2"
18	1 1/2"	47	1 1/2", 1 1/4", 1 1/8" & 44 mm.	114	2 1/2"	70	127 mm. & 5"
35	2 1 mm., 1 1/2" & 1 1/4"	48	1 1/2" & 1 1/4"	107	2 1/2"	71	5 1/2", 130 mm. & 5 1/4"
20	1 1/2"	49	1 1/2"	108	2 1/2" & 3"	72	5 1/2" & 5 1/4"
21	22 mm.	44	1 1/2", 1 1/4" & 1 1/8"	115	3 1/2"	99	5 1/2" & 135 mm.
22	1 1/2" & 1 1/4"	51	1 1/2" & 47 mm.	109	3 1/2", 3 1/4" & 3 1/8"	99	5 1/2" & 137 mm.
24	1 1/2", 1 1/4" & 1 1/8"	50	1 1/2"	109	80 mm. & 3 1/4"	100	5 1/2", 5 1/4" & 140 mm.
31	24 mm., 1 1/2" & 1 1/4"	57	1 1/2", 1 1/4" & 1 1/8"	113	3 1/2"	64	5 1/2" & 5 1/4"
32	1 1/2"	59	2"	63	3 1/2"	73	5 1/2" & 145 mm.
29	1" & 1 1/4"	58	2 1/2" & 52 mm.	54	3 1/2"	73	5 1/2", 147 mm. & 5 1/4"
33	26 mm., 1 1/2" & 1 1/4"	86	2 1/2"	55	3 1/2"	74	5 1/2", 150 mm. & 5 1/4"
				56	85 mm. & 3 1/2"	75	6"

AGS 2031

EXTERNAL CIRCLIPS

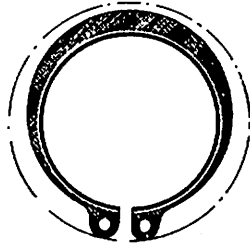

Material:
STEEL
(PHOSPHATE AND OIL)

TABLE OF SIZES

ITEM	TO SUIT SHAFTS OF DIAMETER	ITEM	TO SUIT SHAFTS OF DIAMETER	ITEM	TO SUIT SHAFTS OF DIAMETER
1	12 mm.	23	1 1/8" & 1 1/2"	50	2 1/2" & 3"
2	1"	27	1 1/8", 1 1/2" & 1 3/4"	53	3 1/8", 3 1/2", 80 mm. & 3 3/8"
3	13 mm. & 1 1/8"	28	1 1/2", 1 3/4" & 35 mm.	54	3 1/8", 3 3/8" & 3 1/2"
4	1 1/8", 14 mm. & 1 1/4"	29	1 1/2", 1 3/4", 1 3/4" & 1 1/2"	58	3 1/8", 85 mm. & 3 1/2"
5	15 mm. & 1 1/2"	30	1 3/4", 1 3/4", 40 mm. & 1 3/4"	59	3 1/2" & 90 mm.
6	1" & 16 mm.	31	1 3/4", 1 3/4" & 1 3/4"	60	3 1/2", 95 mm. & 3 1/2"
7	1 1/8", 17 mm., 1 1/2" & 1 1/2"	31	1 1/2" & 1 1/2"	61	3 1/2" & 3 1/2"
11	1 1/8", 18 mm. & 1 1/2"	33	1 1/2", 1 1/2" & 1 1/2"	62	100 mm., 3 1/2" & 4"
9	1 1/8", 19 mm. & 1"	33	1 1/2" & 45 mm.	63	4 1/8", 4 1/2" & 105 mm.
8	1 1/8" & 20 mm.	19	1 1/2", 1 1/2" & 1 1/2"	64	4 1/8" & 4 1/2"
10	1 1/8", 21 mm. & 1 1/2"	34	1 1/2", 1 1/2", 1 1/2" & 1 1/2"	65	4 1/8", 110 mm. & 4 1/2"
12	1 1/8", 22 mm. & 1"	21	1 1/2", 50 mm. & 1 1/2"	66	4 1/8", 4 1/2", 115 mm. & 4 1/8"
14	1 1/8", 1 1/2", 24 mm. & 1 1/2"	35	2"	67	4 1/2", 120 mm., 4 1/2" & 4 1/2"
16	1 1/8", 25 mm. & 1 1/2"	32	2 1/8" & 2 1/4"	68	4 1/2", 125 mm., 4 1/2" & 5"
18	1"	36	2 1/8", 55 mm. & 2 1/8"	69	5 1/8", 130 mm., 5 1/2" & 5 1/8"
20	20 mm. & 1 1/8"	37	2 1/8" & 2 1/4"	70	5 1/2", 5 1/8" & 135 mm.
22	1 1/8" & 27 mm.	38	2 1/8", 2 1/4", 60 mm. & 2 1/4"	71	5 1/8", 5 1/2", 140 mm. & 5 1/8"
24	1 1/8", 28 mm., 1 1/4"	40	2 1/8", 2 1/4" & 2 1/4"	72	5 1/2", 145 mm. & 5 1/2"
24	1 1/2", 1 1/4" & 29 mm.	42	2 1/2", 65 mm. & 2 1/8"	74	5 1/2"
25	1 1/2", 30 mm. & 1 1/8"	46	2 1/2", 2 1/2" & 70 mm.	80	5 1/2", 150 mm. & 5 1/2"
26	1 1/8", 1 1/2", 1 1/2" & 1 1/2"	49	2 1/2", 2 1/2" & 75 mm.	73	6"

AGS 2034

LOCKWASHERS

"Shakeproof." Flat—External Teeth

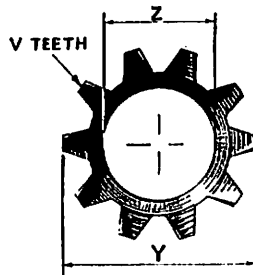

Material : HIGH CARBON SPRING STEEL

Finish : OIL BLACKED

MARK	SCREW SIZE	Z	Y	V
A	6 BA	IN. 0·123	IN. 0·255	8
		0·116	0·245	
B	4 BA	0·153	0·317	12
		0·145	0·306	
C	2 BA	0·204	0·406	12
		0·195	0·395	
E	¼" BSF	0·265	0·506	12
		0·255	0·494	
G	⅜" BSF	0·332	0·601	12
		0·320	0·588	
J	⅝" BSF	0·396	0·695	12
		0·382	0·680	
L	⅞" BSF	0·461	0·791	11
		0·446	0·771	
N	1" BSF	0·529	0·882	12
		0·512	0·862	
P	1⅛" BSF	0·594	0·980	14
		0·576	0·960	
Q	1⅝" BSF	0·660	1·075	12
		0·638	1·055	

Brown Brothers Engineering Ltd

AGS 2035

LOCKWASHERS

"Shakeproof." Flat-Internal Teeth

Material : HIGH CARBON SPRING STEEL

Finish : OIL BLACKED

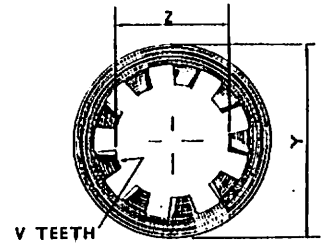

MARK	SCREW SIZE	Z	Y	V
AA	8 BA	IN. 0·095	IN. 0·185	6
		0·089	0·175	
A	6 BA	0·120	0·255	6
		0·113	0·245	
B	4 BA	0·153	0·305	6
		0·145	0·295	
C	2 BA	0·199	0·406	8
		0·190	0·395	
E	¼" BSF	0·267	0·478	8
		0·256	0·466	
G	⅙" BSF	0·332	0·607	8
		0·320	0·594	
J	⅜" BSF	0·396	0·695	9
		0·382	0·680	
L	7/16" BSF	0·461	0·791	10
		0·446	0·771	
N	½" BSF	0·529	0·883	10
		0·512	0·867	
P	⅝" BSF	0·594	0·980	12
		0·576	0·960	
Q	⅞" BSF	0·660	1·075	12
		0·638	1·055	

Brown Brothers Engineering Ltd

AGS 2036

LOCKWASHERS

"Shakeproof." Countersunk—External Teeth

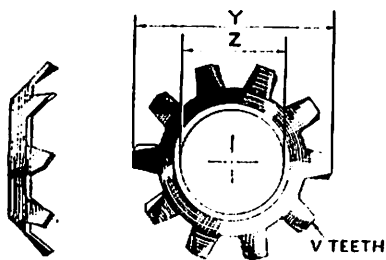

Material : HIGH CARBON SPRING STEEL

Finish : OIL BLACKED

MARK	SCREW SIZE	Z	Y	V
B	4 BA	IN.	IN.	7
		0.153	0.305	
		0.145	0.290	
C	2 BA	0.204	0.377	8
		0.195	0.360	

AGS 2037

LOCKWASHERS

"Shakeproof." Flat—Internal Teeth

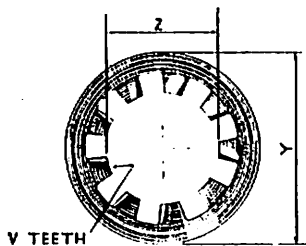

Material : PHOSPHOR BRONZE

Finish : CADMIUM OR ELECTRO-TINNED

MARK	SCREW SIZE	Z	Y	V
AA	8 BA	IN.	IN.	6
		0.095	0.185	
		0.089	0.175	
A	6 BA	0.120	0.255	6
		0.113	0.245	
B	4 BA	0.153	0.305	6
		0.145	0.295	
C	2 BA	0.204	0.400	8
		0.195	0.395	
E	1/4" BSF	0.267	0.478	8
		0.256	0.466	

AGS 2080 & 2081

PIPE CLIP FOR 3/16" DIA. FIXING

Material : ALUMINIUM ALLOY (COLOURED ANODISED) RUBBER COVERED

AGS 2080 Plain AGS 2081 with earthing tongue

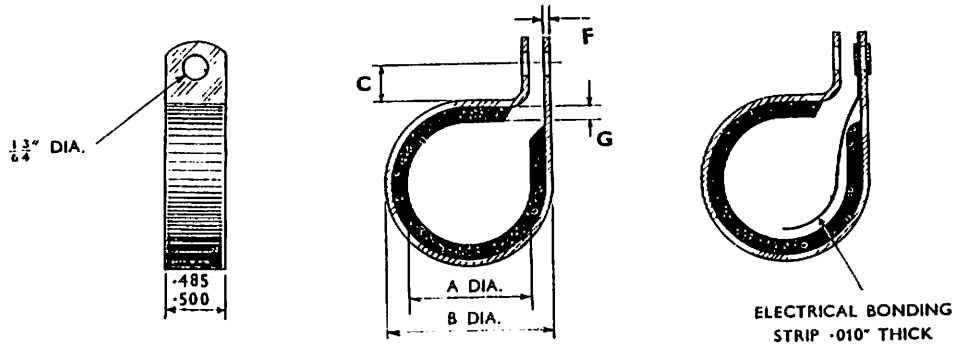

FREM	A DIA.	B DIA.	C	F	G
3	3/16"	IN. 0.389	IN. 0.25	20 SWG	IN. 0.06
4	1/4"	0.452	0.25	20 SWG	0.06
5	5/16"	0.554	0.25	20 SWG	0.08
6	3/8"	0.617	0.25	20 SWG	0.08
7	7/16"	0.679	0.25	20 SWG	0.08
8	1/2"	0.742	0.25	20 SWG	0.08
9	9/16"	0.878	0.30	18 SWG	0.10
10	5/8"	0.941	0.30	18 SWG	0.10
12	3/4"	1.066	0.30	18 SWG	0.10
14	7/8"	1.191	0.30	18 SWG	0.10
16	1"	1.316	0.30	18 SWG	0.10
18	1 1/8"	1.441	0.30	18 SWG	0.10
20	1 1/4"	1.566	0.30	18 SWG	0.10
22	1 3/8"	1.691	0.30	18 SWG	0.10

Brown Brothers Engineering Ltd

AGS 2082 & 2083 PIPE CLIP FOR 1/4" DIA. FIXING

Material : ALUMINIUM ALLOY (COLOURED ANODISED) RUBBER COVERED

AGS 2082 Plain. (Items 28, 30 & 32 replaced by AGS 3431, items 28, 30 & 32).

AGS 2083 With Earthing Tongue. (Items 28, 30 & 32 replaced by AGS 3432, items 28, 30 & 32)

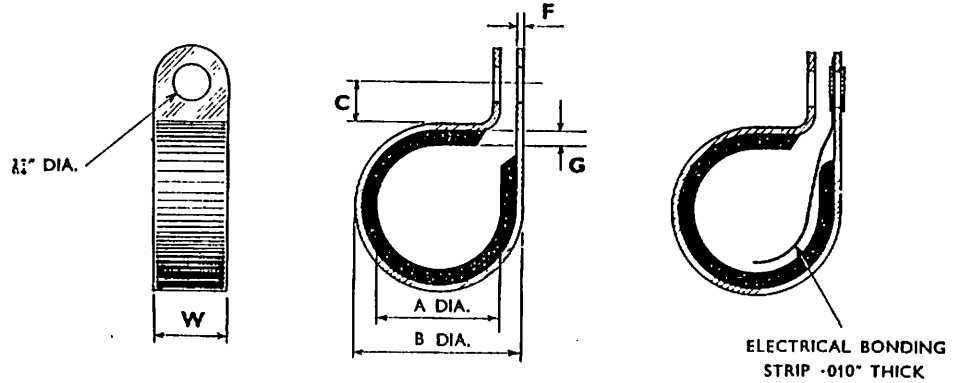

ITEM	A DIA.	B DIA.	C	G	F	W
3	3/16"	IN. 0.389	IN. 0.25	IN. 0.06	20 SWG	0.502 0.547
4	1/4"	0.452	0.25	0.06	20 SWG	
5	5/16"	0.551	0.25	0.08	20 SWG	
6	3/8"	0.617	0.25	0.08	20 SWG	
7	7/16"	0.679	0.25	0.08	20 SWG	
8	1/2"	0.742	0.25	0.08	20 SWG	
9	9/16"	0.878	0.30	0.10	18 SWG	
10	5/8"	0.941	0.30	0.10	18 SWG	
12	3/4"	1.066	0.30	0.10	18 SWG	
14	7/8"	1.191	0.30	0.10	18 SWG	
16	1"	1.316	0.30	0.10	18 SWG	0.625 0.605
18	1 1/8"	1.441	0.30	0.10	18 SWG	
20	1 1/4"	1.566	0.35	0.10	16 SWG	
22	1 1/2"	1.691	0.35	0.10	16 SWG	
24	1 3/4"	1.890	0.35	0.12	16 SWG	
26	1 7/8"	2.020	0.35	0.12	16 SWG	

Brown Brothers Engineering Ltd

AGS 2085

OUTER SLEEVES

SPECIAL NON-REVERSIBLE COUPLINGS TYPE

Working Pressure:
 3,000 lb./sq. in.—Up to $\frac{1}{2}$ "
 500 lb./sq. in.— $\frac{5}{8}$ " to 1"
 200 lb./sq. in.—1 $\frac{1}{4}$ " to 2"
 100 lb./sq. in.—2 $\frac{1}{2}$ "

Material:
 ALUMINIUM ALLOY
 (ANODISED)

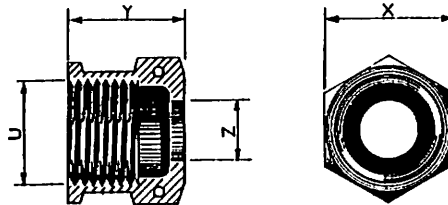

Items "A" to "H" manufactured from hexagonal bar.
 Items "J" to "P" manufactured from round bar.

ITEM	O/D OF PIPE	U THREAD	X A/F		Y	Z DIA.
			MIN.	MAX.		
A						
*B	$\frac{1}{2}$ "	$\frac{1}{2}$ " BSPF	0.595"	0.600"	0.900"	$\frac{3}{8}$ "
BB						
C	$\frac{3}{8}$ "	$\frac{3}{8}$ " BSPF	0.815"	0.820"	0.840"	$\frac{11}{32}$ "
CC						
D	$\frac{1}{2}$ "	$\frac{1}{2}$ " BSPF	1.002"	1.010"	0.880"	$\frac{11}{32}$ "
E	$\frac{5}{8}$ "	$\frac{5}{8}$ " BSPF	1.092"	1.100"	1.020"	$\frac{11}{32}$ "
F	$\frac{3}{4}$ "	$\frac{3}{4}$ " BSPF	1.192"	1.200"	1.070"	$\frac{11}{32}$ "
G	$\frac{7}{8}$ "	$\frac{7}{8}$ " BSPF	1.382"	1.390"	1.110"	$\frac{11}{32}$ "
H	1"	1" BSPF	1.658"	1.670"	1.070"	1 $\frac{1}{32}$ "
			DIA.			
J	1 $\frac{1}{4}$ "	1 $\frac{1}{4}$ " BSPF	2.140"	2.160"	1.070"	1 $\frac{3}{32}$ "
K	1 $\frac{1}{2}$ "	1 $\frac{1}{2}$ " BSPF	2.140"	2.160"	1.310"	1 $\frac{3}{32}$ "
M	2"	2" BSPF	2.940"	2.960"	1.650"	2 $\frac{1}{32}$ "
P	2 $\frac{1}{2}$ "	2 $\frac{1}{2}$ " BSPF	3.680"	3.600"	1.870"	2 $\frac{11}{32}$ "

*Item "B" cancelled. Replaced by AGS. 3414.

Brown Brothers Engineering Ltd

AGS 2096

CHARGING VALVE

AIR & MINERAL BASE HYDRAULIC FLUID

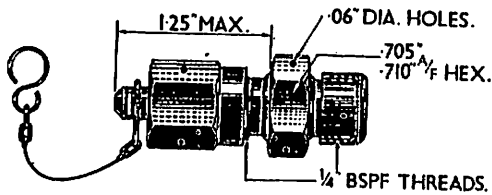

... TYPE A
... Damic Ltd.

... TYPE B
... High Pressure Components Ltd.

AGS 2097

FLEXIBLE BONDING

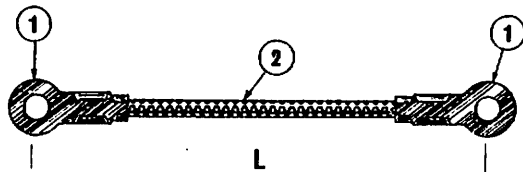

ITEM	DESCRIPTION
1	Closed end tag (see table).
2	Flexible tinned copper braid 12/5/0-0048".

ITEM 1	
CODE	To SUIT BOLT SIZE
B	4 BA or No. 6 UNC.
C	2 BA or No. 10 UNF.
E	1/4" BSF or 1/4" UNF.
G	5/8" BSF or 5/8" UNF.
J	3/4" BSF or 3/4" UNF.

METHOD OF ORDERING

Length "L" in 1" increments (minimum length 3"). A 4" bonding flexible with No. 6 U.N.C. or 4 B.A. ends is A.G.S. 2097B 4B. A 4" bonding flexible with a 4 B.A. or No. 6 U.N.C. end and 1/4" B.S.F. or 1/4" U.N.F. end is A.G.S. 2097 B4E. The smaller end must always be quoted first.

AGS 2100 HIGH TEMPERATURE BONDING LEADS

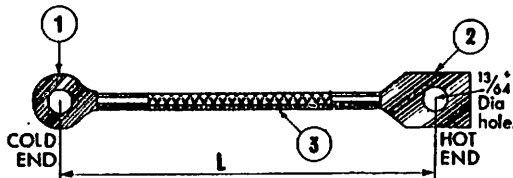

ITEM	DESCRIPTION
1	Tinned copper tag (see table).
2	Nickel tag.
3	80 parallel strands of 40 S.W.G. nickel wire in a woven cover of 41 S.W.G. monel wire.

Suitable for temperatures up to 500° C. Can be attached to aluminium structure without electrolytic corrosion occurring. For use with bonding clip AGS 2104.

ITEM 1	
CODE	To SUIT BOLT SIZE
B	4 BA or No. 6 UNC.
C	2 BA or No. 10 UNF.
E	1/4" BSF or UNF.
G	5/8" BSF or UNF.
J	3/4" BSF or UNF.

METHOD OF ORDERING

Length "L" in 1" increments.
Minimum length: 3". Maximum length: 6".
Example: A 4" bonding lead with 4 B.A. end, is AGS 2100/B/4.

AGS 2101

PIPE SUPPORT CLIP

SUITABLE FOR TEMPERATURES UP TO 500° C.

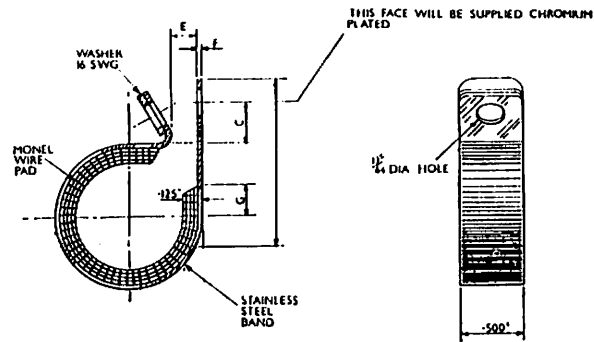

ITEM	TO SUPT PIPE DIA.	G INS.	E INS.	F	G INS.
11	1"	0.300	0.250	22 S.W.G.	0.500
12	1 1/8"	0.300	0.250		0.500
13	1 1/4"	0.300	0.250		0.500
14	1 1/2"	0.300	0.250		0.500
15	1 3/4"	0.300	0.350		0.500
16	1 7/8"	0.300	0.350		0.500
17	2"	0.300	0.350		0.750
18	2 1/8"	0.300	0.350		0.750
19	2"	0.400	0.400	20 S.W.G.	0.750
20	2 1/4"	0.400	0.400		0.750
21	2 1/2"	0.400	0.400		1.000
22	2 3/4"	0.400	0.400		1.000
23	3"	0.400	0.500		1.250
24	3 1/4"	0.400	0.500		1.250
25	3 1/2"	0.400	0.500		1.250
26	3 3/4"	0.400	0.500		1.500
27	4"	0.400	0.500		1.500
28	4 1/4"	0.400	0.500		1.750
29	4 1/2"	0.400	0.500		1.750

AGS 2104

**PIPE BONDING & SUPPORT CLIP
SUITABLE FOR TEMPERATURES UP TO 500° C**

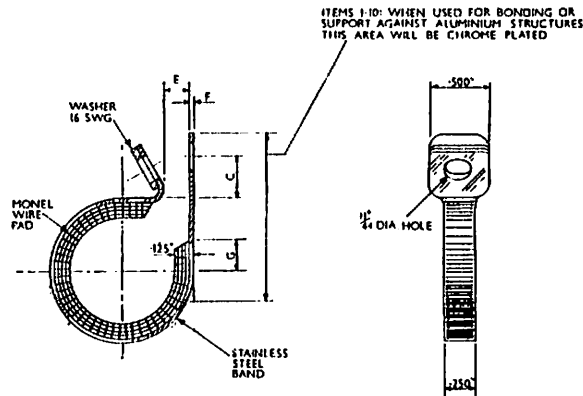

ITEM	TO SUIT PIPE DIA.	C IN.	E IN.	F	G IN.
1	3/8"	0.250	0.100	22 S.W.G.	0.200
2	1/2"	0.250	0.100		0.200
3	3/4"	0.250	0.150		0.200
4	1"	0.250	0.150		0.200
5	1 1/8"	0.250	0.150		0.200
6	1 1/4"	0.250	0.150		0.200
7	1 1/2"	0.300	0.150		0.250
8	1 3/4"	0.300	0.150		0.250
9	2"	0.300	0.150		0.375
10	2 1/4"	0.300	0.150		0.375
11	2 1/2"	0.300	0.250		0.500
12	2 3/4"	0.300	0.250		0.500
13	3"	0.300	0.250		0.500
14	3 1/4"	0.300	0.250		0.500
15	3 1/2"	0.300	0.350		0.500
16	3 3/4"	0.350	0.350		0.500
17	4"	0.350	0.350		0.750
18	4 1/4"	0.350	0.350		0.750
19	2"	0.350	0.400	20 S.W.G.	0.750
20	2 1/4"	0.400	0.400		0.750
21	2 1/2"	0.400	0.400		1.000
22	2 3/4"	0.400	0.400		1.000
23	3"	0.400	0.500		1.250
24	3 1/4"	0.400	0.500		1.250
25	3 1/2"	0.400	0.500		1.250
26	3 3/4"	0.400	0.500		1.500
27	4"	0.400	0.500		1.500
28	4 1/4"	0.400	0.500		1.750
29	4 1/2"	0.400	0.500		1.750

Brown Brothers Engineering Ltd

AGS 2105

'PIP' PINS. PUSH-PULL

AVAILABLE DIAMETERS: $\frac{1}{4}$ ", $\frac{5}{16}$ ", $\frac{3}{8}$ ", $\frac{7}{16}$ ", $\frac{1}{2}$ ", $\frac{9}{16}$ ", $\frac{5}{8}$ ", $\frac{3}{4}$ ", $\frac{7}{8}$ " and 1".

AVAILABLE GRIP LENGTHS: 0.3" to 4.0" (in tenths of an inch increments).

Details on application.

AGS 2106

'PIP' PINS. PUSH TYPE WITH HANDLE

AVAILABLE DIAMETERS: $\frac{1}{4}$ ", $\frac{5}{16}$ " and $\frac{3}{8}$ ".

AVAILABLE GRIP LENGTHS: 0.3" to 2.8" (in tenths of an inch increments).

Details on application.

AGS 2107

'PIP' PINS. 3/16" DIA. PULL TYPE

AVAILABLE GRIP LENGTHS: 0.2" to 1.0" (in tenths of an inch increments).

Details on application.

AGS 2108

PROTECTIVE PLUGS

Material: POLYTHENE (Natural).

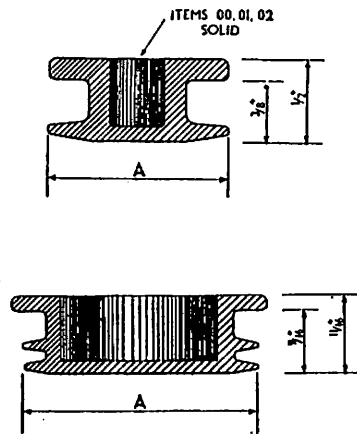

ITEM	SIZE RANGE HOLE DIA.		A DIA.
	FROM	TO	
00	$\frac{1}{8}$ "	$\frac{1}{8}$ "	$\frac{1}{8}$ "
01	$\frac{1}{8}$ "	$\frac{3}{8}$ "	$\frac{3}{8}$ "
02	$\frac{1}{8}$ "	$\frac{1}{2}$ "	$\frac{1}{2}$ "
03	$\frac{1}{8}$ "	1"	1"
04	1 $\frac{1}{8}$ "	1 $\frac{1}{4}$ "	1 $\frac{1}{4}$ "
05	1 $\frac{1}{8}$ "	1 $\frac{1}{2}$ "	1 $\frac{1}{2}$ "
06	1 $\frac{1}{8}$ "	1 $\frac{3}{4}$ "	1 $\frac{3}{4}$ "
07	1 $\frac{1}{8}$ "	1 $\frac{7}{8}$ "	1 $\frac{7}{8}$ "
08	1 $\frac{1}{8}$ "	1 $\frac{7}{8}$ "	1 $\frac{7}{8}$ "
09	1 $\frac{1}{8}$ "	1 $\frac{7}{8}$ "	1 $\frac{7}{8}$ "
010	1 $\frac{1}{8}$ "	1 $\frac{7}{8}$ "	1 $\frac{7}{8}$ "
011	1 $\frac{1}{8}$ "	2"	2"
012	2 $\frac{1}{8}$ "	2 $\frac{1}{4}$ "	2 $\frac{1}{4}$ "
013	2 $\frac{1}{8}$ "	2 $\frac{1}{2}$ "	2 $\frac{1}{2}$ "
014	2 $\frac{1}{8}$ "	2 $\frac{3}{4}$ "	2 $\frac{3}{4}$ "
015	2 $\frac{1}{8}$ "	2 $\frac{3}{4}$ "	2 $\frac{3}{4}$ "

Brown Brothers Engineering Ltd

AGS 2109

PROTECTIVE PLUGS

Material:
P.V.C. or POLYTHENE
(PIGMENTED RED)

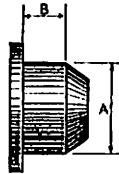

ITEM	SUITABLE FOR THREADS	A	B
01	1" BSPF	0.337"	0.250"
02	1" BSPF	0.451"	0.250"
04	1" BSPF	0.589"	0.500"
05	1" BSPF	0.734"	0.500"
06	1" BSPF	0.811"	0.500"
07	1" BSPF	0.950"	0.500"
08	1" BSPF	1.098"	0.750"
09	1" BSPF	1.193"	0.750"
010	1 1/4" BSPF	1.534"	0.875"
011	1 1/4" BSPF	1.766"	0.875"
012	1 1/2" BSPF	2.000"	1.000"
013	2" BSPF	2.231"	1.000"

AGS 2110

COVERS FOR 20° FLANGES

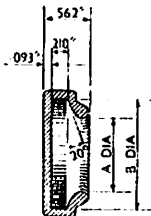

Material:
RUBBER
(NATURAL)

ITEM	A DIA.	B DIA.	ITEM	A DIA.	B DIA.	ITEM	A DIA.	B DIA.
8	0.500"	1.000"	25	2.025"	3.125"	58	6.500"	7.000"
9	0.625"	1.125"	26	2.750"	3.250"	58	6.750"	7.250"
10	0.750"	1.250"	28	3.000"	3.500"	60	7.000"	7.500"
11	0.875"	1.375"	30	3.250"	3.750"	62	7.250"	7.750"
12	1.000"	1.500"	32	3.500"	4.000"	64	7.500"	8.000"
13	1.125"	1.625"	34	3.750"	4.250"	66	7.750"	8.250"
14	1.250"	1.750"	36	4.000"	4.500"	68	8.000"	8.500"
15	1.375"	1.875"	38	4.250"	4.750"	70	8.250"	8.750"
16	1.500"	2.000"	40	4.500"	5.000"	72	8.500"	9.000"
17	1.625"	2.125"	42	4.750"	5.250"	74	8.750"	9.250"
18	1.750"	2.250"	44	5.000"	5.500"	76	9.000"	9.500"
19	1.875"	2.375"	46	5.250"	5.750"	78	9.250"	9.750"
20	2.000"	2.500"	48	5.500"	6.000"	80	9.500"	10.000"
21	2.125"	2.625"	50	5.750"	6.250"	82	9.750"	10.250"
22	2.250"	2.750"	52	6.000"	6.500"	84	10.000"	10.500"
23	2.375"	2.875"	54	6.250"	6.750"	86	10.250"	10.750"
24	2.500"	3.000"						

Brown Brothers Engineering Ltd

AGS 2111

OUTER SLEEVE

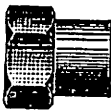

Material: ALUMINIUM ALLOY (ANODISED).

Across Flats: 0.705"/0.710". Threads: 1/4" B.S.P.F.

Overall Length: 0.760".

Replacing AGS 904 Item B.

Working Pressure: 3,000 lb./sq. in.

AGS 2112

PROTECTION PLUG

Material: ALUMINIUM—30 S.W.G. (SELF).

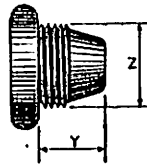

ITEM	A	B	BB	C	CC	D	E	F	G	H	J	K
Z BSPF	1/4"	1/4"	6" x 19	1/4"	0.75" x 14	1/4"	1/4"	1/4"	1/4"	1"	1 1/4"	1 1/4"
Y	0.47"	0.52"	0.55"	0.56"	0.61"	0.64"	0.76"	0.83"	0.88"	0.83"	0.77"	0.97"

Intended for use with pipe assemblies AGS 1100.

AGS 2113

PROTECTION PLUG

Material: ALUMINIUM—30 S.W.G. (SELF).

Intended for use with hose assemblies and AGS 1100 fittings.

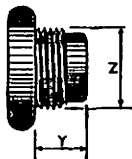

ITEM	A	B	C	D
Z BSPF	1/4"	1/4"	1/4"	1/4"
Y	0.22"	0.25"	0.38"	0.38"

Use AGS 595 for sizes above 1/4" B.S.P.F.

Brown Brothers Engineering Ltd

AGS 2118

SHALLOW SEALING CAP

FOR INHIBITED UNITS

Material: CAP: 30 S.W.G. ALUMINIUM. (SELF)
WASHER: SYNTHETIC RUBBER.

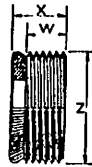

ITEM	W	X	Z—D.S.P.
A	0·160"	0·236"	1"
B	0·250"	0·360"	1"
BB	0·273"	0·377"	0·60" dia. Whit. form
C	0·273"	0·380"	1"
CC	0·350"	0·440"	0·75" dia. Whit. form
D	0·320"	0·440"	1"
E	0·309"	0·440"	1"
F	0·350"	0·480"	1"
G	0·350"	0·480"	1"
H	0·370"	0·500"	1"
J	0·340"	0·500"	1½"
K	0·470"	0·630"	1½"
L	0·500"	0·750"	1½"
M	0·500"	0·750"	2"

AGS 2119

DEEP SEALING CAP

FOR INHIBITED UNITS

Material: CAP: 30 S.W.G. ALUMINIUM. (SELF)
WASHER: SYNTHETIC RUBBER.

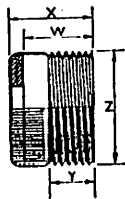

ITEM	W	X	Y	Z—D.S.P.
A	0·400"	0·550"	0·230"	1"
B	0·540"	0·650"	0·400"	1"
BB	0·500"	0·700"	0·400"	0·60" dia. Whit. form
C	0·640"	0·750"	0·400"	1"
CC	—	—	—	—
D	0·746"	0·850"	0·550"	1"

AGS 2120

PIPE COUPLING NIPPLE

(Superseding in part AGS 1170)

Material: STEEL (CADMIUM).

Working Pressures:

3,000 lb./sq. in. for ½" o/d.
500 lb./sq. in. for ¾" and 1" o/d.
200 lb./sq. in. for 1½" o/d.

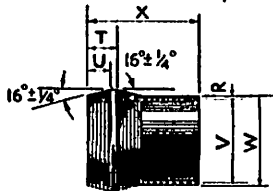

ITEM	O/DIA OF PIPE	R MIN.	T	U	V	W	X
D	1"	0·017"	0·285"	0·235"	1"	0·415"	1·02"
G	1"	0·018"	0·285"	0·235"	1"	0·780"	1·13"
H	1"	0·018"	0·285"	0·235"	1"	0·914"	1·16"
J	1½"	0·025"	0·285"	0·235"	1·100"	1·193"	1·25"

Brown Brothers Engineering Ltd

AGS 3005 to AGS 3007 HIGH DUTY STUDS

Size	AGS	B	C	
1/4" UNF	3005	0.500"	FOR ITEMS 11 & 12 0.400"	FOR ITEMS 13 TO 40 0.500"
5/16" UNF	3006	0.625"	FOR ITEMS 13 TO 15 0.500"	FOR ITEMS 16 TO 45 0.625"
3/8" UNF	3007	0.750"	FOR ITEMS 17 & 18 0.600"	FOR ITEMS 19 TO 50 0.750"



Material: STEEL
(CADMIUM)

Method of calling up is by AGS number followed by "A" length in tenths of an inch. *E.g.* a 1/4" UNF stud "A" length 2.6" is AGS 3005/26.

AGS 3012 & AGS 3016 CONE UNION ADAPTOR UNIFIED ATTACHMENT END

Material: STAINLESS STEEL (SELF)

AGS 3012—FOR USE WITH PARALLEL GASKETS (*e.g.* BONDED SEALS).

AGS 3016—FOR USE WITH "O" RING GASKETS IN AMERICAN (AND 10050) OR EQUIVALENT AGS 3018 TAPPED BOSSES

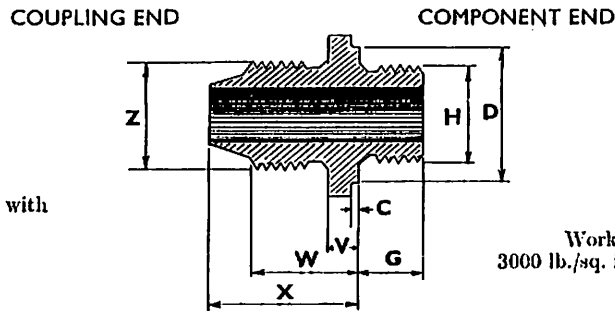

Alternative range of parts with locking wire holes: see AS8580 and AS8591

Working Pressure:
3000 lb./sq. in. up to 1/2" B.S.P.F.

ITEM	O/D OF PIPE	Z THREAD SIZE	COUPLING END—BSP					COMPONENT END—UNIFIED			
			A/F		V	W	X	H THREAD SIZE	C	D	G
			MIN.	MAX.							
A	1/8"	1/4" BSP	IN. 0.6170	IN. 0.6250	IN. 0.20	IN. 0.635	IN. 0.855	1/4" UNF	IN. 0.025	IN. 0.610	IN. 0.35
B	1/4"	1/4" BSP	0.6759	0.6875	0.20	0.665	0.945	5/16" UNF	0.025	0.670	0.40
BB	1/8"	0.600 x 19 TPI Whit. Form	0.7420	0.7500	0.20	0.685	1.005	1/4" UNF	0.025	0.730	0.40
C	1/2"	3/4" BSP	0.8045	0.8125	0.22	0.755	1.075	3/8" UNF	0.025	0.790	0.45
CC											
D	1/2"	1/2" BSP	0.9920	1.0000	0.22	0.825	1.145	1/2" UNF	0.025	0.980	0.50

Brown Brothers Engineering Ltd

AGS 3013 & AGS 3017

UNION ADAPTOR UNIFIED ATTACHMENT END

Material: STAINLESS STEEL (SELF)

COUPLING END

COMPONENT END

Working Pressure:

3000 lb./sq. in. up to 1/2" B.S.P.F.

500 lb./sq. in. 3/4"-1" B.S.P.F.

200 lb./sq. in. 1 1/4"-2" B.S.P.F.

Alternative range of parts with locking wire holes: see AS8590 and AS8592

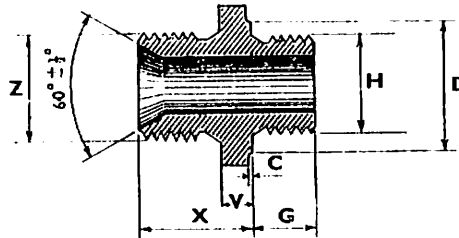

AGS 3013: FOR USE WITH PARALLEL GASKETS (e.g. BONDED SEALS).

AGS 3017: FOR USE WITH "O" RING GASKETS IN AMERICAN (AND 10050) OR EQUIVALENT AGS3018 TAPPED BOSSES.

ITEM	O/D OF PIPE	COUPLING END-- BSP					COMPONENT END-- UNIFIED			
		Z THREAD SIZE	A/F		V	X	H THREAD SIZE	C	D	G
			MIN.	MAX.						
A	3/16"	1/2" BSP	IN. 0.6170	IN. 0.6250	IN. 0.20	IN. 0.65	3/8" UNF	IN. 0.025	IN. 0.61	IN. 0.35
B	1/4"	1/2" BSP	0.6795	0.6875	0.20	0.65	7/16" UNF	0.025	0.67	0.40
BB	5/16"	0.60 O/D x 19 TPI Whit. Form	0.7420	0.7500	0.20	0.72	1/2" UNF	0.025	0.73	0.40
C	3/8"	3/4" BSP	0.8045	0.8125	0.22	0.74	5/8" UNF	0.025	0.79	0.45
CC										
D	1/2"	1/2" BSP	0.9920	1.0000	0.22	0.87	3/4" UNF	0.025	0.98	0.50
E	5/8"	5/8" BSP	1.1150	1.1250	0.24	0.94	7/8" UNF	0.035	1.10	0.55
F	3/4"	3/4" BSP	1.3005	1.3125	0.24	0.99	1 1/16" x 12 UNS	0.035	1.29	0.65
G										
H	1"	1" BSP	1.6100	1.6250	0.26	1.06	1 5/16" x 12 UNS	0.035	1.60	0.65
J	1 1/4"	1 1/4" BSP	DIA.		0.26	1.11	1 5/8" x 12 UNS	0.045	2.00	0.65
			2.14	2.16						
K	1 1/2"	1 1/2" BSP	2.35	2.37	0.26	1.15	1 7/8" x 12 UNS	0.045	2.20	0.65
L	1 3/4"	1 3/4" BSP	2.83	2.85	0.26	1.25	2 1/8" x 12 UNS	0.045	2.70	0.65
M	2"	2" BSP	3.14	3.16	0.26	1.30	2 1/4" x 12 UNS	0.045	3.00	0.65

AGS 3016

CONE UNION ADAPTOR

See AGS 3012

AGS 3017

UNION ADAPTOR

See AGS 3013

Brown Brothers Engineering Ltd

AGS 3020 PROTECTION PLUG (Unified)

Obsolete—replaced by AGS 3802, page 178.

AGS 3021 PROTECTION CAP (Unified)

Obsolete—replaced by AGS 3805, page 179.

AGS 3022 BALL JOINT (Unified)

Material:

ITEMS A and C: H.T. STEEL (CADMIUM).

ITEM B: MILD STEEL (CADMIUM).

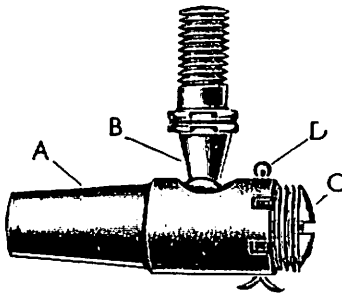

ITEM	PART No.	DESCRIPTION
A	AGS 3023	Socket
B	AGS 3024	Ball Bolt 1/4" UNF
C	AGS 3025	Plug 7/8" x 28 UNS
D	SP 9/C6	Split Pin

AGS 3034 CHARGING VALVE

AIR AND MINERAL BASE HYDRAULIC FLUID

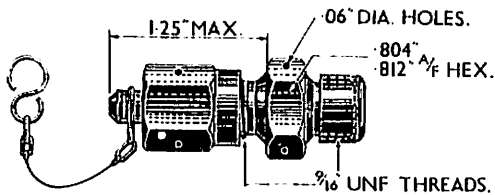

TYPE A

Damic Ltd.

TYPE B

High Pressure Components Ltd.

AGS 3037-3040 BLIND ANCHOR NUT ASSEMBLY

Material: STEEL (CADMIUM)

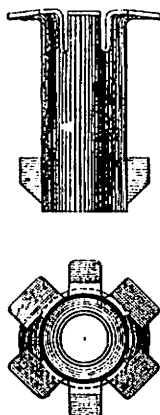

THREAD SIZE	PART NUMBER		
	Up To 0.10" GRIP	0.10" To 0.20" GRIP	0.20" To 0.35" GRIP
4 BA	AGS 3037/1	AGS 3037/2	AGS 3037/3
No. 6 UNC	AGS 3037/4	AGS 3037/5	AGS 3037/6
2 BA	AGS 3038/1	AGS 3038/2	AGS 3038/3
No. 10 UNF	AGS 3038/4	AGS 3038/5	AGS 3038/6
No. 8 UNC	AGS 3038/7	AGS 3038/8	AGS 3038/9
1" BSF	AGS 3039/1	AGS 3039/2	---
1" UNF	AGS 3039/3	AGS 3039/4	---
3/4" BSF	AGS 3040/1		---
3/4" UNF	AGS 3040/3		---

Brown Brothers Engineering Ltd

AGS 3049

BLEEDER SCREW (UNIFIED)

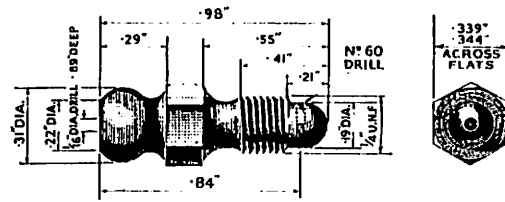

Material:

STEEL (CADMIUM).

WORKING PRESSURE:

3,000 lb./sq. in.

AGS 3050-3069

SPHERICAL BEARING ROD ENDS

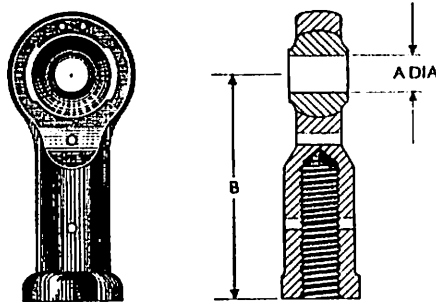

Material:

HOUSING—HIGH TENSILE STEEL
(CADMIUM)

BALL —HARDENED STEEL (CADMIUM)

PART NUMBER	THREAD SIZE	A	B	BALL DIA.	MAX. ANGULAR MOVEMENT	MAX. STATIC LOAD IN LBS.
AGS 3050	No. 6 UNC R.H.	0-112"	0-037"	0-312"	24°	520
AGS 3051	No. 6 UNC L.H.	0-112"	0-037"	0-312"	24°	520
AGS 3052	No. 8 UNC R.H.	0-138"	1-000"	0-343"	10°	830
AGS 3053	No. 8 UNC L.H.	0-138"	1-000"	0-343"	10°	830
AGS 3054	No. 10 UNF R.H.	0-164"	1-187"	0-408"	20°	1,210
AGS 3055	No. 10 UNF L.H.	0-164"	1-187"	0-408"	20°	1,210
AGS 3056	1" UNF R.H.	0-190"	1-437"	0-500"	20°	2,250
AGS 3057	1" UNF L.H.	0-190"	1-437"	0-500"	20°	2,250
AGS 3058	1/8" UNF R.H.	0-250"	1-087"	0-025"	22°	3,600
AGS 3059	1/8" UNF L.H.	0-250"	1-087"	0-025"	22°	3,600
AGS 3060	1" UNF R.H.	0-3125"	1-037"	0-720"	21°	5,540
AGS 3061	1" UNF L.H.	0-3125"	1-037"	0-720"	21°	5,540
AGS 3062	1" UNF R.H.	0-375"	2-502"	0-937"	22°	10,150
AGS 3063	1" UNF L.H.	0-375"	2-502"	0-937"	22°	10,150
AGS 3064	1/2" UNF R.H.	0-500"	3-125"	1-250"	22°	16,400
AGS 3065	1/2" UNF L.H.	0-500"	3-125"	1-250"	22°	16,400
AGS 3066	3/4" UNF R.H.	0-625"	3-087"	1-437"	21°	23,900
AGS 3067	3/4" UNF L.H.	0-625"	3-087"	1-437"	21°	23,900
AGS 3068	1" UNF R.H.	0-750"	4-250"	1-600"	10°	32,800
AGS 3069	1" UNF L.H.	0-750"	4-250"	1-600"	10°	32,800

Brown Brothers Engineering Ltd

AGS 3092 PITOT CONNECTOR (Screwed)

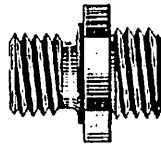

Material: ALUMINIUM ALLOY (ANODISED)

Threads: $\frac{1}{2}$ " \times 26 Whit. and $\frac{7}{16}$ " \times 20 U.N.F.

Across flats: 0.680"/0.688"

AGS 3093 PITOT CONNECTOR (Plain Screwed)

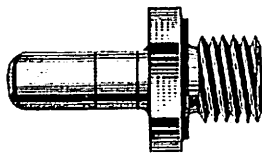

Material: ALUMINIUM ALLOY (ANODISED)

Threads: $\frac{7}{16}$ " \times 20 U.N.F. Diameter of plain end: 0.312"

Across flats: 0.680"/0.688"

AGS 3094 STATIC CONNECTOR (Screwed)

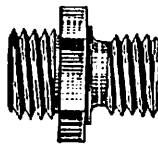

Material: ALUMINIUM ALLOY (ANODISED)

Threads: $\frac{9}{16}$ " \times 28 U.N.S. and $\frac{1}{2}$ " \times 20 U.N.F.

Across flats: 0.742"/0.750"

AGS 3095 STATIC CONNECTOR (Plain Screwed)

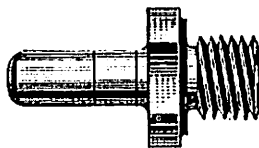

Material: ALUMINIUM ALLOY (ANODISED)

Threads: $\frac{1}{2}$ " \times 20 U.N.F. Diameter of plain end: 0.375"

Across flats: 0.742"/0.750"

Brown Brothers Engineering Ltd

AGS 3096

CONNECTOR $\frac{1}{8}$ " B.S.P.

Obsolete—superseded by AGS 3500.

AGS 3097

CONNECTOR $\frac{3}{8}$ " U.N.F.

Obsolete—superseded by AGS 3501.

AGS 3098 & 3099

GASKET 'O' RING

Material: RUBBER (NATURAL)

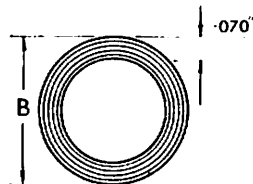

PART No.	B
AGS 3098	0.350"
AGS 3099	0.415"

AGS 3401-3404

LOW PRESSURE UNION ASSEMBLIES

**FOR USE WITH $\frac{5}{16}$ " DIA. TUBING
(UNIFIED THREADS)**

PART No.			
AGS 3401	AGS 3402	AGS 3403	AGS 3404
STRAIGHT OR ELBOW WITH DRAIN TRAP	TEE UNION	ELBOW UNION	STRAIGHT UNION
1 OFF AGS 3406	1 OFF AGS 3406	1 OFF AGS 3407	1 OFF AGS 3405
2 OFF AGS 3412	3 OFF AGS 3412	2 OFF AGS 3412	2 OFF AGS 3412
1 OFF AGS 3408			
1 OFF AGS 3409			

See next page for AGS 3405—3409, 3412

Brown Brothers Engineering Ltd

AGS 3405

STRAIGHT UNION BODY



Material: ALUMINIUM ALLOY (ANODISED)

Across flats: 0.617"/0.625"
Threads: $\frac{1}{2}$ " \times 28 T.P.I. U.N.S.
Overall length: 0.675"

AGS 3406

TEE UNION BODY

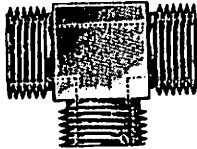

Material: ALUMINIUM ALLOY (ANODISED)

Threads: $\frac{1}{2}$ " \times 28 T.P.I. U.N.S.

AGS 3407

ELBOW UNION BODY

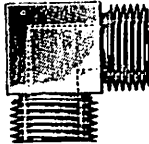

Material: ALUMINIUM ALLOY (ANODISED)

Threads: $\frac{1}{2}$ " \times 28 T.P.I. U.N.S.

AGS 3408

DRAIN TRAP

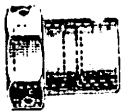

Material: ALUMINIUM ALLOY (ANODISED)

Across flats: 0.742"/0.750"
Threads: $\frac{1}{2}$ " \times 28 T.P.I. U.N.S.
Overall length: 0.825"

AGS 3409

WASHER



Material: RUBBER

Bore: $\frac{5}{16}$ "
Outside diameter: $\frac{1}{2}$ "
Thickness: $\frac{1}{16}$ "

AGS 3412

UNION NUT



Material: ALUMINIUM ALLOY (ANODISED)

plus RUBBER BUSH
Across flats: 0.617"/0.625"
Threads: $\frac{1}{2}$ " \times 28 T.P.I. U.N.S.
Overall length: 0.440"

Brown Brothers Engineering Ltd

AGS 3413

WING NUTS

UNIFIED THREADS

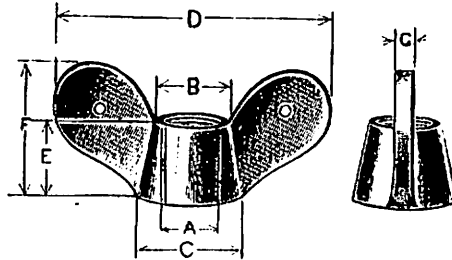

Material:
BRASS (CADMIUM)

No wire holes in items A to D inclusive.

Item No.	A	B	C	D	E	F	G
A	No. 4 × 40 UNC	0.250"	0.280"	1.000"	0.187"	0.500"	0.062"
B	No. 6 × 32 UNC	0.250"	0.280"	1.000"	0.187"	0.500"	0.062"
C	No. 8 × 32 UNC	0.312"	0.340"	1.250"	0.250"	0.625"	0.080"
D	No. 10 × 32 UNF	0.312"	0.340"	1.250"	0.250"	0.625"	0.080"
E	1" UNF	0.375"	0.440"	1.500"	0.310"	0.750"	0.094"
G	5/16" UNF	0.437"	0.520"	1.620"	0.390"	0.812"	0.094"
J	3/4" UNF	0.500"	0.600"	1.750"	0.470"	0.875"	0.094"
L	7/16" UNF	0.562"	0.710"	2.000"	0.550"	1.000"	0.125"
N	1/2" UNF	0.625"	0.820"	2.250"	0.630"	1.250"	0.125"

AGS 3414

OUTER SLEEVE

REPLACING AGS 2085, ITEM B

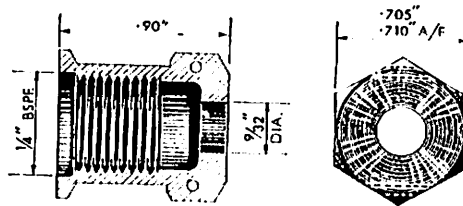

Material:
ALUMINIUM ALLOY (ANODISED)

WORKING PRESSURE.
3,000 lb./sq. in.

Brown Brothers Engineering Ltd

AGS 3420 & 3421 FLANGED MOUNTING

See AGS 3437-3440 assemblies

AGS 3422 STRAIGHT UNION

See AGS 3433 and 3437 assemblies

AGS 3423 ELBOW UNION

See AGS 3434 and 3438 assemblies

AGS 3424 STRAIGHT UNION

See AGS 3435 and 3439 assemblies

AGS 3425 ELBOW UNION

See AGS 3436 and 3440 assemblies

AGS 3429 FLEXIBLE HOSE ASSEMBLY (PITOT)

Material: HOSE—MARICON TYPE H (NATURAL)
END FITTINGS—ALUMINIUM ALLOY (ANODISED)

Thread on end fittings: $\frac{1}{8}$ " \times 26 T.P.I. Whitform
Available in lengths: 6" to 24" Overall

AGS 3430 FLEXIBLE HOSE ASSEMBLY (STATIC)

Material: HOSE—MARICON TYPE H (NATURAL)
END FITTINGS—ALUMINIUM ALLOY (ANODISED)

Thread on end fittings: $\frac{9}{16}$ " \times 28 T.P.I. U.N.S.
Available in lengths: 6" to 24" Overall

Brown Brothers Engineering Ltd

AGS 3431 & 3432 PIPE CLIP FOR 1/4" DIA. FIXING RUBBER COVERED

Material: ALUMINIUM ALLOY (COLOURLESS ANODISED)

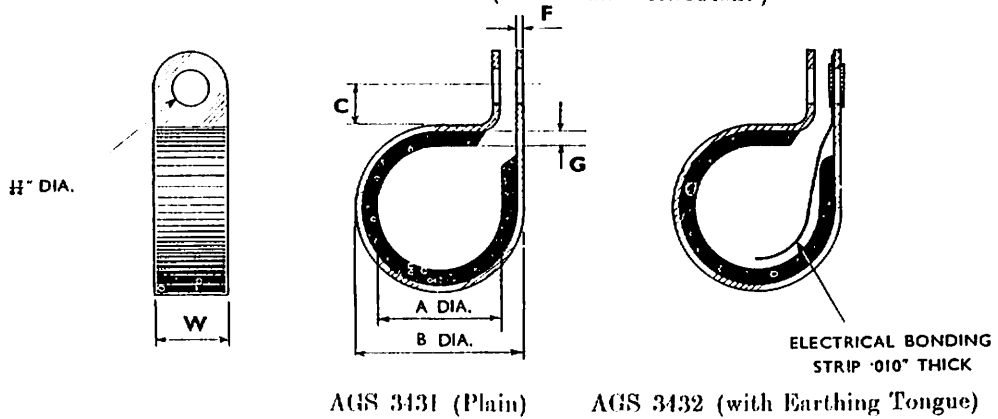

ITEM	A DIA.	B DIA.	C	G	F	W
28	1 1/2"	2.230"	0.50"	0.15"	14 SWG	}
30	1 3/4"	2.355"	0.50"	0.15"	14 SWG	
32	2"	2.480"	0.50"	0.15"	14 SWG	

AGS 3433 & 3435 DRAIN TRAPS

AGS 3433: INTERNAL STRAIGHT UNION PITOT
AGS 3435: INTERNAL STRAIGHT UNION STATIC

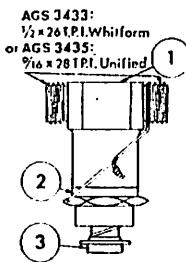

Material: Item 1: ALUMINIUM ALLOY (ANODISED)
Item 2: STEEL and RUBBER Bonded Together
(CADMIUM AND NATURAL)

ITEM	PART No.	DESCRIPTION
1	AGS 3422 or AGS 3424	Straight Union Pitot Straight Union Static
2	AGS 1186/B	Bonded Seal
3	Vickers A5200 Mk. B	1/2" BSPP Drain Cock

AGS 3434 & 3436 DRAIN TRAPS

AGS 3434: INTERNAL ELBOW UNION PITOT
AGS 3436: INTERNAL ELBOW UNION STATIC

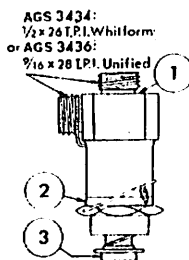

Material: Item 1: ALUMINIUM ALLOY (ANODISED)
Item 2: STEEL and RUBBER Bonded Together
(CADMIUM AND NATURAL)

ITEM	PART No.	DESCRIPTION
1	AGS 3423 or AGS 3425	Elbow Union Pitot Elbow Union Static
2	AGS 1186/B	Bonded Seal
3	Vickers A5200 Mk. B	1/2" BSPP Drain Cock

Brown Brothers Engineering Ltd

AGS 3437 & 3439

DRAIN TRAPS

AGS 3437 : EXTERNAL STRAIGHT UNION PITOT

AGS 3439 : EXTERNAL STRAIGHT UNION STATIC

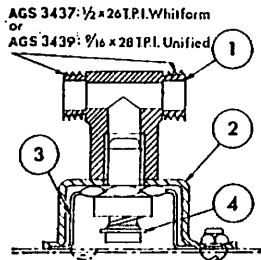

Material: Item 1 and 3 : ALUMINIUM ALLOY (ANODISED)
Item 2 : STEEL AND RUBBER Bonded Together
(CADMIUM AND NATURAL.)

ITEM	PART NO.	DESCRIPTION
1	AGS 3422 or AGS 3424	Straight union pitot Straight union static
2	AGS 3420	Flanged mounting
3	AGS 3421	Locking plate
4	Vickers A 5269 Mk B	1/4" BSPF drain cock

AGS 3438 & 3440

DRAIN TRAPS

AGS 3438 : EXTERNAL ELBOW UNION PITOT

AGS 3440 : EXTERNAL ELBOW UNION STATIC

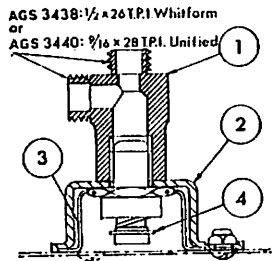

Material: Item 1 and 3 : ALUMINIUM ALLOY (ANODISED)
Item 2 : STEEL AND RUBBER bonded together
(CADMIUM AND NATURAL.)

ITEM	PART NO.	DESCRIPTION
1	AGS 3423 or AGS 3425	Elbow union pitot Elbow union static
2	AGS 3420	Flanged mounting
3	AGS 3421	Locking plate
4	Vickers A 5269 Mk. B	1/4" BSPF drain cock

AGS 3500 & 3501

CONNECTORS

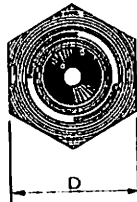
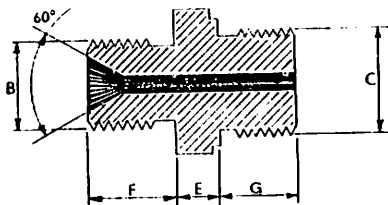

Material:
ALUMINIUM ALLOY (ANODISED)

WORKING PRESSURE
3,000 lb./sq. in.

PART NO.	B THRD.	C THRD.	D A/F		E	F	G
			MIN.	MAX.			
AGS 3500	1" BSPF	3/8" UNF	0.680"	0.688"	0.20"	0.45"	0.40"
AGS 3501	1/2" UNF	3/8" UNF	0.680"	0.688"	0.20"	0.45"	0.40"

Brown Brothers Engineering Ltd

AGS 3800

COVER FOR 10,000 LB LASHING FITTING BASE

Material: ALUMINIUM ALLOY (ANODISED). Details available on request

AGS 3801

COVER FOR 25,000 LB LASHING FITTING BASE

Material: ALUMINIUM ALLOY (ANODISED). Details available on request

AGS 3802, 3803 & 3804 PLUGS (Unified)

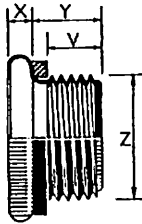

Materials:

Plug: ALUMINIUM, 30 S.W.G.

Seal (Type 1): RUBBER suitable for mineral base hydraulic fluid.

Seal (Type 2): RUBBER suitable for Skydol and Silcodyne H.

AGS 3802: PLUG (no seal)

AGS 3803: PLUG AND SEAL (Type 1)

AGS 3804: PLUG AND SEAL (Type 2)

ITEM	Z EXTERNAL THREAD	V	X	Y
4	1" × 28 UNF	0.09"	0.18"	0.18"
5	5/8" × 24 UNF	0.10"	0.16"	0.18"
6	3/4" × 21 UNF	0.23"	0.16"	0.31"
7	5/8" × 20 UNF	0.26"	0.18"	0.34"
8	1/2" × 20 UNF	0.31"	0.20"	0.39"
9	5/8" × 18 UNF	0.28"	0.26"	0.40"
10	3/4" × 18 UNF	0.28"	0.32"	0.36"
11	1/2" × 20 UNS	0.27"	0.20"	0.35"
12	3/4" × 16 UNF	0.23"	0.18"	0.31"
13	1/2" × 16 UNS	0.27"	0.20"	0.39"
14	3/4" × 14 UNF	0.28"	0.30"	0.40"
17	1 1/8" × 12 UNS	0.42"	0.20"	0.54"
21	1 1/8" × 12 UNS	0.47"	0.20"	0.62"
22	1 3/8" × 12 UNF	0.46"	0.30"	0.61"
26	1 3/8" × 12 UNS	0.48"	0.20"	0.63"
30	1 1/2" × 12 UNS	0.50"	0.20"	0.69"
36	2 1/4" × 12 UNS	0.54"	0.20"	0.73"
40	2 1/4" × 12 UNS	0.54"	0.20"	0.73"

Brown Brothers Engineering Ltd

AGS 3805, 3806 & 3807

CAPS (Unified)

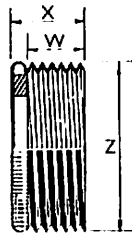

Material:

Cap : ALUMINIUM, 30 S.W.G.

Seal (Type 1) : RUBBER suitable for mineral base hydraulic fluid

Seal (Type 2) : RUBBER suitable for Skydrol and Silcodyne II

AGS 3805 : CAP (no seal)

AGS 3806 : CAP AND SEAL (Type 1)

AGS 3807 : CAP AND SEAL (Type 2)

ITEM	Z INTERNAL THREAD	W	X
5	$\frac{5}{16}$ " \times 24 UNF	0.29"	0.37"
6	$\frac{3}{8}$ " \times 24 UNF	0.27"	0.35"
7	$\frac{7}{16}$ " \times 20 UNF	0.30"	0.38"
8	$\frac{1}{2}$ " \times 20 UNF	0.22"	0.32"
9	$\frac{9}{16}$ " \times 18 UNF	0.27"	0.37"
10	$\frac{5}{8}$ " \times 18 UNF	0.37"	0.47"
11	$\frac{11}{16}$ " \times 20 UNS	0.46"	0.58"
12	$\frac{3}{4}$ " \times 16 UNF	0.33"	0.48"
13	$\frac{13}{16}$ " \times 16 UNS	0.35"	0.47"
14	$\frac{7}{8}$ " \times 14 UNF	0.35"	0.54"
17	$1\frac{1}{16}$ " \times 12 UNS	0.39"	0.51"
21	$1\frac{1}{16}$ " \times 12 UNS	0.42"	0.54"
22	$1\frac{3}{8}$ " \times 12 UNF	0.49"	0.61"
26	$1\frac{5}{8}$ " \times 12 UNS	0.45"	0.55"
30	$1\frac{7}{8}$ " \times 12 UNS	0.49"	0.61"
36	$2\frac{1}{4}$ " \times 12 UNS	0.74"	0.93"
40	$2\frac{1}{2}$ " \times 12 UNS	0.74"	0.93"

AGS 3816

COVER FOR 50,000 LB LASHING FITTING BASE

Material: ALUMINIUM ALLOY (ANODISED). Details available on request

Brown Brothers Engineering Ltd

AGS 3820-3869

BONDED SEALS

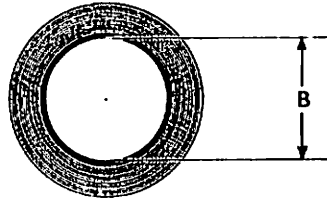
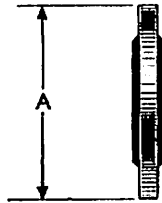

Material:
STEEL & RUBBER
(NITRILE) BONDED
TOGETHER

PART NUMBER	NOM. DIA. OR THRD.	A	B	PART NUMBER	NOM. DIA. OR THRD.	A	B
AGS 3823	0.190"	0.330" 0.335"	0.200" 0.210"	AGS 3841	1.000" & 1" B.S.P.F.	1.375" 1.380"	1.060" 1.068"
AGS 3824	0.250"	0.520" 0.525"	0.265" 0.275"	AGS 3842	1.062"	1.520" 1.525"	1.090" 1.100"
AGS 3825	0.250"	0.525" 0.530"	0.270" 0.280"	AGS 3843	1.125"	1.440" 1.445"	1.150" 1.160"
AGS 3826	0.312"	0.525" 0.530"	0.322" 0.330"	AGS 3844	1.188" & 1" B.S.P.F.	1.500" 1.505"	1.208" 1.216"
AGS 3827	0.312"	0.560" 0.565"	0.335" 0.345"	AGS 3845	1.250"	1.630" 1.635"	1.280" 1.290"
AGS 3828	0.375" & 1/4" B.S.P.F.	0.625" 0.630"	0.403" 0.411"	AGS 3846	1.312" & 1" B.S.P.F.	1.685" 1.690"	1.329" 1.337"
AGS 3829	0.400"	0.723" 0.727"	0.438" 0.442"	AGS 3847	1.375"	1.750" 1.755"	1.410" 1.420"
AGS 3830	0.438"	0.750" 0.755"	0.455" 0.465"	AGS 3848	1.500"	1.880" 1.885"	1.530" 1.540"
AGS 3831	0.500" & 1/2" B.S.P.F.	0.810" 0.815"	0.536" 0.544"	AGS 3849	1.625" & 1 1/2" B.S.P.F.	2.062" 2.067"	1.685" 1.693"
AGS 3832	0.562"	0.875" 0.880"	0.590" 0.580"	AGS 3850	1.750"	2.250" 2.255"	1.780" 1.790"
AGS 3833	0.600"	0.875" 0.880"	0.618" 0.626"	AGS 3851	1.875" & 1 1/2" B.S.P.F.	2.307" 2.312"	1.902" 1.910"
AGS 3834	0.625"	1.000" 1.005"	0.845" 0.855"	AGS 3852	2.000"	2.500" 2.505"	2.030" 2.040"
AGS 3835	3/4" B.S.P.F.	0.937" 0.942"	0.675" 0.685"	AGS 3853	1 1/2" B.S.P.F.	2.750" 2.755"	2.156" 2.164"
AGS 3836	0.688"	1.000" 1.005"	0.710" 0.720"	AGS 3854	2.250"	2.770" 2.775"	2.280" 2.290"
AGS 3837	0.750"	1.060" 1.065"	0.770" 0.778"	AGS 3855	2" B.S.P.F.	2.875" 2.880"	2.380" 2.390"
AGS 3838	0.812" & 1" B.S.P.F.	1.125" 1.130"	0.843" 0.851"	AGS 3856	2.500"	3.060" 3.065"	2.530" 2.540"
AGS 3839	0.875" & 1" B.S.P.F.	1.250" 1.255"	0.920" 0.928"	AGS 3857	2 1/2" B.S.P.F.	3.130" 3.135"	2.620" 2.630"
AGS 3840	0.938"	1.310" 1.315"	0.950" 0.960"	AGS 3858	2 1/2" B.S.P.F.	3.550" 3.560"	2.990" 3.000"

Brown Brothers Engineering Ltd

AGS 3924

**HOSE CLIP—Worm Drive Type
Extra Light duty**

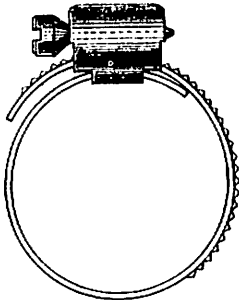

Material:

18/8 AUSTENIC STAINLESS STEEL (SELF)

PART NO.	SUITABLE FOR HOSE OF O/DIA.		WEIGHT LB./100
	MIN.	MAX.	
AGS 3924/1	0.28"	0.43"	0.57
AGS 3924/2	0.43"	0.75"	0.63

AGS 3925

**HOSE CLIP—Worm Drive Type
Light Duty**

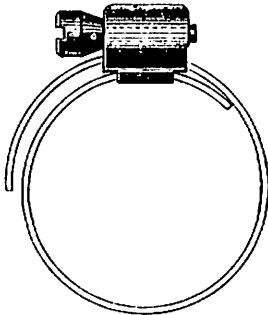

Material:

18/8 AUSTENIC STAINLESS STEEL (SELF)

PART NUMBER	SUITABLE FOR HOSE OF O/DIA.		WEIGHT LB./100
	MIN.	MAX.	
AGS 3925/1	0.43"	0.63"	1.38
AGS 3925/2	0.55"	0.87"	1.51
AGS 3925/00	0.71"	1.10"	1.70
AGS 3925/0	0.94"	1.42"	1.92

BS EQUIVALENTS FOR AGS WORM DRIVE HOSE CLIPS

OUTSIDE DIA. OF HOSE	AGS 605	AGS 1000	SP 91 MILLED BAND	SP 92 PIERCED BAND
1" - 1"	00	00	A	A
1" - 2"	—	—	B	B
1" - 2"	0	0	C	C
2" - 1"	—	—	D	D
2" - 1 1/2"	1A	1A	E	E
1" - 1 1/2"	1	1	F	F
1 1/2" - 1 1/2"	1X	1X	G	G
1 1/2" - 1 1/2"	—	—	H	H
1 1/2" - 2 1/2"	2	2	J	J
1 1/2" - 2 1/2"	—	—	K	K
2" - 2 1/2"	3	3	L	L
2 1/2" - 3 1/2"	—	—	M	M
2 1/2" - 3 1/2"	4	4	N	N
3 1/2" - 4"	5	5	P	P
3 1/2" - 4 1/2"	—	—	Q	Q
4 1/2" - 5"	6	6	R	R

AGS 784, BS SP9 AND BS SP90 EQUIVALENTS

FOR NICKEL ALLOY SPLIT COTTER PINS

OVERALL LENGTH INCLUDING EYE	NOMINAL DIAMETER														
	5/16"			3/64"			1/8"			5/64"			3/32"		
	AGS 784	SP 9	SP90	AGS 784	SP 9	SP90	AGS 784	SP 9	SP90	AGS 784	SP 9	SP90	AGS 784	SP 9	SP90
	NOMINAL LENGTH UNDER EYE - SP90 ONLY														
1/2"		A3	A2 (1")		B3	B2 (1")		C3	C2 (1")						E3
3/4"		A4	A3 (1")	1B	B4	B3 (1")	1	C4	C3 (1")				9	E4	E2 (1")
1"		A5	A4 (1")		B5	B4 (1")	50	C5	C4 (1")					E5	E3 (1")
1 1/4"		A6	A5 (1")	2B	B6	B5 (1")	2	C6	C5 (1")				10	E6	E4 (1")
1 1/2"		A8	A7 (1")	3B	B8	B7 (1")	3	C8	C7 (1")	3A		(1")	11	E8	E6 (1")
1 3/4"		A10	A9 (1")		B10	B9 (1")	4	C10	C9 (1")				12	E10	E8 (1")
2"		A12	A11 (1")		B12	B11 (1")	5	C12	C11 (1")	5A		(1")	13	E12	E10 (1")
2 1/4"		A14	A13 (1")		B14	B13 (1")		C14	C13 (1")					E14	E12 (1")
2 1/2"		A16	A15 (1")		B16	B15 (1")	6	C16	C15 (1")				14	E16	E14 (1")
2 3/4"		A18	A17 (1")		B18	B17 (1")		C18	C17 (1")					E18	E16 (1")
3"		A20	A19 (1")		B20	B19 (1")		C20	C19 (1")					E20	E18 (1")
3 1/4"		A24	A23 (1")		B24	B23 (1")		C24	C23 (1")					E24	E22 (1")

OVERALL LENGTH INCLUDING EYE	NOMINAL DIAMETER														
	7/64"			1"			5/8"			3/4"			1"		
	AGS 784	SP 9	SP90	AGS 784	SP 9	SP90	AGS 784	SP 9	SP90	AGS 784	SP 9	SP90	AGS 784	SP 9	SP90
	NOMINAL LENGTH UNDER EYE - SP90 ONLY														
1 1/4"					G3			H3			K3				
1 1/2"					G4			H4			K4			14	
1 3/4"					G5	G3 (1")		H5			K5			15	
2"				18	G6	G4 (1")	26	H6	H3 (1")		K6	K3 (1")		16	
2 1/4"	11A		(1")	19	G8	G6 (1")	27	H8	H5 (1")	35	K8	K5 (1")	43	L8	L4 (1")
2 1/2"				20	G10	G8 (1")	28	H10	H7 (1")	36	K10	K7 (1")	44	L10	L6 (1")
2 3/4"	13A		(1")	21	G12	G10 (1")	29	H12	H9 (1")	37	K12	K9 (1")	45	L12	L8 (1")
3"					G14	G12 (1")		H14	H11 (1")		K14	K11 (1")		L14	L10 (1")
3 1/4"				22	G16	G14 (1")	30	H16	H13 (1")	38	K16	K13 (1")	46	L16	L12 (1")
3 1/2"					G18	G16 (1")		H18	H15 (1")		K18	K15 (1")		L18	L14 (1")
3 3/4"				23	G20	G18 (1")	31	H20	H17 (1")	39	K20	K17 (1")	47	L20	L16 (1")
4"					G21	G22 (1")		H21	H21 (1")	40	K21	K21 (1")	48	L24	L20 (1")

Brown Brothers Engineering Ltd

AS 103-106 & 111 PULLEYS, BALL BEARING

Material: PLASTIC MOULDING

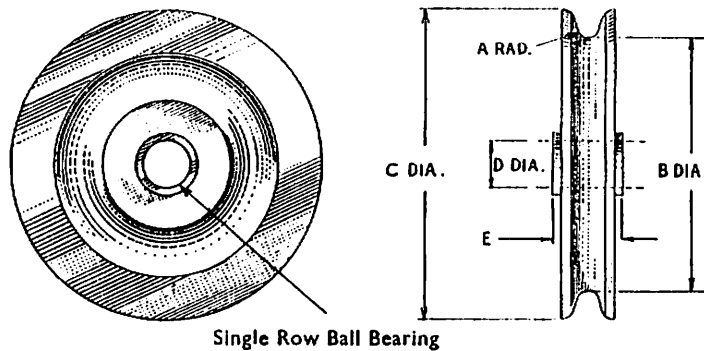

AS 103. 2"

A RAD.	B DIA.	C DIA.	D DIA.	E
0.08"	2"	2.4"	0.375"	0.5"

AS 104. 3"

A RAD.	B DIA.	C DIA.	D DIA.	E
0.1"	3"	3.5"	0.375"	0.5"

AS 105. 4"

A RAD.	B DIA.	C DIA.	D DIA.	E
0.125"	4"	4.6"	0.5"	0.625"

AS 106. 5"

A RAD.	B DIA.	C DIA.	D DIA.	E
0.125"	5"	5.6"	0.5"	0.625"

AS 111. 1.15"

A RAD.	B DIA.	C DIA.	D DIA.	E
0.08"	1.15"	1.4"	0.25"	0.3125"

SHROUDED PULLEYS

Material : PULLEYS and SHROUDS : Plastic Moulding
 BUSH : Brass (SELF-FINISH)
 Cable size 5 cwt.

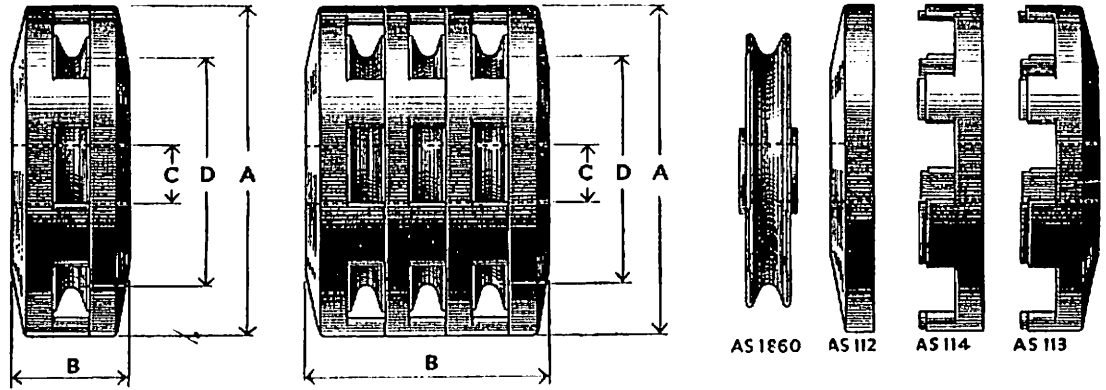

AS 107 & 1151 SINGLE

(PLAIN BEARING) (BALL BEARING)

DIMENSIONS			
A	B	C	D
1.687"	0.625"	0.25"	1.15"
NUMBER OF PARTS REQUIRED			
PLAIN BEARING	AS 1860	AS 112	AS 113
	1	1	1
BALL BEARING	AS 111	AS 112	AS 113
	1	1	1

AS 108 & 1152 DOUBLE

(PLAIN BEARING) (BALL BEARING)

DIMENSIONS				
A	R	C	D	
1.687"	0.937"	0.25"	1.15"	
NUMBER OF PARTS REQUIRED				
PLAIN BEARING	AS 1860	AS 112	AS 113	AS 114
	2	1	1	1
BALL BEARING	AS 111	AS 112	AS 113	AS 114
	2	1	1	1

AS 109 & 1153 TRIPLE

(PLAIN BEARING) (BALL BEARING)

DIMENSIONS				
A	B	C	D	
1.687"	1.25"	0.25"	1.15"	
NUMBER OF PARTS REQUIRED				
PLAIN BEARING	AS 1860	AS 112	AS 113	AS 114
	3	1	1	2
BALL BEARING	AS 111	AS 112	AS 113	AS 114
	3	1	1	2

AS 110 & 1154 QUADRUPLE

(PLAIN BEARING) (BALL BEARING)

DIMENSIONS				
A	R	C	D	
1.687"	1.562"	0.25"	1.15"	
NUMBER OF PARTS REQUIRED				
PLAIN BEARING	AS 1860	AS 112	AS 113	AS 114
	4	1	1	3
BALL BEARING	AS 111	AS 112	AS 113	AS 114
	4	1	1	3

AS 111

PULLEY, BALL BEARING

See page 183

AS 112, 113 & 114

PULLEY SHROUDS

ITEM	AS 112	AS 113	AS 114
DESCRIPTION	Cover	Cover with Spacer	Spacer

Brown Brothers Engineering Ltd

AS 155, 156, 157, 455, 457, 458, 459, 2227 & 4694 SOLID RIVETS—SNAP HEAD

AS 155 replaced by SP 77	AS 457 replaced by SP 81
AS 156 replaced by SP 78	AS 2227 replaced by SP 80
AS 157 replaced by SP 79	AS 4694 replaced by SP 82
AS 455 replaced by SP 76	

AS 158, 159, 2228 SOLID RIVETS—MUSHROOM HEADS

AS 158 replaced by SP 83
AS 159 replaced by SP 84
AS 2228 replaced by SP 85

AS 160, 161, 162, 460, 462, 466, 467, 2229 & 4695 SOLID RIVETS—90° COUNTERSUNK HEAD

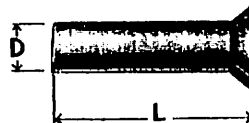

PART NO.	MATERIAL	MIN. ULT. TENSILE STRENGTH	SPECIFICATION	FINISH	IDENTIFICATION
		TONS PER SQ. IN.			
AS 160	Aluminium	7	L36	Anodlo	Black
AS 181	Aluminium Alloy	26	L37	Self	Natural Colour
AS 162	5% Magnesium Aluminium Alloy	16	L58	Anodic	Green
AS 480	Mild Steel	20	BS1109	Cadmium	Magnetic
AS 482	High Nickel Copper Alloy—Monel	28	D.T.D. 201A	Self	Natural Colour
AS 486	Aluminium Nickel Silicon Brass—Tungum	28	D.T.D. 367	Cadmium	—
AS 467	Copper	14	—	Self	Natural Colour
AS 2229	Aluminium Alloy	17	L86	Anodic	Violet
AS 4695	High Nickel Copper Alloy—Monel	28	D.T.D. 201A	Cadmium	—

DIA. D.	$\frac{1}{8}$ "	$\frac{3}{16}$ "	$\frac{1}{4}$ "	$\frac{5}{16}$ "	$\frac{3}{8}$ "	$\frac{7}{16}$ "	$\frac{1}{2}$ "	$\frac{5}{8}$ "	$\frac{3}{4}$ "
DEPTH OF HEAD (IN.)	0.023	0.035	0.047	0.059	0.070	0.082	0.094	0.117	0.141
DIA. OF HEAD (IN.)	0.109	0.161	0.218	0.273	0.328	0.383	0.437	0.517	0.656

Rivets are ordered by the last two figures of the part number denoting the length in $\frac{1}{16}$ " and the remaining figure or figures denoting the dia. in $\frac{1}{32}$ ", e.g. the part reference for a $\frac{1}{4}$ " dia. Rivet $\frac{1}{2}$ " long in Mild Steel would be AS 460/408.

Brown Brothers Engineering Ltd

AS 163, 164, 165, 463, 465, 468, 2230 & 4696 SOLID RIVETS—120° COUNTERSUNK HEAD

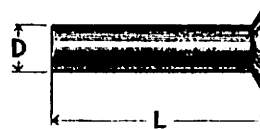

PART NO.	MATERIAL	MIN. ULT. TENSILE STRENGTH TONS PER SQ. IN.	SPECIFICATION	FINISH	IDENTIFICATION
AS 163	Aluminium	7	L36	Anodic	Black
AS 164	Aluminium Alloy	25	L37	Self	Natural Colour
AS 165	5% Magnesium Aluminium Alloy	16	L58	Anodic	Green
AS 463	Mild Steel	20	BS1109	Cadmium	Magnetic
AS 465	High Nickel Copper Alloy—Monel	28	D.T.D. 201A	Self	Natural Colour
AS 468	Aluminium Nickel Silicon Brass—Tungum	28	D.T.D. 367	Cadmium	—
AS 2230	Aluminium Alloy	17	L86	Anodic	Violet
AS 4696	High Nickel Copper Alloy—Monel	28	D.T.D. 201A	Cadmium	—

DIA. D.	$\frac{1}{16}$ "	$\frac{3}{32}$ "	$\frac{1}{4}$ "	$\frac{5}{16}$ "	$\frac{3}{8}$ "	$\frac{7}{16}$ "	$\frac{1}{2}$ "	$\frac{5}{8}$ "	$\frac{3}{4}$ "
DEPTH OF HEAD (IN.)	0.018	0.027	0.036	0.045	0.054	0.063	0.072	0.090	0.108
DIA. OF HEAD (IN.)	0.125	0.188	0.250	0.313	0.375	0.438	0.500	0.625	0.750

Rivets are ordered by the last two figures of the part number denoting the length in $\frac{1}{16}$ " and the remaining figure or figures denoting the dia. in $\frac{1}{32}$ ", e.g. the part reference for a $\frac{1}{4}$ " dia. Rivet $\frac{1}{2}$ " long in Mild Steel would be AS 463/408.

AS 469

FLAT HEAD

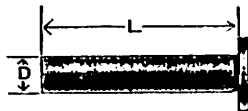

Material: COPPER

DIA. D.	$\frac{1}{16}$ "	$\frac{3}{32}$ "	$\frac{1}{4}$ "	$\frac{5}{16}$ "	$\frac{3}{8}$ "	$\frac{7}{16}$ "	$\frac{1}{2}$ "
DEPTH OF HEAD	0.016	0.023	0.031	0.039	0.047	0.055	0.063
DIA. OF HEAD	0.125	0.198	0.250	0.313	0.375	0.438	0.500

Rivets are ordered by the last two figures of the part number denoting the length in $\frac{1}{16}$ " and the remaining figure or figures denoting the diameter in $\frac{1}{32}$ ", e.g. the part reference for a $\frac{1}{8}$ " dia. Rivet $\frac{1}{2}$ " long would be AS 469/408.

AS 483

PARALLEL SHEAR BUSH

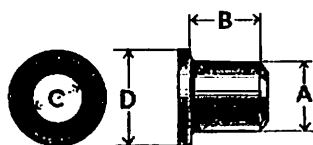

Material:
STAINLESS STEEL
(SELF-FINISH)

ITEM	'A' DIAM. — 0.001" — 0.002" IN.	'B' IN.	'C' DIAM. IN.	'D' IN.
G2	$\frac{5}{16}$ (0.3125)	0.25	$\frac{1}{16}$ (0.1875)	$\frac{1}{2}$
G4	$\frac{5}{16}$ (0.3125)	0.50	$\frac{1}{16}$ (0.1875)	$\frac{1}{2}$
J2	$\frac{3}{8}$ (0.375)	0.25	$\frac{1}{4}$ (0.25)	$\frac{3}{16}$
J4	$\frac{3}{8}$ (0.375)	0.50	$\frac{1}{4}$ (0.25)	$\frac{3}{16}$
L2	$\frac{7}{16}$ (0.4375)	0.25	$\frac{5}{16}$ (0.3125)	$\frac{1}{2}$
L4	$\frac{7}{16}$ (0.4375)	0.50	$\frac{5}{16}$ (0.3125)	$\frac{1}{2}$
L6	$\frac{7}{16}$ (0.4375)	0.75	$\frac{5}{16}$ (0.3125)	$\frac{1}{2}$
N3	$\frac{1}{2}$ (0.5)	0.38	$\frac{3}{8}$ (0.375)	$\frac{1}{2}$
N5	$\frac{1}{2}$ (0.5)	0.63	$\frac{3}{8}$ (0.375)	$\frac{1}{2}$
N7	$\frac{1}{2}$ (0.5)	0.88	$\frac{3}{8}$ (0.375)	$\frac{1}{2}$

Brown Brothers Engineering Ltd

AS 484

TAPER SHEAR BUSH

ITEM	'A'		'B'	DRILL 'C'	'D'	'E'
	IN.					
J	$\frac{3}{8}$ (0.375)	— 0.0005 — 0.003	0.63	No. 13 (0.185)	$\frac{1}{2}$	$\frac{7}{16}$ (0.4375)
JA	$\frac{3}{8}$ (0.375)	— 0.0005 — 0.003	0.38	No. 13 (0.185)	$\frac{1}{2}$	$\frac{7}{16}$ (0.4375)
L	$\frac{7}{16}$ (0.4375)	— 0.0005 — 0.004	0.63	No. 13 (0.185)	$\frac{9}{16}$	$\frac{1}{2}$ (5)
LA	$\frac{7}{16}$ (0.4375)	— 0.0005 — 0.004	0.38	No. 13 (0.185)	$\frac{9}{16}$	$\frac{1}{2}$ (5)
N	$\frac{1}{2}$ (0.5)	— 0.0005 — 0.004	0.75	No. 13 (0.185)	$\frac{5}{8}$	$\frac{9}{16}$ (0.5625)
NA	$\frac{1}{2}$ (0.5)	— 0.0005 — 0.004	0.38	No. 13 (0.185)	$\frac{5}{8}$	$\frac{9}{16}$ (0.5625)
P	$\frac{9}{16}$ (0.5625)	— 0.001 — 0.005	0.75	No. 13 (0.185)	$\frac{11}{16}$	$\frac{5}{8}$ (0.625)
PA	$\frac{9}{16}$ (0.5625)	— 0.001 — 0.005	0.5	No. 13 (0.185)	$\frac{11}{16}$	$\frac{5}{8}$ (0.625)
Q	$\frac{5}{8}$ (0.625)	— 0.001 — 0.005	0.75	No. 13 (0.185)	$\frac{3}{4}$	$\frac{11}{16}$ (0.6875)
QA	$\frac{5}{8}$ (0.625)	— 0.001 — 0.005	0.5	No. 13 (0.185)	$\frac{3}{4}$	$\frac{11}{16}$ (0.6875)
S	$\frac{3}{4}$ (0.75)	— 0.001 — 0.005	0.88	No. 13 (0.185)	$\frac{7}{8}$	$\frac{13}{16}$ (0.8125)
SA	$\frac{3}{4}$ (0.75)	— 0.001 — 0.005	0.5	No. 13 (0.185)	$\frac{7}{8}$	$\frac{13}{16}$ (0.8125)
U	$\frac{7}{8}$ (0.875)	— 0.001 — 0.005	0.88	$\frac{1}{4}$	1	$\frac{15}{16}$ (0.9375)
W	1 (1.00)	— 0.001 — 0.005	1.00	$\frac{1}{4}$	$1\frac{1}{8}$	$1\frac{1}{16}$ (1.0625)

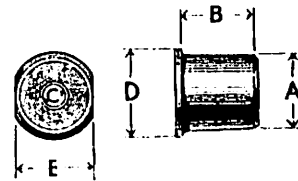

Material :
STAINLESS STEEL
(SELF-FINISH)

AS 491, 492 & 493 CLIPS

PART No.	W	SIZE OF HOLES	S.W.G.
AS 491	IN. 0.50	No. 25	20
AS 492	0.63	No. 10	20
AS 493	0.75	No. 10	18



Material : ALUMINIUM (ANODISED)

Clips are ordered by the part number followed by a number indicating the length "L," in $\frac{1}{16}$ "', e.g. a clip 0.5" wide with length "L," of 2.5" would be AS 491/25.

Brown Brothers Engineering Ltd

AS 1151 SINGLE BALL BEARING SHROUDED PULLEY

See page 184

AS 1152 DOUBLE BALL BEARING SHROUDED PULLEY

See page 184

AS 1153 TRIPLE BALL BEARING SHROUDED PULLEY

See page 184

AS 1154 QUADRUPLE BALL BEARING SHROUDED PULLEY

See page 184

AS 1242, 2920 & 4563

90° COUNTERSUNK HEAD BOLTS—SLOTTED

Material : **AS 1242** HIGH TENSILE STEEL (CADMIUM)
AS 2920 STAINLESS STEEL (SELF)
AS 4563 ALUMINIUM ALLOY (ANODISED & DYED BLUE)

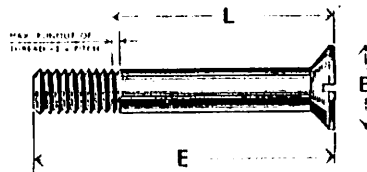

ITEM	THREAD SIZE	B DIA.		E MIN.	RANGE OF L PLAIN LENGTHS	
		MIN.	MAX.		MIN.	MAX.
B	4 BA	IN. 0.242	IN. 0.252	IN. L + 0.40	IN. 0.1	IN. 5.3
C	2 BA	0.314	0.326	L + 0.45	0.1	5.3
E	1/4" BSF	0.427	0.442	L + 0.50	0.2	5.4
G	3/16" BSF	0.535	0.553	L + 0.55	0.2	5.4
J	3/8" BSF	0.641	0.664	L + 0.65	0.2	5.4
L	7/16" BSF	0.748	0.774	L + 0.70	0.2	5.4
N	1/2" BSF	0.855	0.885	L + 0.80	0.3	5.4

METHOD OF ORDERING

Bolts are ordered by the drawing number, followed by a numeral(s) representing the plain length "L," in tenths of an inch, followed by the item letter for the size of thread required, e.g. the complete part number for a 1/4" BSF 90° countersunk head bolt in high tensile steel with a plain length of 1.6" would be AS 1242--16E.

A bolt with "L" length 0.05" should be called up as 1/2" not 0.05", e.g. as 1212 1/2C, and will be threaded up to the head.

Brown Brothers Engineering Ltd

AS 1244, 2921 & 4564

RAISED 90° COUNTERSUNK HEAD BOLTS—SLOTTED

Material: AS 1244 HIGH TENSILE STEEL (CADMIUM)
AS 2921 STAINLESS STEEL (SELF)
AS 4564 ALUMINIUM ALLOY (ANODISED & DYED BLUE)

ITEM	THREAD SIZE	B DIA.	E MIN.	RANGE OF L PLAIN LENGTHS	
				MIN.	MAX.
B	4 BA	IN. 0.25	IN. L + 0.10	IN. 0.1	IN. 5.3
C	2 BA	0.32	L + 0.45	0.1	5.3
E	1" BSF	0.41	L + 0.50	0.2	5.4
G	3/8" BSF	0.55	L + 0.55	0.2	5.4
J	1" BSF	0.66	L + 0.65	0.2	5.4
L	3/2" BSF	0.76	L + 0.70	0.2	5.4
N	1" BSF	0.88	L + 0.80	0.3	5.4

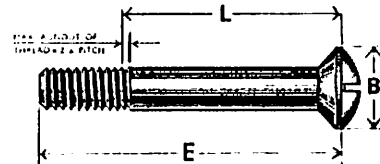

METHOD OF ORDERING

Bolts are ordered by the drawing number, followed by a numeral(s) representing the plain length "L" in tenths of an inch, followed by the item letter for the size of thread required, e.g. the complete part number for a 1/4" BSF raised countersunk 90° head bolt with a plain length of 1.6" would be AS 1244-16E.

A bolt with "L" length 0.05" should be called up to as 1/2" not 0.05", e.g. AS 1244 1/2C, and will be threaded up to the head.

AS 1246, 2922 & 4565

ROUND HEAD BOLTS—SLOTTED

Material: AS 1246 HIGH TENSILE STEEL (CADMIUM)
AS 2922 STAINLESS STEEL (SELF)
AS 4565 ALUMINIUM ALLOY (ANODISED & DYED BLUE)

ITEM	THREAD	B DIA.	E MIN.	RANGE OF L PLAIN LENGTHS	
				MIN.	MAX.
B	4 BA	IN. 0.25	IN. L + 0.40	IN. 0.05	IN. 5.3
C	2 BA	0.32	L + 0.45	0.05	5.3
E	1" BSF	0.41	L + 0.50	0.05	5.4

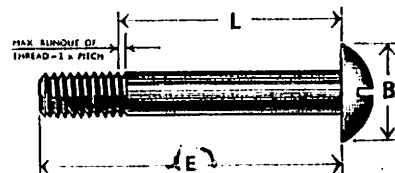

METHOD OF ORDERING

Bolts are ordered by the drawing number, followed by a numeral(s) representing the plain length "L" in tenths of an inch, followed by the item letter for the size of thread required, e.g. the complete part number for a 1/4" BSF round-head bolt in high tensile steel with a plain length of 1.6" would be AS 1246-16E.

A bolt with a plain length "L" of 0.05" should be called up as 1/2" not 0.05", e.g. AS1246 1/2C.

Brown Brothers Engineering Ltd

AS 1248, 2923 & 4566 MUSHROOM HEAD BOLTS—SLOTTED

Material: AS 1248 HIGH TENSILE STEEL (CADMIUM)
 AS 2923 STAINLESS STEEL (SELF)
 AS 4566 ALUMINIUM ALLOY
 (ANODISED & DYED BLUE)

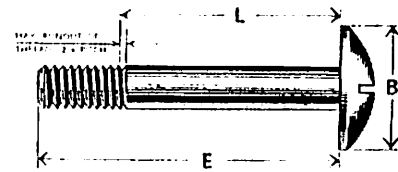

ITEM	THREAD SIZE	B DIA.	E MIN.	RANGE OF L PLAIN LENGTHS	
				MIN.	MAX.
B	4 BA	IN. 0.375	IN. L ± 0.40	IN. 0.05	IN. 5.3
C	2 BA	0.4375	L ± 0.45	0.05	5.3
E	1/4" BSF	0.625	L ± 0.50	0.05	5.4
G	5/16" BSF	0.75	L ± 0.55	0.05	5.4

METHOD OF ORDERING

Bolts are ordered by the drawing number, followed by a numeral(s) representing the plain length "L" in tenths of an inch, followed by the item letter for the size of thread required, e.g. the complete part number for a 1/4" BSF mushroom-head bolt in high tensile steel with a plain length of 1.6" would be AS 1248-16E.

A Bolt with an "L" length of 0.05" should be called up as 1/2" not 0.05", e.g. AS 1248-1/2C.

AS 1327 & 1328 4 BA CONNECTOR

Material: STEEL (CADMIUM)

4 BA. Thread

THREAD	
AS 1327	Right hand
AS 1328	Left hand

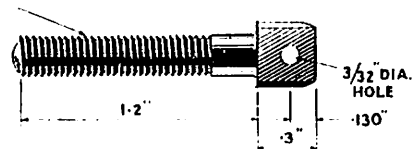

AS 1860 to 1864 CABLE TYPE PLAIN BEARING PULLEYS

Material: PULLEY, Plastic Moulding

BUSH, Steel (SELF-FINISH)

PART No.	STEEL BUSH	ALTERNATIVE TO SBAC BALL BEARING PULLEY	CABLE SIZE CWT.	A	X	Y
AS 1860	AS 1865	AS 111	5	IN. 1.5	IN. 0.3125	IN. 0.25
AS 1861	AS 1866	AS 103	5 & 10	2.0	0.5	0.375
AS 1862	AS 1866	AS 104	10, 15 & 20	3.0	0.5	0.375
AS 1863	AS 1867	AS 105	20, 25 & 35	4.0	0.625	0.5
AS 1864	AS 1867	AS 106	20, 25 & 35	5.0	0.625	0.5

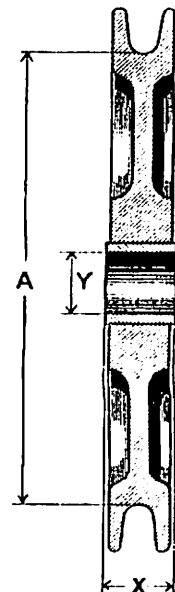

Brown Brothers Engineering Ltd

ASI876 to 1879 HINGES WITH SINGLE FLANGE PLATES

Material: ALUMINIUM ALLOY

PART No.	PLATE THICKNESS	WIDTH OPEN
AS 1876	20 S.W.G.	IN. 0.75
AS 1877	20 S.W.G.	1.0
AS 1878	18 S.W.G.	1.25
AS 1879	18 S.W.G.	1.50

METHOD OF ORDERING

Hinges are ordered by the part number, followed by the overall length required in inches and decimal of an inch. The overall length must be a multiple of 0.50" and the maximum length available is 72".

ASI880 & 1881 HINGES WITH DOUBLE FLANGE PLATES

Material: ALUMINIUM ALLOY

PART No.	PLATE THICKNESS	WIDTH OPEN
AS 1880	20 S.W.G.	IN. 1.5
AS 1881	20 S.W.G.	2.0

METHOD OF ORDERING

Hinges are ordered by the part number, followed by the overall length given in inches and fraction of an inch. The overall length must be a multiple of 1/4" and the maximum length available is 71 1/4".

AS 1900

CABLE CLIPS

Material: ALUMINIUM (SELF)

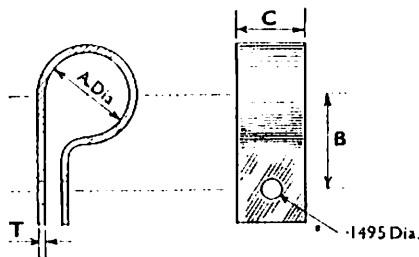

ITEM No.	A	B	C	T
A	IN. 0.20	IN. 0.38	IN. 0.38	20 S.W.G.
B	0.25	0.41	0.38	20 S.W.G.
C	0.32	0.44	0.38	20 S.W.G.
D	0.38	0.47	0.38	20 S.W.G.
E	0.44	0.50	0.50	20 S.W.G.
F	0.50	0.56	0.50	20 S.W.G.
G	0.62	0.62	0.50	20 S.W.G.
H	0.75	0.68	0.50	18 S.W.G.
J	0.88	0.75	0.50	18 S.W.G.
K	1.0	0.81	0.50	18 S.W.G.

AS 1901

CABLE CLIPS

Material: ALUMINIUM (SELF)

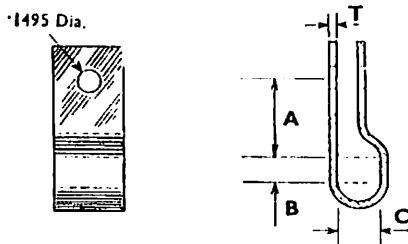

ITEM No.	A	B	C	D	T
A	IN. 0.40	IN. 0.09	IN. 0.15	IN. 0.38	20 S.W.G.
B	0.41	0.10	0.18	0.38	20 S.W.G.
C	0.43	0.09	0.22	0.38	20 S.W.G.
D	0.45	0.12	0.25	0.38	20 S.W.G.
E	0.52	0.23	0.37	0.50	18 S.W.G.
F	0.59	0.42	0.50	0.50	18 S.W.G.

Brown Brothers Engineering Ltd

SADDLE WASHERS

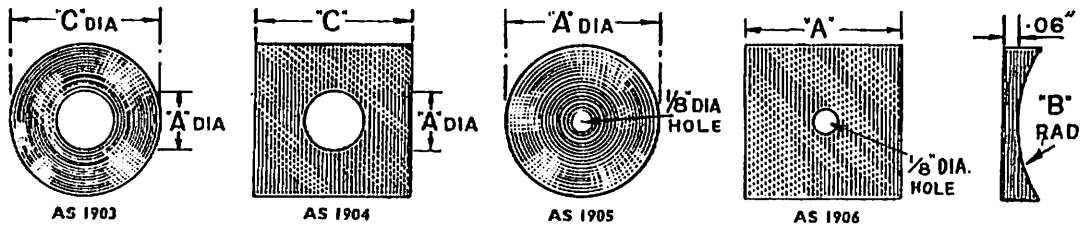

AS 1903

AS 1904

AS 1905

AS 1906

Material: ALUM. ALLOY (Anodised)				Material: ALUM. ALLOY (Anodised)				Material: MILD STEEL (Cadmium)			Material: MILD STEEL (Cadmium)		
ITEM	A Dia.	B Rad.	C Dia.	ITEM	A Dia.	B Rad.	C Dia.	ITEM	A Dia.	B Rad.	ITEM	A	B Rad.
C6	1/8	1/8	1/8	C6	1/8	1/8	1/8	C6	1/8	1/8	C6	1/8	1/8
C7	0-1/16	1/8	1/8	C7	0-1/16	1/8	1/8	C7	1/16	1/8	C7	1/16	1/8
C8	0-1/16	1/8	1/8	C8	0-1/16	1/8	1/8	C8	1/16	1/8	C8	1/16	1/8
C9	0-1/16	1/8	1/8	C9	0-1/16	1/8	1/8	C9	1/16	1/8	C9	1/16	1/8
C10	0-1/16	1/8	1/8	C10	0-1/16	1/8	1/8	C10	1/16	1/8	C10	1/16	1/8
C11	0-1/16	1/8	1/8	C11	0-1/16	1/8	1/8	C11	1/16	1/8	C11	1/16	1/8
C12	0-1/16	1/8	1/8	C12	0-1/16	1/8	1/8	C12	1/16	1/8	C12	1/16	1/8
C13	0-1/16	1/8	1/8	C13	0-1/16	1/8	1/8	C13	1/16	1/8	C13	1/16	1/8
C14	0-1/16	1/8	1/8	C14	0-1/16	1/8	1/8	C14	1/16	1/8	C14	1/16	1/8
E7	1/8	1/8	1/8	E7	1/8	1/8	1/8	E7	1/8	1/8	E7	1/8	1/8
E8	1/8	1/8	1/8	E8	1/8	1/8	1/8	E8	1/8	1/8	E8	1/8	1/8
E9	1/8	1/8	1/8	E9	1/8	1/8	1/8	E9	1/8	1/8	E9	1/8	1/8
E10	1/8	1/8	1/8	E10	1/8	1/8	1/8	E10	1/8	1/8	E10	1/8	1/8
E11	1/8	1/8	1/8	E11	1/8	1/8	1/8	E11	1/8	1/8	E11	1/8	1/8
E12	1/8	1/8	1/8	E12	1/8	1/8	1/8	E12	1/8	1/8	E12	1/8	1/8
E13	1/8	1/8	1/8	E13	1/8	1/8	1/8	E13	1/8	1/8	E13	1/8	1/8
E14	1/8	1/8	1/8	E14	1/8	1/8	1/8	E14	1/8	1/8	E14	1/8	1/8
E15	1/8	1/8	1/8	E15	1/8	1/8	1/8	E15	1/8	1/8	E15	1/8	1/8
E16	1/8	1/8	1/8	E16	1/8	1/8	1/8	E16	1/8	1/8	E16	1/8	1/8
G8	1/8	1/8	1/8	G8	1/8	1/8	1/8	G8	1/8	1/8	G8	1/8	1/8
G9	1/8	1/8	1/8	G9	1/8	1/8	1/8	G9	1/8	1/8	G9	1/8	1/8
G10	1/8	1/8	1/8	G10	1/8	1/8	1/8	G10	1/8	1/8	G10	1/8	1/8
G11	1/8	1/8	1/8	G11	1/8	1/8	1/8	G11	1/8	1/8	G11	1/8	1/8
G12	1/8	1/8	1/8	G12	1/8	1/8	1/8	G12	1/8	1/8	G12	1/8	1/8
G13	1/8	1/8	1/8	G13	1/8	1/8	1/8	G13	1/8	1/8	G13	1/8	1/8
G14	1/8	1/8	1/8	G14	1/8	1/8	1/8	G14	1/8	1/8	G14	1/8	1/8
G15	1/8	1/8	1/8	G15	1/8	1/8	1/8	G15	1/8	1/8	G15	1/8	1/8
G16	1/8	1/8	1/8	G16	1/8	1/8	1/8	G16	1/8	1/8	G16	1/8	1/8
J8	1/8	1/8	1/8	J8	1/8	1/8	1/8	J8	1/8	1/8	J8	1/8	1/8
J9	1/8	1/8	1/8	J9	1/8	1/8	1/8	J9	1/8	1/8	J9	1/8	1/8
J10	1/8	1/8	1/8	J10	1/8	1/8	1/8	J10	1/8	1/8	J10	1/8	1/8
J11	1/8	1/8	1/8	J11	1/8	1/8	1/8	J11	1/8	1/8	J11	1/8	1/8
J12	1/8	1/8	1/8	J12	1/8	1/8	1/8	J12	1/8	1/8	J12	1/8	1/8
J13	1/8	1/8	1/8	J13	1/8	1/8	1/8	J13	1/8	1/8	J13	1/8	1/8
J14	1/8	1/8	1/8	J14	1/8	1/8	1/8	J14	1/8	1/8	J14	1/8	1/8
J15	1/8	1/8	1/8	J15	1/8	1/8	1/8	J15	1/8	1/8	J15	1/8	1/8
J16	1/8	1/8	1/8	J16	1/8	1/8	1/8	J16	1/8	1/8	J16	1/8	1/8

METHOD OF ORDERING

Quote the Part No. followed by the Item No. of the required Washer. Example: A Saddle Washer for a 1/4" B.S.F. Bolt to fit on to a 1 1/2" Dia. Tube would be AS 1903. E12.

Brown Brothers Engineering Ltd

AS 2160 to 2168

HAND NUTS

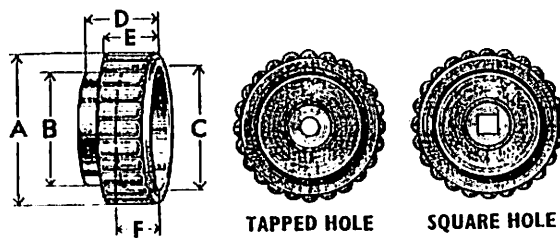

Material : PLASTIC MOULDING
INSERT--BRASS OR STEEL
(SELF-FINISH)

PART NO.	DIMENSIONS						INSERT	
	A	B	C	D	E	F	TAPPED	Sq. BROACHED HOLE
AS 2100	IN. 1.0	IN. 0.7	IN. 0.8	IN. 0.5	IN. 0.37	IN. 0.25	4 BA	IN. —
AS 2101	1.0	0.7	0.8	0.5	0.37	0.25	2 BA	—
AS 2102	1.0	0.7	0.8	0.5	0.37	0.25	—	0.15
AS 2163	1.37	0.7	1.12	0.7	0.5	0.37	1" B.S.F.	—
AS 2164	1.37	0.7	1.12	0.7	0.5	0.37	—	0.2
AS 2165	1.75	0.87	1.5	0.8	0.6	0.45	1.1/2" B.S.F.	—
AS 2166	1.75	0.87	1.5	0.8	0.6	0.45	1" B.S.F.	—
AS 2167	1.75	0.87	1.5	0.8	0.6	0.45	—	0.25
AS 2168	1.41	0.56	1.12	0.5	0.38	0.22	1/2" B.S.F.	—

AS 2227 SOLID RIVETS—SNAP HEAD

See page 185

AS 2228 SOLID RIVETS—MUSHROOM HEAD

See page 185

AS 2229 SOLID RIVETS—90° COUNTERSUNK HEAD

See page 185

AS 2230 SOLID RIVETS—120° COUNTERSUNK HEAD

See page 186

Brown Brothers Engineering Ltd

AS 2294

SPRING CLIP

Note: Two Fixing Holes provided for items 10 to 13

Material: SPRING STEEL (CADMIUM)

ITEM	1	2	3	4	5	6	7	8	9	10	11	12	13
To Grip Dia.	$\frac{1}{4}$ "	$\frac{1}{2}$ "	$\frac{3}{4}$ "	$1\frac{1}{4}$ "	$1\frac{1}{2}$ "	1"	$1\frac{1}{8}$ "	$1\frac{1}{4}$ "	$1\frac{1}{2}$ "	$1\frac{3}{4}$ "	$2\frac{1}{4}$ "	$2\frac{1}{2}$ "	2"

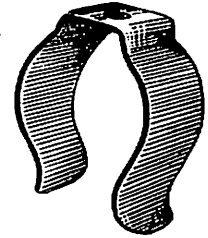

AS 2295

SPRING CLIP

Material: SPRING STEEL (CADMIUM)

ITEM	1	2	3	4	5	6	7	8	9		11
To Grip Dia.	$\frac{1}{4}$ "	$\frac{1}{2}$ "	$\frac{3}{4}$ "	$1\frac{1}{4}$ "	$1\frac{1}{2}$ "	1"	$1\frac{1}{8}$ "	$1\frac{1}{4}$ "	$1\frac{1}{2}$ "		2"

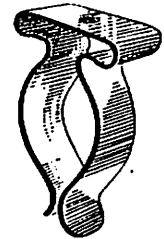

AS 2296

SPRING CLIP (HEAVY GAUGE)

Material: SPRING STEEL (CADMIUM)

ITEM	5	6	8	9	10	12
To Grip Dia.	$\frac{1}{2}$ "	$\frac{3}{4}$ "	1"	$1\frac{1}{8}$ "	$1\frac{1}{4}$ "	$1\frac{1}{2}$ "

Otherwise identical to AS 2295

AS 2297 to 2303. AS 2304 to 2310 DISTANCE TUBES

A.S. Drawing No. is obtained from table and the length is indicated by a stroke No. to the nearest .01 of an inch. Use prefix "0" for lengths below 1.0".



Example:—

A $\frac{5}{16}$ " O/Dia. Distance Tube .75" long is
AS 2300/075

Example:—

A $\frac{1}{2}$ " O/Dia. Distance Tube 1.65" long is
AS 2310/165

AS 2297 to 2303

Material: MILD STEEL (CADMIUM)

PART No.	O/Dia. D
AS 2297	$\frac{5}{16}$ " 22 S.W.G.
AS 2298	$\frac{7}{16}$ " 22 S.W.G.
AS 2299	$\frac{1}{2}$ " 22 S.W.G.
AS 2300	$\frac{5}{8}$ " 18 S.W.G.
AS 2301	$\frac{3}{4}$ " 18 S.W.G.
AS 2302	$\frac{7}{8}$ " 18 S.W.G.
AS 2303	$1\frac{1}{8}$ " 18 S.W.G.

AS 2304 to 2310

**Material: ALUMINIUM ALLOY
(SELF-FINISH)**

PART No.	O/Dia. D
AS 2304	$\frac{5}{16}$ " 22 S.W.G.
AS 2305	$\frac{7}{16}$ " 22 S.W.G.
AS 2306	$\frac{1}{2}$ " 22 S.W.G.
AS 2307	$\frac{5}{8}$ " 18 S.W.G.
AS 2308	$\frac{3}{4}$ " 18 S.W.G.
AS 2309	$\frac{7}{8}$ " 18 S.W.G.
AS 2310	$1\frac{1}{8}$ " 18 S.W.G.

Brown Brothers Engineering Ltd

AS 2311

ROTATING KNOB

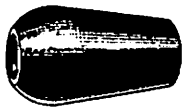

Material : PLASTIC

Size 1.19" long

In BLACK, RED, GREEN or BLUE.

AS 2312

SCREW (FOR ROTATING KNOB AS 2311)

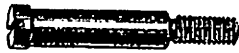

Material : STEEL (CADMIUM)

Size 2 BA x 1.7" long

AS 2313

ROTATING KNOB



Material : PLASTIC

Size 1.91" long

AS 2314 SCREW (FOR ROTATING KNOB AS 2313)

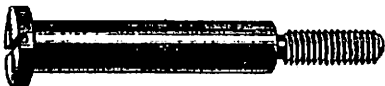

Material : STEEL (CADMIUM)

Size 1/4" BSF x 2.7" long

AS 2370

COPPER BONDING LEAD

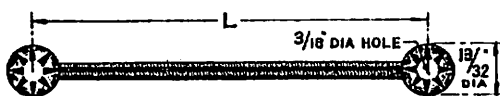

ITEM	L
	IN.
A	3.0
B	4.5
C	6.0

Brown Brothers Engineering Ltd

AS 2381 to 2383

TENSION RODS

Material : HIGH TENSILE STEEL (CADMIUM)

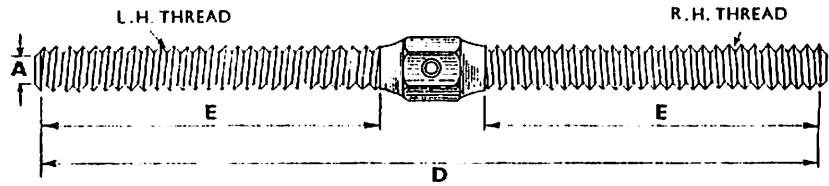

PART No.	A THREAD	A/F		D	E
		MIN.	MAX.		
AS 2381	$\frac{1}{4}$ " BSF	IN. 0.321	IN. 0.324	IN. 4.12	IN. 1.75
AS 2382	$\frac{5}{16}$ " BSF	0.440	0.445	5.10	2.12
AS 2383	$\frac{3}{8}$ " BSF	0.440	0.445	5.88	2.50

AS 2384 to 2392

TRUNNION

Material: HIGH TENSILE STEEL (CADMIUM)

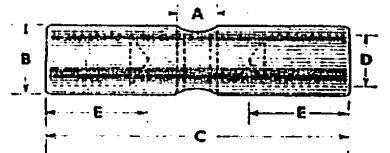

PART No.	A THREAD	B DIA.	C	D DIA.	E
AS 2384	$\frac{1}{4}$ " BSF R.H.	IN. 0.44	IN. 1.50	IN. 0.312	IN. 0.44
AS 2385	$\frac{5}{16}$ " BSF R.H.	0.57	2.50	0.375	0.80
AS 2386	$\frac{3}{8}$ " BSF R.H.	0.69	3.00	0.500	1.00
AS 2387	$\frac{1}{4}$ " BSF L.H.	0.44	1.50	0.312	0.44
AS 2388	$\frac{5}{16}$ " BSF L.H.	0.57	2.50	0.375	0.80
AS 2389	$\frac{3}{8}$ " BSF L.H.	0.69	3.00	0.500	1.00
AS 2390	Drill F—0.257" dia.	0.44	1.50	0.312	0.44
AS 2391	Drill P—0.323" dia.	0.57	2.50	0.375	0.80
AS 2392	Drill W—0.386" dia.	0.69	3.00	0.500	1.00

AS 2393 to 2395

COLLAR

Material : ALUMINIUM ALLOY (ANODISED)

PART No.	A DIA.	B DIA.	C	E DIA.
AS 2393	IN. 0.62	$\frac{3}{16}$ "	IN. 0.40	IN. 0.266
AS 2394	0.75	$\frac{3}{16}$ "	0.65	0.332
AS 2395	0.87	$\frac{3}{16}$ "	0.79	0.397

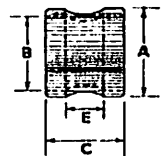

Brown Brothers Engineering Ltd

AS 2398 & 2510 FILLER CAPS (Hinged 2" and 2½")

(WHITWORTH THREADS)

For Flush Type Filler Caps, see AS 2590, AS 4749 & AS 4750

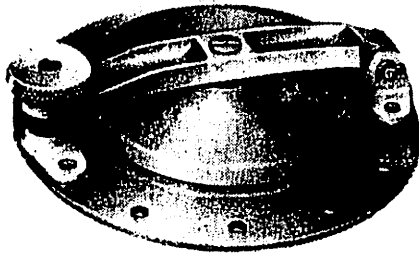

PART No.	DIA. OF ORIFICE	FIXING
AS 2398	IN. 2.5	12 Holes 0.1935" dia. on 4.125" P.C.D.
AS 2510	2.0	10 Holes 0.1935" dia. on 3.6" P.C.D.

AS 2434 to 2438, 2444, 2445 QUICK RELEASE PINS (With ring)

AS 2439 TO 2443 QUICK RELEASE PINS (Less ring)

Material : MILD STEEL (CADMIUM)

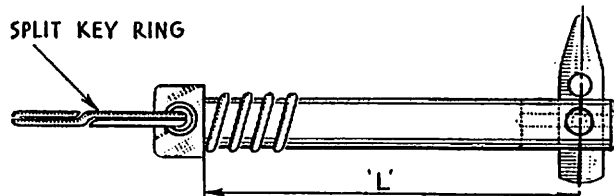

To find length "L" for pin diameters of ¼" to ½" incl. add 0.6" to length of work that pin is required to fit and for pin diameters ⅝" and ¾" add 0.7" to length of work that pin is required to fit.

PART No.		PIN DIA.	SPLIT KEY RING INTERNAL DIA.
WITH RING	LESS RING		
AS 2434	AS 2439	IN. ¼	IN. 1
AS 2435	AS 2440	⅝	1½
AS 2436	AS 2441	¾	1½
AS 2437	AS 2442	7/16	1½
AS 2438	AS 2443	½	1½
AS 2444	—	¾	2
AS 2445	—	¾	2

METHOD OF ORDERING

Quick release pins are ordered by the part number followed by a number representing length "L" in 1/10 of an inch, e.g. a ¾" dia. pin with calculated length "L" of 1.0" + 0.60" would be AS 2436/16 or a ¾" dia. pin with calculated length "L" of 1.20" + 0.70" would be AS 2444/19.

Brown Brothers Engineering Ltd

AS 2504

CLOSE TOLERANCE BOLTS

Material: HIGH TENSILE STEEL (HEAD & THREAD—CADMIUM;
PLAIN SHANK & UNDERSIDE OF HEAD—SELF-TEMPORARY RUST PREVENTATIVE)
See also A30.

ITEM	THREAD SIZE	ACROSS FLATS		SHANK DIA.		MIN. THREAD LENGTH
		MIN.	MAX.	MIN.	MAX.	
C	2 BA	IN. 0.245	IN. 0.248	IN. 0.18005	IN. 0.18955	IN. 0.40
E	$\frac{1}{4}$ " BSF	0.321	0.324	0.24925	0.24975	0.45
G	$\frac{5}{16}$ " BSF	0.440	0.445	0.31175	0.31225	0.50
J	$\frac{3}{8}$ " BSF	0.520	0.525	0.37425	0.37475	0.60

METHOD OF ORDERING

Bolts are ordered by the drawing number followed by a numeral(s) representing the plain length in tenths of an inch, followed by the item letter for the size of thread required. The complete part number for a $\frac{5}{16}$ " BSF bolt with a plain length of 1.6" would be AS2501/16G.

AS 2505

STUD

Material: PLASTIC MOULDING

AS 2506

FLEXIBLE STRIP

Material: P.V.C.

AS 2510

FILLER CAP

(See page 197)

AS 2573

DRAIN VALVE— $1\frac{1}{4}$ "

ITEM	DESCRIPTION	PART NO.	No. OFF
1	Valve	AS 2579	1
2	Valve Guide	AS 403	1
4	Spring	AS 404	1
5	Body	AS 2574	1
6	Cap Assembly	AS 2588	1
7	Joint Washer	AS 410	1
9	Seating Ring	AS 2578	1

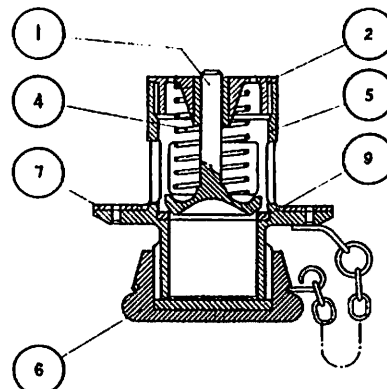

Brown Brothers Engineering Ltd

AS 2590 FILLER CAP (Flush—2½")

WHITWORTH THREADS

ITEM	COMPRISING	PART No.
1	Base	AS 2591
2	Sealing Ring	AS 5364
3	Cap	AS 2592

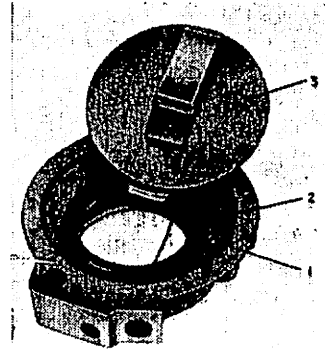

AS 2806 to 2808. AS 2809 to 2811

STEEL (Cadmium)

(ALUM. ALLOY ANODISED)

SEAMLESS DISTANCE TUBES

METHOD OF ORDERING

Seamless Distance Tubes are ordered by the part number followed by a number representing the outside diameter in $\frac{1}{8}$ of an inch, followed by the length required to the nearest 0.01 of an inch, e.g. a $\frac{7}{16}$ " O/dia. Distance Tube in 20 S.W.G. by 0.75" long would be AS 2807/7/075.
N.B.: Use prefix "0" for lengths below 1 inch.

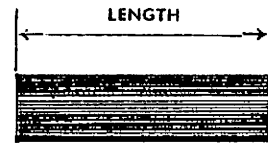

GAUGE	
PART NOS.	S.W.G.
AS 2806 and AS 2809	22
AS 2807 and AS 2810	20
AS 2808 and AS 2811	17

AS 2902 & 2903 ¼" BALL END

Material: STEEL (SELF-FINISH)

PART No.	CABLE SPEC.	
	CONSTR.	STRENGTH
AS 2902	4 × 7	3 cwt.
AS 2903	7 × 7	5 cwt.

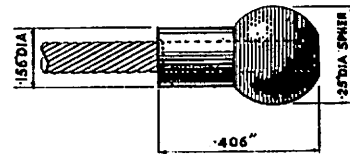

AFTER SWAGING

AS 2904 & 2905 ¼" BALL END

Material: STEEL (SELF-FINISH)

PART No.	CABLE SPEC.		BREAKING LOAD OF END
	CONSTR.	STRENGTH	
AS 2904	4 × 7	3 cwt.	268 lbs.
AS 2905	7 × 7	5 cwt.	448 lbs.

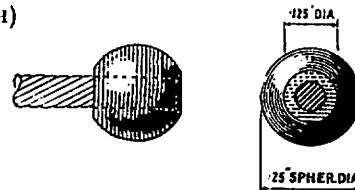

AFTER SWAGING

Brown Brothers Engineering Ltd

**AS 2918 & 3362 SOLID RIVETS—90° COUNTERSUNK HEAD
(Close Tolerance)**

**Material : AS 2918 ALUMINIUM ALLOY—L37 (SELF)
AS 3362 ALUMINIUM ALLOY—L86 (ANODISED & DYED VIOLET)**

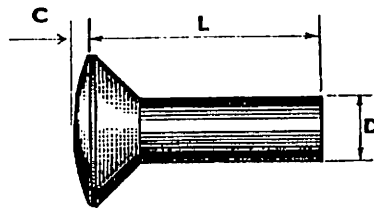

DIA. D. ± 0.001"	$\frac{3}{16}$ "	$\frac{1}{4}$ "	$\frac{5}{16}$ "	$\frac{3}{8}$ "	$\frac{7}{16}$ "	$\frac{1}{2}$ "	$\frac{5}{8}$ "	$\frac{3}{4}$ "
	IN.	IN.	IN.	IN.	IN.	IN.	IN.	IN.
Depth of head ± 0.0015"	0.035	0.046	0.058	0.070	0.082	0.094	0.106	0.118
Dia. of head ± 0.001"	0.157	0.212	0.267	0.322	0.377	0.432	0.487	0.542
$C_{-0}^{+0.003}$	0.003	0.003	0.003	0.004	0.004	0.005	0.005	0.006

METHOD OF ORDERING

Rivets are ordered by the last two figures of the part number denoting the length in $\frac{1}{16}$ " and the remaining figure or figures denoting the dia. in $\frac{1}{32}$ ", e.g. the part reference for a $\frac{1}{8}$ " dia. rivet $\frac{1}{2}$ " long in L37 would be AS 2918/408.

**AS 2919 & 3363 SOLID RIVETS—120° COUNTERSUNK HEAD
(Close Tolerance)**

**Material : AS 2919 ALUMINIUM ALLOY—L37 (SELF)
AS 3363 ALUMINIUM ALLOY—L86 (ANODISED & DYED VIOLET)**

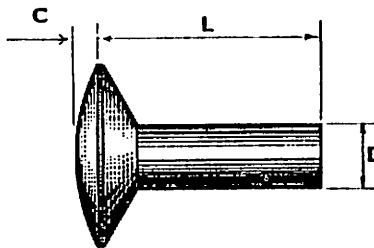

DIA. D. ± 0.001"	$\frac{3}{16}$ "	$\frac{1}{4}$ "	$\frac{5}{16}$ "	$\frac{3}{8}$ "	$\frac{7}{16}$ "	$\frac{1}{2}$ "	$\frac{5}{8}$ "	$\frac{3}{4}$ "
	IN.	IN.	IN.	IN.	IN.	IN.	IN.	IN.
Depth of head ± 0.0015"	0.027	0.036	0.045	0.054	0.063	0.072	0.081	0.090
Dia. of head ± 0.001"	0.177	0.230	0.302	0.364	0.426	0.489	0.552	0.614
$C_{-0}^{+0.003}$	0.003	0.003	0.003	0.004	0.004	0.005	0.005	0.006

METHOD OF ORDERING

Rivets are ordered by the last two figures of the part number denoting the length in $\frac{1}{16}$ " and the remaining figure or figures denoting the dia. in $\frac{1}{32}$ ", e.g. the part reference for a $\frac{1}{8}$ " dia. rivet $\frac{1}{2}$ " long in L37 would be AS 2919/408.

Brown Brothers Engineering Ltd

AS 2920 90° COUNTERSUNK HEAD BOLTS

See page 188

AS 2921 RAISED 90° COUNTERSUNK HEAD BOLTS

See page 189

AS 2922 ROUND HEAD BOLTS

See page 189

AS 2923 MUSHROOM HEAD BOLTS

See page 190

AS 3031 to 3036 PACKING WASHERS

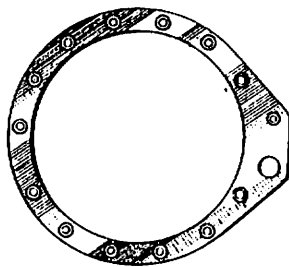

For use with Filler Cap AS 2590

Material : ALUMINIUM ALLOY (ANODISED)

PART No.	S.W.G.	REQD. FOR
AS 3031	22	12 G. Skin
AS 3032	18	14 G. Skin
AS 3033	16	16 G. Skin
AS 3034	14	18 G. Skin
AS 3035	14	20 G. Skin
AS 3036	12	22 G. Skin

Brown Brothers Engineering Ltd

AS 3119

SHEAR BUSHES—PARALLEL

Material :

STAINLESS STEEL

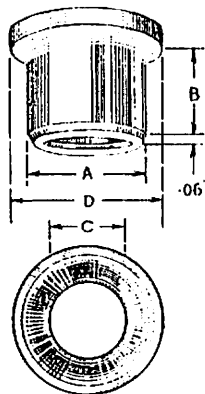

ITEM	A DIA. NEWALL "P" - 0.00025" - 0.00075"	B	C DIA.	D
G2	IN. $\frac{5}{16}$	IN. 0.25	IN. $\frac{3}{8}$	IN. $\frac{1}{8}$
G4	$\frac{7}{16}$	0.50	$\frac{1}{2}$	$\frac{1}{8}$
J2	$\frac{1}{2}$	0.25	$\frac{3}{8}$	$\frac{1}{16}$
J4	$\frac{1}{2}$	0.50	$\frac{3}{8}$	$\frac{1}{16}$
L2	$\frac{3}{4}$	0.25	$\frac{3}{8}$	$\frac{1}{8}$
L4	$\frac{3}{4}$	0.50	$\frac{3}{8}$	$\frac{1}{8}$
L6	$\frac{7}{8}$	0.75	$\frac{3}{8}$	$\frac{1}{8}$
N3	$\frac{1}{2}$	0.39	$\frac{1}{2}$	$\frac{1}{16}$
N5	$\frac{3}{4}$	0.63	$\frac{1}{2}$	$\frac{1}{16}$
N7	$\frac{1}{2}$	0.88	$\frac{1}{2}$	$\frac{1}{16}$

The figures denote the length of the shear bush in $\frac{1}{8}$ in.

AS 3180

"P" CLIPS—RUBBER COVERED

Material : ALUMINIUM (SELF-FINISH)

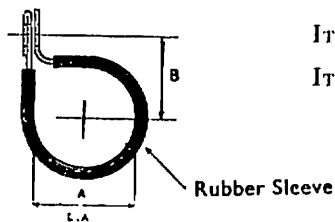

ITEMS 3-11 : 22 S.W.G.

ITEMS 12-20 : 20 S.W.G.

ITEM No.	3	4	5	6	7	8	9	10	11	12	13	14	15	16	18	20	
DIA. A.	$\frac{1}{16}$ "	$\frac{1}{8}$ "	$\frac{3}{16}$ "	$\frac{1}{4}$ "	$\frac{5}{16}$ "	$\frac{3}{8}$ "	$\frac{7}{16}$ "	$\frac{1}{2}$ "	$\frac{9}{16}$ "	$\frac{5}{8}$ "	$\frac{11}{16}$ "	$\frac{3}{4}$ "	$\frac{13}{16}$ "	$\frac{7}{8}$ "	1"	$1\frac{1}{8}$ "	$1\frac{1}{4}$ "
B. IN.	0.34	0.375	0.40	0.43	0.46	0.55	0.58	0.61	0.64	0.70	0.73	0.75	0.79	0.82	0.88	0.94	

METHOD OF ORDERING

Clips are ordered by the item number followed by a symbol letter indicating the size of fixing hole, e.g. a $\frac{1}{2}$ " internal diameter clip having a fixing hole suitable for a 2 BA bolt would be AS 3180/8C.

Drill No. 24 for 4 BA bolt or No. 6 UNC Symbol B

Drill 0.1935" dia. for 2 BA bolt or No. 10 UNF Symbol C

Clips of $\frac{1}{2}$ " dia. and over can be drilled to suit $\frac{1}{4}$ " BSF bolts (drill letter "F") Symbol E.

Brown Brothers Engineering Ltd

AS 3181

"P" CLIPS

ITEM	A	B	MATERIAL S.W.G.
3	IN. 2	IN. 0.32	22
4	1	0.35	22
5	1.5	0.38	22
6	2	0.41	22
7	2.5	0.44	22
8	3	0.53	22
9	3.5	0.56	22
10	4	0.60	22
11	4.5	0.63	22
12	5	0.67	20
13	5.5	0.70	20
14	6	0.73	20
15	6.5	0.76	20
16	7	0.79	20
18	8	0.85	20
20	9	0.91	20
24	11	1.05	18
28	14	1.18	18
32	2	1.3	18

Material :

ALUMINIUM ALLOY (SELF)

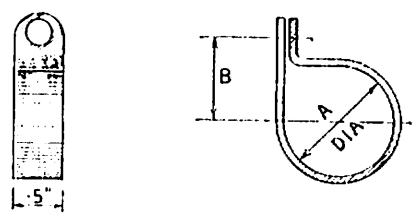

METHOD OF ORDERING

Clips are ordered by the item number followed by a symbol letter indicating the size of fixing hole, e.g. a 1/2" internal diameter clip having a fixing hole suitable for a 2 BA bolt would be AS 3181/8C.

Drill 0.152" Dia. for 4 BA bolt or No. 6 UNC Symbol B

Drill 0.1935" dia. for 2 BA bolt or No. 10 UNF Symbol C

Clips of 1/2" dia. and over can be drilled to suit 1/4" bolts (drill 0.257" Dia.) Symbol E

AS 3281 to 3284

ATTACHMENT PIN

Material: BERYLLIUM COPPER (SELF)

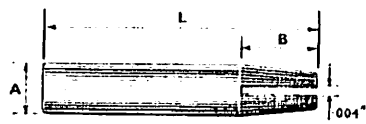

AS No.	A Dia.	B	L
AS 3281	IN. 0.0409	IN. 0.065	IN. 0.255
	0.0405		0.250
AS 3282	0.0644	0.105	0.405
	0.0640		0.400
AS 3283	0.0944	0.140	0.535
	0.0940		0.530
AS 3284	0.0944	0.170	0.655
	0.0940		0.650

Brown Brothers Engineering Ltd

AS 3294 90° COUNTERSUNK RECESS HEAD BOLTS

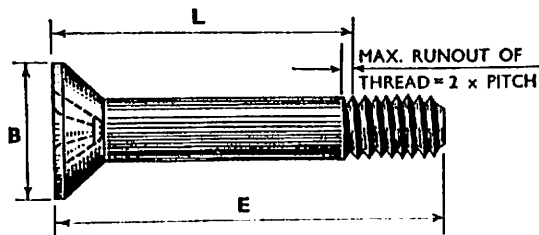

Material: HIGH TENSILE STEEL
(CADMIUM)

ITEM	THREAD SIZE	B DIA.		E MIN.	RANGE OF L, PLAIN LENGTHS	
		MIN.	MAX.		MIN.	MAX.
B	4 BA	IN. 0.236	IN. 0.252	IN. L + 0.40	IN. 0.1	IN. 1.6
C	2 BA	0.306	0.324	L + 0.45	0.2	2.1
E	1/4" BSP	0.419	0.440	L + 0.50	0.2	2.3
G	5/16" BSP	0.542	0.566	L + 0.55	0.3	2.2
J	3/4" BSP	0.621	0.648	L + 0.65	0.3	2.1

METHOD OF ORDERING

Bolts are ordered by the drawing number, followed by a numeral(s) representing the plain length "L" in tenths of an inch, followed by the item letter for the size of thread required, e.g. the complete part number for a 1/4" BSP 90° countersunk head bolt, with a plain length of 1.6", would be AS 3294/16E.

AS 3295 RAISED 90° COUNTERSUNK RECESS HEAD BOLTS

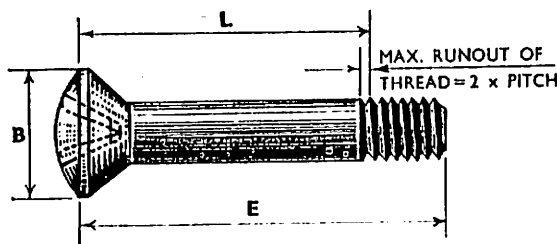

Material: HIGH TENSILE STEEL
(CADMIUM)

ITEM	THREAD SIZE	B DIA.		E MIN.	RANGE OF PLAIN LENGTHS L	
		MIN.	MAX.		MIN.	MAX.
B	4 BA	IN. 0.236	IN. 0.252	IN. L + 0.40	IN. 0.1	IN. 1.6
C	2 BA	0.306	0.324	L + 0.45	0.2	2.1
E	1/4" BSP	0.419	0.440	L + 0.50	0.2	2.3
G	5/16" BSP	0.542	0.566	L + 0.55	0.3	2.2
J	3/4" BSP	0.621	0.648	L + 0.65	0.3	2.1

METHOD OF ORDERING

Bolts are ordered by the drawing number, followed by a numeral(s) representing the plain length "L" in tenths of an inch, followed by the item letter for the size of thread required, e.g. the complete part number for a 1/4" BSP raised 90° countersunk head bolt, with a plain length of 1.6", would be AS 3295/16E.

Brown Brothers Engineering Ltd

AS 3296 RAISED 120° COUNTERSUNK RECESS HEAD BOLTS

**Material: HIGH TENSILE STEEL
(CADMIUM)**

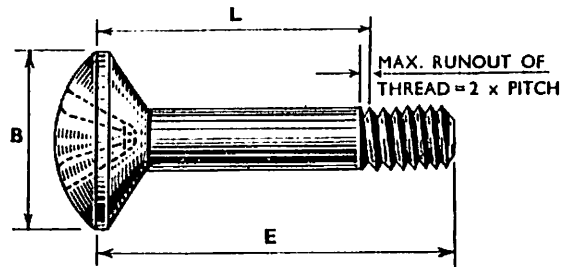

ITEM	THREAD SIZE	B DIA.		E MIN.	RANGE OF PLAIN LENGTHS L.	
		MIN.	MAX.		MIN.	MAX.
B	4 BA	IN. 0.268	IN. 0.284	IN. L + 0.40	IN. 0.1	IN. 1.6
C	2 BA	0.352	0.370	L + 0.45	0.1	2.1
E	1/4" BSF	0.479	0.500	L + 0.50	0.2	2.3
G	5/8" BSF	0.601	0.625	L + 0.55	0.2	2.3
J	1" BSF	0.723	0.750	L + 0.65	0.3	2.1

METHOD OF ORDERING

Bolts are ordered by the drawing number, followed by a numeral(s) representing the plain length "L" in tenths of an inch, followed by the item letter for the size of thread required, e.g. the complete part number for a 1/4" BSF raised 120° countersunk head bolt, with a plain length of 1.6", would be AS 3296/16E.

AS 3297 120° COUNTERSUNK RECESS HEAD BOLTS

**Material: HIGH TENSILE STEEL
(CADMIUM)**

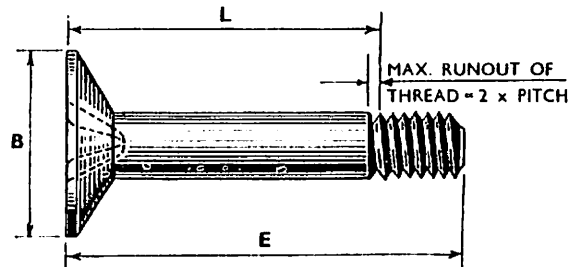

ITEM	THREAD SIZE	B DIA.		E MIN.	RANGE OF PLAIN LENGTHS L.	
		MIN.	MAX.		MIN.	MAX.
C	2 BA	IN. 0.352	IN. 0.370	IN. L + 0.15	IN. 0.1	IN. 2.1
E	1/4" BSF	0.479	0.500	L + 0.50	0.2	2.3
G	5/8" BSF	0.601	0.625	L + 0.55	0.2	2.2
J	1" BSF	0.723	0.750	L + 0.65	0.3	2.1

METHOD OF ORDERING

Bolts are ordered by the drawing number, followed by a numeral(s) representing the plain length "L" in tenths of an inch, followed by the item letter for the size of thread required, e.g. the complete part number for a 1/4" BSF 120° countersunk head bolt with a plain length of 1.6" would be AS 3297/16E.

Brown Brothers Engineering Ltd

AS 3360

FLEXIBLE BONDING

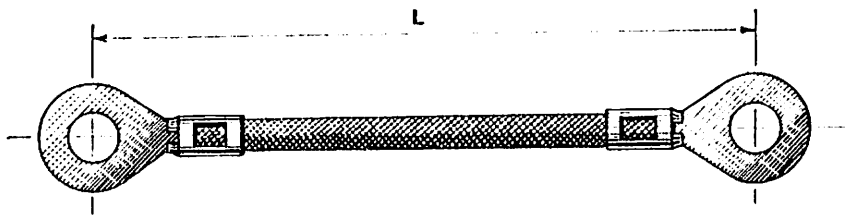

CODE	ITEM To Suit BOLT SIZE
B	4 BA or No. 6 × 32 UNC
C	2 BA or No. 10 × 32 UNF
E	¼" BSF or ¼" UNF
G	⅝" BSF or ⅝" UNF
J	⅜" BSF or ⅜" UNF

METHOD OF ORDERING

Length "L" in 1" increments, minimum length 3". A 4" flexible bonding with 4BA ends is AS 3360/B4B;
 A 4" flexible bonding with 4BA or No. 6 × 32 UNC end and ¼" BSF or ¼" UNF end is AS 3360/B4E.
 The smaller end must always be quoted first.

AS 3362

SOLID RIVETS (90° Csk. Head)

(CLOSE TOLERANCE)

See page 200

AS 3363

SOLID RIVETS (120° Csk. Head)

(CLOSE TOLERANCE)

See page 200

AS 3365 & 3366

FILLER CAPS (Flush Types)

(WHITWORTH THREADS)

Replaced by AS 4641 and AS 4642

AS 4525 & 5418, AS 4526 & 5419 SUPPORT CLIPS

ALLUM. ALLOY
(SELF)

STEEL
(CADMIUM)

(RUBBER
COVERED)

AS 4525 & 4526 With Earthing Tongue

AS 5418 & 5419 Without Earthing Tongue

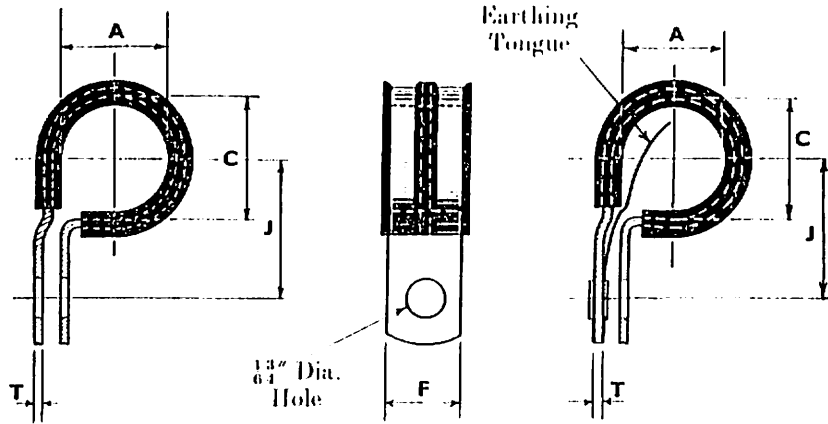

ITEM	A DIA.	C DIA.	F	J	T	S.W.G.
3	3/8"	18.	18.	18.		22
4	1/2"	0.40	0.38	0.53		22
5	5/8"	0.46	0.38	0.56		22
6	1"	0.53	0.38	0.59		22
7	1 1/8"	0.59	0.38	0.62		22
8	1 1/4"	0.65	0.38	0.65		22
9	1 3/8"	0.71	0.50	0.74		20
10	1 1/2"	0.78	0.50	0.77		20
11	1 5/8"	0.84	0.50	0.80		20
12	1 3/4"	0.90	0.50	0.84		20
13	1 7/8"	0.96	0.50	0.87		20
14	2"	1.03	0.50	0.90		20
15	1 1/2"	1.09	0.50	0.93		20
16	1 1/4"	1.15	0.50	0.97		18
17	1 3/8"	1.21	0.50	1.00		18
18	1 1/2"	1.28	0.50	1.01		18
19	1 5/8"	1.34	0.50	1.07		18
20	1 3/4"	1.40	0.50	1.10		18
22	1 7/8"	1.53	0.50	1.16		18
24	2"	1.65	0.50	1.22		18
26	2 1/8"	1.78	0.50	1.34		18
28	2 1/4"	1.90	0.50	1.40		18
30	2 3/8"	2.03	0.50	1.46		18
32	2 1/2"	2.15	0.50	1.52		18
34	2 7/8"	2.28	0.50	1.59		18

Brown Brothers Engineering Ltd

AS 4561

WIRE LOCKING TABS

Material: 20 S.W.G. STAINLESS STEEL (SELF)

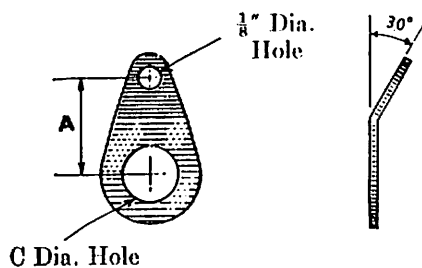

ITEM	SIZE	A BEFORE BENDING	C
1	4 BA	IN. 0.35	IN. 0.152
2	2 BA	0.40	0.197
	No. 10 UNF		
3	1"	0.45	0.265
4	3/8"	0.50	0.328
5	1"	0.55	0.390
6	3/8"	0.60	0.453

AS 4562

PRECISION WASHERS

Material: STEEL (CADMIUM)

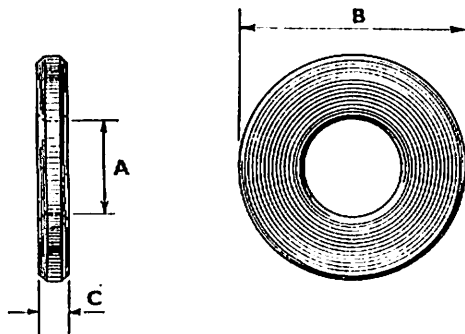

ITEM	TO SUIT NOM. THREAD	A DIA.	B DIA.	C
E	1"	IN. 0.259	IN. 0.625	IN. 0.07
G	3/8"	0.322	0.750	0.08
J	1"	0.385	0.876	0.09
L	3/8"	0.452	1.000	0.10
N	1"	0.515	1.125	0.11
P	3/8"	0.577	1.250	0.12
Q	1"	0.640	1.376	0.13

The locking faces of these washers are machined to be parallel within 0.002" and to give 100% circular and 75% (Min.) radial contact with surface plate.

AS 4563 90° COUNTERSUNK HEAD BOLTS (Slotted)

See page 188

AS 4564 RAISED 90° COUNTERSUNK HEAD BOLTS (Slotted)

See page 189

Brown Brothers Engineering Ltd

AS 4565 ROUND HEAD BOLTS (Slotted)

See page 189

AS 4566 MUSHROOM HEAD BOLTS (Slotted)

See page 190

AS 4569 2BA HEXAGON BOLTS (Close Tolerance Shank)

Material: HIGH TENSILE STEEL (CADMIUM)

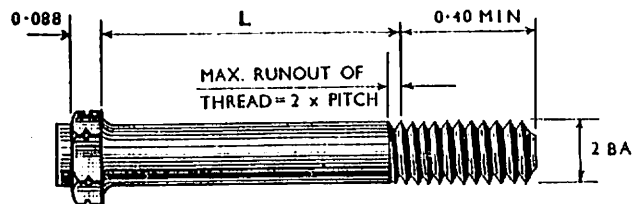

ACROSS FLATS		SHANK DIA. AFTER PLATING	
MIN.	MAX.	MIN.	MAX.
IN. 0.215	IN. 0.248	IN. 0.18905	IN. 0.18955

METHOD OF ORDERING

Bolts are ordered by the drawing number, followed by a numeral(s) representing the plain length "L" required in tenths of an inch, e.g. the complete part number for a bolt with a plain length of 1.6" would be AS 4569/16.

AS 4580

CLIP

Material: NYLASTIC

Details on application

AS 4581

CLIP WITH EARTHING TONGUE

Material: NYLASTIC

Details on application

Brown Brothers Engineering Ltd

AS 4589

BALLAST WEIGHT

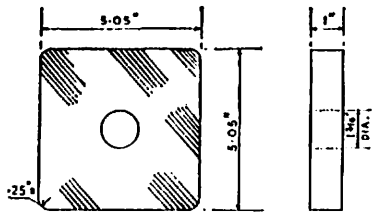

Replacing AGS 650.

Material: LEAD

Weight: 10 lb.

For 17.5 lb. Ballast Weight, see AS 4590 below

AS 4590

BALLAST WEIGHT

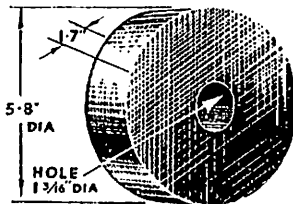

Replacing AGS 670.

Material: LEAD

Approx. Weight: 17.5 lb.

For 10 lb. Ballast Weight, see AS 4589 above

AS 4597

ROUNDHEAD RECESS HEAD BOLTS

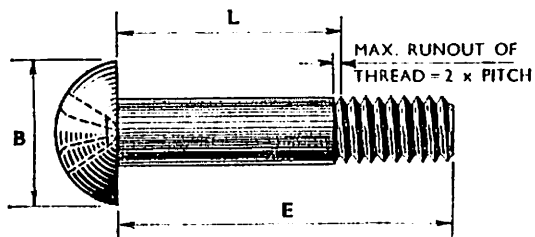

**Material: HIGH TENSILE STEEL
(CADMIUM)**

ITEM	THREAD SIZE	B DIA.		E MIN.	RANGE OF PLAIN LENGTHS L	
		MIN.	MAX.		MIN.	MAX.
B	4 BA	IN. 0.252	IN. 0.268	L + 0.40"	IN. 0.1	IN. 1.6
C	2 BA	0.332	0.350	L + 0.45"	0.1	2.1
E	1/4" BSF	0.451	0.472	L + 0.50"	0.1	2.3
G	5/16" BSF	0.507	0.591	L + 0.55"	0.1	2.2
J	3/8" BSF	0.681	0.708	L + 0.65"	0.1	2.1

METHOD OF ORDERING

Bolts are ordered by the drawing number, followed by a numeral(s) representing the plain length "L" in tenths of an inch, followed by the item letter for the size of thread required, e.g. the complete part number for a 1/4" BSF round head bolt, with a plain length of 1.6", would be AS 4597/16E.

Brown Brothers Engineering Ltd

AS 4598

MUSHROOM RECESS HEAD BOLTS

Material: HIGH TENSILE STEEL (CADMIUM)

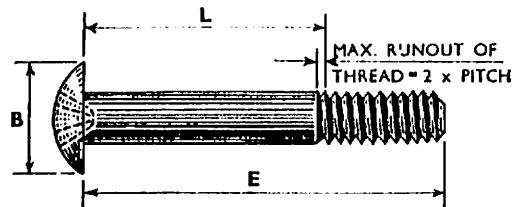

ITEM	THREAD SIZE	B DIA.		E MIN.	RANGE OF PLAIN LENGTHS L	
		MIN.	MAX.		MIN.	MAX.
B	4 BA	IN. 0.305	IN. 0.321	$L + 0.40''$	IN. 0.1	IN. 1.6
C	2 BA	0.398	0.416	$L + 0.45''$	0.1	2.1
E	$\frac{1}{4}''$ BSF	0.547	0.668	$L + 0.50''$	0.1	2.3
G	$\frac{5}{16}''$ BSF	0.689	0.893	$L + 0.55''$	0.1	2.2
J	$\frac{3}{8}''$ BSF	0.791	0.818	$L + 0.65''$	0.1	2.1

METHOD OF ORDERING

Bolts are ordered by the drawing number, followed by a numeral(s) representing the plain length "L" in tenths of an inch, followed by the item letter for the size of thread required, e.g. the complete part number for A $\frac{1}{4}''$ BSF mushroom head bolt, with a plain length of 1.6", would be AS 4598/16E.

AS 4641 & 4642
(WHITWORTH THREADS)

FILLER CAPS (Flush Types)

Replaced by AS 6541 and AS 6542

Brown Brothers Engineering Ltd

AS 4645 & 4646 SOLID RIVETS 90° CSK. HEAD (Oversize Shank)

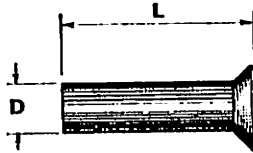

PART No.	MATERIAL	MIN. ULT. TENSILE STRENGTH TONS PER SQ. IN.	SPECIFICATION	FINISH	IDENTIFICATION
AS 4645	Aluminium Alloy	17	L 86	Anodic	Violet
AS 4646	Aluminium Alloy	25	L 37	Anodic	Plain

NOM. DIA.	SHANK DIA. D		DEPTH OF HEAD	DIA. OF HEAD
	MIN.	MAX.		
$\frac{7}{84}$ "	IN. 0.108	IN. 0.112	IN. 0.030	IN. 0.164
$\frac{9}{84}$ "	0.140	0.144	0.042	0.219
$\frac{11}{84}$ "	0.171	0.175	0.054	0.273
$\frac{13}{84}$ "	0.202	0.206	0.066	0.328

NOM. DIA.	LENGTH L							
	$\frac{1}{8}$ "	$\frac{3}{16}$ "	$\frac{1}{2}$ "	$\frac{5}{8}$ "	$\frac{3}{4}$ "	$\frac{7}{8}$ "	1 "	$1\frac{1}{8}$ "
$\frac{7}{84}$ "	302	303	304	305	306	307	308	316
$\frac{9}{84}$ "	402	403	404	405	406	407	408	416
$\frac{11}{84}$ "	502	503	504	505	506	507	508	516
$\frac{13}{84}$ "	602	603	604	605	606	607	608	616

METHOD OF ORDERING

A $\frac{9}{84}$ " Dia. rivet in L86, with a plain length of $\frac{1}{2}$ ", is ordered as AS 4645/408.

Brown Brothers Engineering Ltd

AS 4647 & 4648

SOLID RIVETS 120° CSK. HEAD (Oversize Shank)

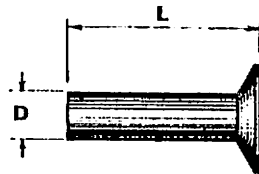

PART No.	MATERIAL	MIN. U.L.F. TENSILE STRENGTH TONS. PER. SQ IN.	SPECIFICATION	FINISH	IDENTIFICATION
AS 4647	Aluminium Alloy	17	L 86	Anodic	Violet
AS 4648	Aluminium Alloy	25	L 37	Anodic	Plain

NOM. DIA.	SHANK DIA. D		DEPTH OF HEAD	DIA. OF HEAD
	MIN.	MAX.		
$\frac{7}{32}$ "	IN. 0.108	IN. 0.112	IN. 0.028	IN. 0.187
$\frac{9}{32}$ "	0.140	0.144	0.037	0.250
$\frac{11}{32}$ "	0.171	0.175	0.048	0.312
$\frac{13}{32}$ "	0.202	0.206	0.055	0.375

NOM. DIA.	LENGTH L							
	$\frac{1}{8}$ "	$\frac{1}{4}$ "	1"	$\frac{1}{2}$ "	$\frac{3}{8}$ "	$\frac{7}{16}$ "	$\frac{1}{2}$ "	1"
$\frac{7}{32}$ "	302	303	304	305	306	307	308	316
$\frac{9}{32}$ "	402	403	404	405	406	407	408	416
$\frac{11}{32}$ "	502	503	504	505	506	507	508	516
$\frac{13}{32}$ "	602	603	604	605	606	607	608	616

METHOD OF ORDERING

A $\frac{9}{32}$ " dia. rivet in L86, with a plain length of $\frac{1}{2}$ ", is ordered as AS 4647/408.

Brown Brothers Engineering Ltd

AS 4676 to 4693 **CLIPS (Bushed)**
Material: NYLASTIC
 Details on application

AS 4694 **SOLID RIVETS (Snap Head)**
 See page 185

AS 4695 **SOLID RIVETS (90° Csk. Head)**
 See page 185

AS 4696 **SOLID RIVETS (120° Csk. Head)**
 See page 186

AS 4716 **SOLID RIVETS (100° Csk. Head)**
Material: 5% M/G ALUM. ALLOY (ANODISED)
 J.58

AS 4749 & 4750 **FILLER CAPS (Flush Types)**
 (WHITWORTH THREADS)

Replacing AS 6541 and AS 6542

ITEM	COMPRISING	PART NUMBERS	
		AS 4749 WITH VENT	AS 4750 WITHOUT VENT
1	Base	AS 6320	AS 6321
2	Cap	AS 4751	
3	Sealing Ring	AS 5304	

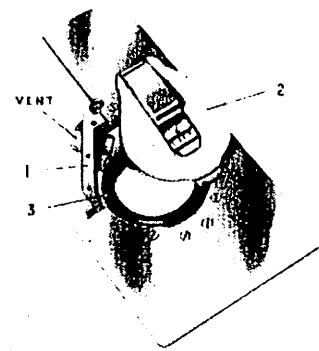

Brown Brothers Engineering Ltd

AS 5364

FILLER CAP SEALING RING

Used on Filler Caps AS 2590 AS 3365 AS 3366 AS 6318 AS 6319 AS 6541 AS 6542
AS 4611 AS 4642 AS 4749 AS 4750 AS 6742 AS 6743

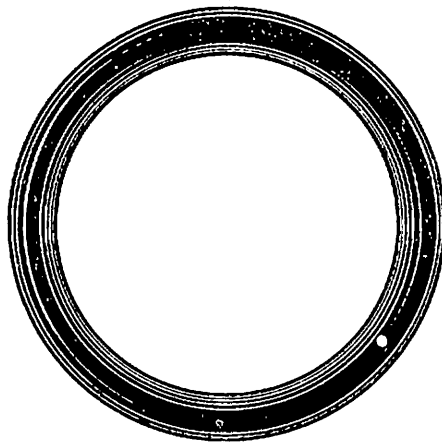
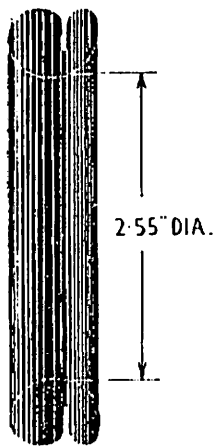

Material :
RUBBER MOULDING
DTD 560. Grade "C"
Quality "Q"

AS 5401 to 5415

SEALING RINGS

Material:
IMPREGNATED ASBESTOS
(GRAPHITED)

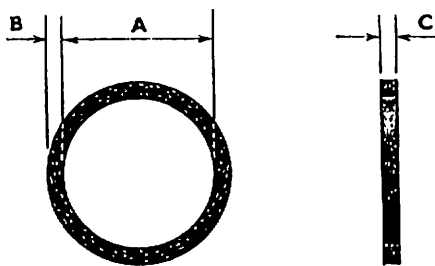

PART No.	A DIA.	B	C
	IN.	IN.	IN.
AS 5401	1.15	0.130	0.105
AS 5402	1.65	0.130	0.105
AS 5403	2.15	0.130	0.105
AS 5404	2.65	0.130	0.105
AS 5405	2.90	0.130	0.105
AS 5406	3.10	0.155	0.155
AS 5407	3.60	0.155	0.155
AS 5408	4.10	0.155	0.155
AS 5409	4.30	0.155	0.155
AS 5410	4.60	0.155	0.155
AS 5411	5.10	0.155	0.155
AS 5412	5.60	0.155	0.155
AS 5413	6.10	0.155	0.155
AS 5414	6.60	0.155	0.155
AS 5415	7.10	0.155	0.155

AS 5418 & 5419 SUPPORT CLIPS (Rubber Covered)

ALLUM. ALLOY (SELF) STEEL (CADMIUM)

See AS 4525 and AS 4526

Brown Brothers Engineering Ltd

AS 5440 to 5457 GROOVED COUPLING FLANGE

AS 5459 to 5476 PLAIN COUPLING FLANGE

Material: ALUM. ALLOY
(SELF-FINISH)

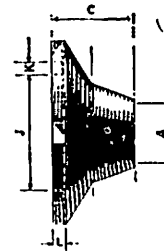
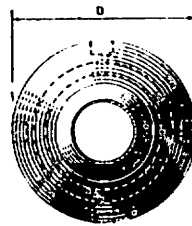

PART NO.		FLANGE			SEAL GROOVE		
GROOVED COUPLING	PLAIN COUPLING	"A" DIA.	"R" DIA.	"C" DIA.	"J" DIA.	K	L
AS 5440	AS 5459	0.9"	1.75"	0.7"	1.15"	0.125" 0.135"	0.070" 0.080"
AS 5441	AS 5400	1.15"	2.25"	0.7"	1.65"	0.125" 0.135"	0.070" 0.080"
AS 5442	AS 5481	1.40"	2.25"	0.7"	1.65"	0.125" 0.135"	0.070" 0.080"
AS 5443	AS 5482	1.65"	2.75"	0.7"	2.15"	0.125" 0.135"	0.070" 0.080"
AS 5444	AS 5483	1.90"	2.75"	0.7"	2.15"	0.125" 0.135"	0.070" 0.080"
AS 5445	AS 5484	2.15"	3.25"	0.7"	2.65"	0.125" 0.135"	0.070" 0.080"
AS 5446	AS 5485	2.40"	3.25"	0.7"	2.65"	0.125" 0.135"	0.070" 0.080"
AS 5447	AS 5486	2.65"	3.50"	0.7"	2.90"	0.125" 0.135"	0.070" 0.080"
AS 5448	AS 5487	2.90"	4.00"	0.8"	3.10"	0.150" 0.160"	0.120" 0.130"
AS 5449	AS 5488	3.40"	4.50"	0.8"	3.60"	0.150" 0.160"	0.120" 0.130"
AS 5450	AS 5489	3.90"	5.00"	0.8"	4.10"	0.150" 0.160"	0.120" 0.130"
AS 5451	AS 5470	4.10"	5.20"	0.8"	4.30"	0.150" 0.160"	0.120" 0.130"
AS 5452	AS 5471	4.40"	5.50"	0.8"	4.60"	0.150" 0.160"	0.120" 0.130"
AS 5453	AS 5472	4.90"	6.00"	0.8"	5.10"	0.150" 0.160"	0.120" 0.130"
AS 5454	AS 5473	5.40"	6.50"	0.8"	5.60"	0.150" 0.160"	0.120" 0.130"
AS 5455	AS 5474	5.90"	6.90"	0.8"	6.10"	0.150" 0.160"	0.120" 0.130"
AS 5456	AS 5475	6.40"	7.50"	0.8"	6.60"	0.150" 0.160"	0.120" 0.130"
AS 5457	AS 5476	6.90"	7.90"	0.8"	7.10"	0.150" 0.160"	0.120" 0.130"

Brown Brothers Engineering Ltd

AS 6210 to 6212

TENSION RODS

Replaced by B.S. SP118

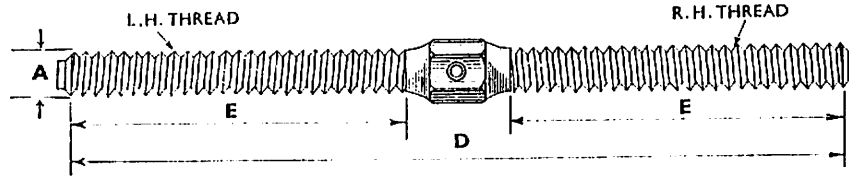

Material: HIGH TENSILE STEEL (CADMIUM)

PART No.	A THREAD	A/E		D	E
		MIN.	MAX.		
AS 6210	1/4" UNF	IN. 0.319	IN. 0.324	IN. 4.12	IN. 1.75
AS 6211	5/16" UNF	0.4305	0.4375	5.10	2.12
AS 6212	3/8" UNF	0.4305	0.4375	5.88	2.50

AS 6213 to 6218

TRUNNION

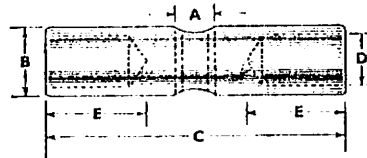

Material: HIGH TENSILE STEEL (CADMIUM)

PART No.	A THREAD	B DIA.	C	D DIA.	E
AS 6213	1/2" UNF RH	IN. 0.44	IN. 1.50	IN. 0.312	IN. 0.44
AS 6214	5/16" UNF RH	0.57	2.50	0.375	0.80
AS 6215	3/8" UNF RH	0.69	3.00	0.500	1.00
AS 6216	1/2" UNF LH	0.44	1.50	0.312	0.44
AS 6217	5/16" UNF LH	0.57	2.50	0.375	0.80
AS 6218	3/8" UNF LH	0.69	3.00	0.500	1.00

AS 6241, 6609 & 6610 HAND NUTS

Material: PLASTIC MOULDING (INSERT—BRASS OR STEEL)

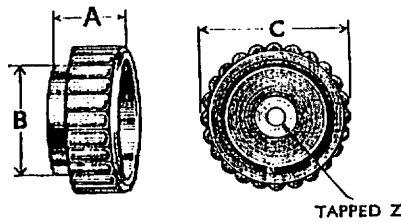

PART No.	Z THREAD	A	B DIA.	C DIA.
AS 6241	1/2" UNF	IN. 0.7	IN. 0.7	IN. 1.37
AS 6609	No. 6-32 UNC	0.5	0.7	1.0
AS 6610	No. 10-32 UNF	0.5	0.7	1.0

Brown Brothers Engineering Ltd

AS 6316 & 6317 WIRE THREAD INSERTS

For UNF Threads For UNC Threads

Material: SPRING STEEL (SELF) Details on application.

AS 6318 & 6319 FILLER CAP (Flush Type)

(WHITWORTH THREADS)

Replaced by AS 6541 and AS 6542.

AS 6322 ASSEMBLY OF BONDING SOCKET

AS 6323 ASSEMBLY OF HOUSING AND BONDING SOCKET

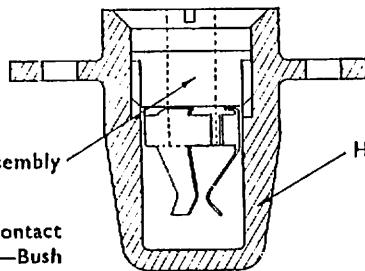

AS 6322 Assembly Housing AS 6326

Comprising: AS 6324—Contact and AS 6325—Bush

AS 6327 & 6328 WIRE THREAD INSERTS

For UNF Threads For UNC Threads

AS 6327 replaced by AS 6733

AS 6328 replaced by AS 6734

AS 6348 & 6357 FILLER CAPS (2" & 2½")

(UNIFIED THREADS)

For Flush Type see AS 6742 and AS 6743

PART NO.	DIA. OF ORIFICE	FIXING
AS 6348	IN. 2.5	12 holes 0.1935" dia. on 4.125" P.C.D.
AS 6357	2.0	10 holes 0.1935" dia. on 3.60" P.C.D.

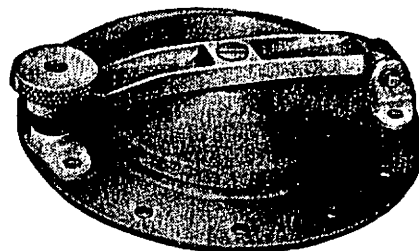

Brown Brothers Engineering Ltd

AS 6398 SCREW FOR ROTATING KNOB

Material: STEEL (CADMIUM)



Size: No. 10-32 UNF × 1.7" long

AS 6399 SCREW FOR ROTATING KNOB

Material: STEEL (CADMIUM)

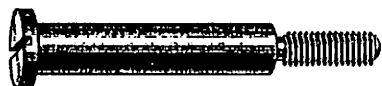

Size: $\frac{1}{4}$ " UNF × 2.7" long

AS 6541 & 6542 FILLER CAPS (Flush Type)
(WHITWORTH THREAD)

Replaced by AS 4749 and AS 4750

AS 6609 & 6610 HAND NUTS

See AS 6241

AS 6687 $\frac{3}{8}$ " UNF OUTER SLEEVE

Material: ALUMINIUM ALLOY (ANODISED)

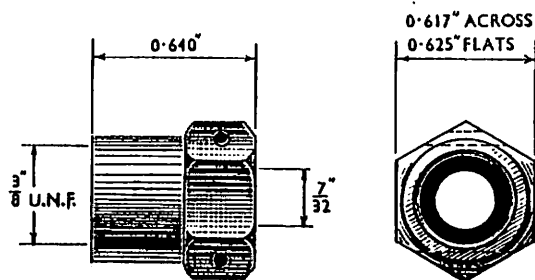

Brown Brothers Engineering Ltd

AS 6688

$\frac{7}{16}$ UNF OUTER SLEEVE
Material: ALUMINIUM ALLOY (ANODISED)

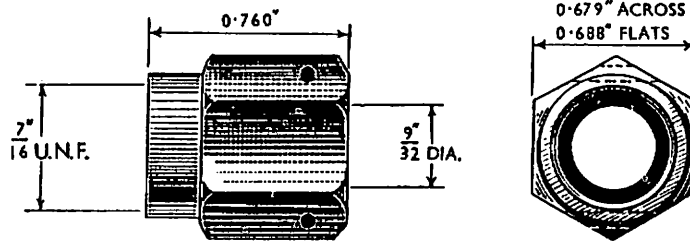

AS 6689

CONE CAP FOR $\frac{3}{8}$ UNF SLEEVE
Material: STEEL (CADMIUM)

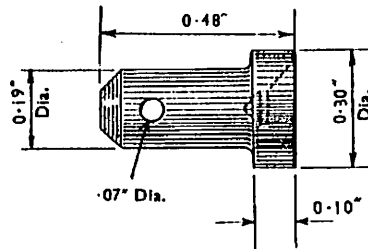

AS 6690

CONE CAP FOR $\frac{7}{16}$ UNF SLEEVE
Material: STEEL (CADMIUM)

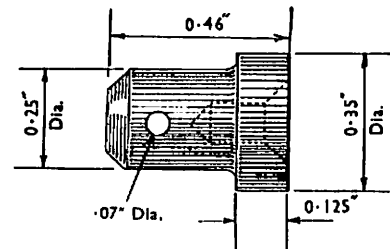

AS 6691 & 6693

CONE UNION ADAPTOR (Unified Attachment End)

Material: ALUMINIUM ALLOY
(ANODISED)

AS 6691 FOR USE WITH PARALLEL GASKETS (e.g. BONDED SEALS)

AS 6693 FOR USE WITH "O" RING GASKETS IN AMERICAN (AND 10050) OR EQUIVALENT AGS 3018 TAPPED BOSSES

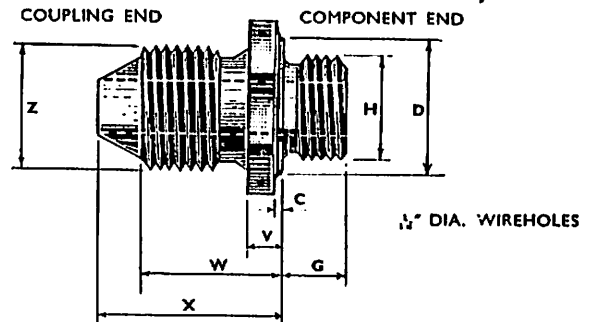

ITEM	O/D OF PIPE	Z THREAD SIZE	COUPLING END—BSP					COMPONENT END—UNIFIED			
			A/F		X	W	Y	H THREAD SIZE	G	D	O
			MIN.	MAX.							
A	$\frac{1}{2}$ "	$\frac{1}{4}$ " BSP	IN. 0.6170	IN. 0.6250	IN. 0.855	IN. 0.635	IN. 0.20	$\frac{1}{2}$ " UNF	IN. 0.35	IN. 0.610	IN. 0.025
B	$\frac{1}{2}$ "	$\frac{1}{4}$ " BSP	0.6759	0.6875	0.945	0.665	0.20	$\frac{3}{8}$ " UNF	0.40	0.670	0.025
BB	$\frac{1}{2}$ "	0.000" x 19 T.P.I. Whit. Form	0.7420	0.7500	1.005	0.685	0.20	$\frac{1}{4}$ " UNF	0.40	0.730	0.025
C	$\frac{1}{2}$ "	$\frac{1}{4}$ " BSP	0.8045	0.8125	1.075	0.755	0.22	$\frac{3}{8}$ " UNF	0.45	0.790	0.025
D	$\frac{1}{2}$ "	$\frac{1}{4}$ " BSP	0.9920	1.0000	1.145	0.825	0.22	$\frac{1}{2}$ " UNF	0.50	0.980	0.025

Brown Brothers Engineering Ltd

AS 6692 & 6694 UNION ADAPTOR (Unified Attachment End)

Material: ALUMINIUM ALLOY (ANODISED)

AS 6692 FOR USE WITH PARALLEL GASKETS (e.g. BONDED SEALS)

AS 6694 FOR USE WITH "O" RING GASKETS IN AMERICAN (AND 10050)
OR EQUIVALENT AGS 3018 TAPPED BOSSES

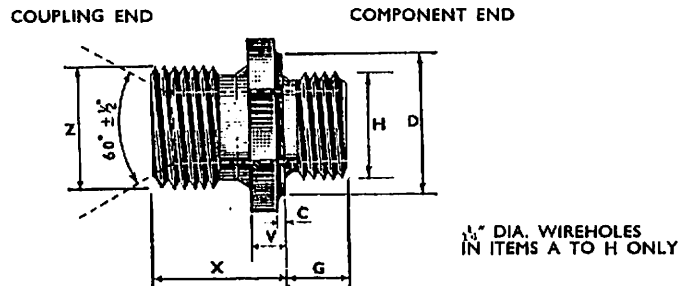

COUPLING END—BSP							COMPONENT END—UNIFIED			
ITEM	O/D OF PIPE	Z THREAD SIZE	A/F		X	V	H THREAD SIZE	G	C	D
			MIN.	MAX.						
A	3/8"	1/4" BSP	IN. 0.8170	IN. 0.6250	IN. 0.65	IN. 0.20	3/8" UNF	IN. 0.35	IN. 0.025	IN. 0.61
B	1/2"	1/2" BSP	0.6795	0.6875	0.65	0.20	1/2" UNF	0.40	0.025	0.67
BB	5/8"	0.600" x 19 T.P.I. Whit. Form	0.7420	0.7500	0.72	0.20	1/2" UNF	0.40	0.025	0.73
C	3/4"	3/4" BSP	0.8045	0.8125	0.74	0.22	3/8" UNF	0.45	0.025	0.79
D	1"	1" BSP	0.9920	1.0000	0.87	0.22	1/2" UNF	0.50	0.025	0.98
E	1 1/8"	1 1/8" BSP	1.1150	1.1250	0.94	0.24	3/4" UNF	0.55	0.035	1.10
F	1 1/4"	1 1/4" BSP	1.3005	1.3125	0.99	0.24	1 1/8" x 12 UNS	0.65	0.035	1.29
H	1 1/2"	1 1/2" BSP	1.6100	1.6250	1.06	0.26	1 1/8" x 12 UNS	0.65	0.035	1.60
J	1 3/4"	1 3/4" BSP	DIA.		1.11	0.26	1 3/8" x 12 UNS	0.65	0.045	2.00
			2.14	2.16						
K	2"	2" BSP	2.35	2.37	1.15	0.26	1 3/4" x 12 UNS	0.65	0.045	2.20
L	2 1/4"	2 1/4" BSP	2.83	2.85	1.25	0.26	2 1/8" x 12 UNS	0.65	0.045	2.70
M	2 1/2"	2 1/2" BSP	3.14	3.16	1.30	0.26	2 1/8" x 12 UNS	0.65	0.045	3.00

Brown Brothers Engineering Ltd

AS 6702 & 6703 BONDING CLIPS

AS 6702 WITH BRASS STRAP

AS 6703 WITH NON-CORRODIBLE STEEL STRAP

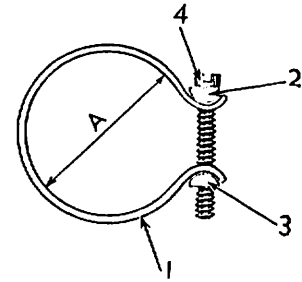

METHOD OF ORDERING

Bonding clips are ordered by the part number followed by the item number representing the "A" dia. in $\frac{1}{16}$ of an inch. (Minimum $\frac{1}{4}$ " Dia.)

ITEM	AS 6702 CONSISTING OF			AS 6703 CONSISTING OF		
	AS 6704	Strap	20 S.W.G. Brass	AS 6705	Strap	20 S.W.G. Non-Corrodible Steel
1	AS 6706	Plain Saddle	Non-Corrodible Steel	AS 6706	Plain Saddle	Non-Corrodible Steel
2	AS 6707	Tapped Saddle	Non-Corrodible Steel	AS 6707	Tapped Saddle	Non-Corrodible Steel
3	BS A207	Screw	Non-Corrodible Steel	BS A207	Screw	Non-Corrodible Steel

AS 6704 STRAP (for AS 6702)

Material: BRASS (20 S.W.G.)

AS 6705 STRAP (for AS 6703)

Material: NON-CORRODIBLE STEEL (20 S.W.G.)

AS 6706 SADDLE, PLAIN (for AS 6702 & 6703)

Material: NON-CORRODIBLE STEEL

AS 6707 SADDLE, TAPPED (for AS 6702 & 6703)

Material: NON-CORRODIBLE STEEL

**AS 6709 LOW PRESSURE UNION ASSEMBLIES
(for $\frac{3}{8}$ " dia. tubing)**

STRAIGHT UNION	ELBOW UNION	TEE UNION	STR. UNION WITH DRAIN TRAP
1 OFF AS 6710	1 OFF AS 6712	1 OFF AS 6711	1 OFF AS 6711
2 OFF AS 8599	2 OFF AS 8599	3 OFF AS 8599	2 OFF AS 8599
			1 OFF AS 8595
			2 OFF AS 8596

Brown Brothers Engineering Ltd

AS 6710

STRAIGHT UNION BODY



Material: ALUMINIUM ALLOY (ANODISED)

Across Flats = 0.679/0.688
Threads = $\frac{9}{16}$ "—28 T.P.I. UNS
Overall Length = 0.675"

AS 6711

TEE UNION BODY

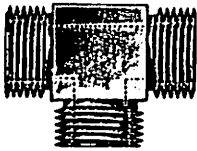

Material: ALUMINIUM ALLOY (ANODISED)

Threads = $\frac{9}{16}$ "—28 T.P.I. UNS

AS 6712

ELBOW UNION BODY

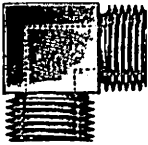

Material: ALUMINIUM ALLOY (ANODISED)

Threads = $\frac{9}{16}$ "—28 T.P.I. UNS

AS 6713

UNION NUT



(Replaced by
AS 8590)

Material: ALUMINIUM ALLOY (ANODISED)

Threads = $\frac{9}{16}$ "—28 T.P.I. UNS
Across Flats = 0.679"/0.688"
Overall Length = 0.44"

AS 6714

BUSH



(Replaced by
AS 8590)

Material: RUBBER

Bore = 0.37" O/D = 0.51" Length = 0.25"

AS 6715

ADAPTOR UNION BODY

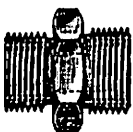

Material: ALUMINIUM ALLOY (ANODISED)

Threads = $\frac{1}{2}$ "—26 T.P.I. Whitform; $\frac{9}{16}$ "—28 T.P.I. UNS
Across Flats = 0.679"/0.688"
Overall Length = 0.675"

AS 6716 TRANSPORTATION PLUGS (Unified Threads)

ITEM	Z THREAD	ACROSS FLATS		Y	X
		MIN.	MAX.		
A	$\frac{1}{4}$ " UNF	IN. 0.617	IN. 0.625	IN. 0.46	IN. 0.30
B	$\frac{3}{8}$ " UNF	0.680	0.688	0.50	0.32
BB	$\frac{1}{2}$ " UNF	0.742	0.750	0.51	0.33
C	$\frac{5}{8}$ " UNF	0.805	0.813	0.53	0.34
CC	$\frac{3}{4}$ " UNF	0.867	0.875	0.57	0.37
D	$\frac{7}{8}$ " UNF	0.992	1.000	0.62	0.41
E	1" UNF	1.115	1.125	0.64	0.42
F	1 $\frac{1}{8}$ "-12 UNS	1.301	1.313	0.67	0.43
G	1 $\frac{1}{4}$ "-12 UNS	1.423	1.438	0.72	0.46
H	1 $\frac{3}{8}$ "-12 UNS	1.610	1.625	0.80	0.53
J	1 $\frac{1}{2}$ "-12 UNS	2.140	2.160	0.86	0.55
K	1 $\frac{3}{4}$ "-12 UNS	2.350	2.370	0.91	0.60

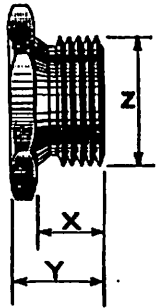

Material:
BRASS (SELF)

AS 6717 JOINTING WASHERS (For Unified Plugs)

ITEM	A	B
A	IN. 0.39	IN. 0.63
B	0.45	0.60
BB	0.52	0.75
C	0.58	0.81
CC	0.64	0.88
D	0.77	1.00
E	0.80	1.13
F	1.08	1.31
G	1.20	1.44
H	1.33	1.63
J	1.64	2.16
K	1.80	2.37

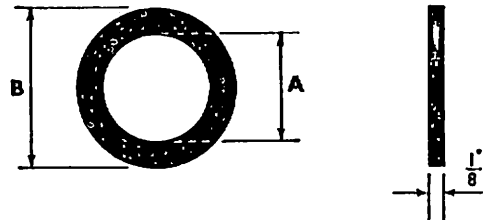

Material: VULCANISED FIBRE

Brown Brothers Engineering Ltd

AS 6720

**CONE & UNION BANJOS
(GENERAL ARRANGEMENTS)**

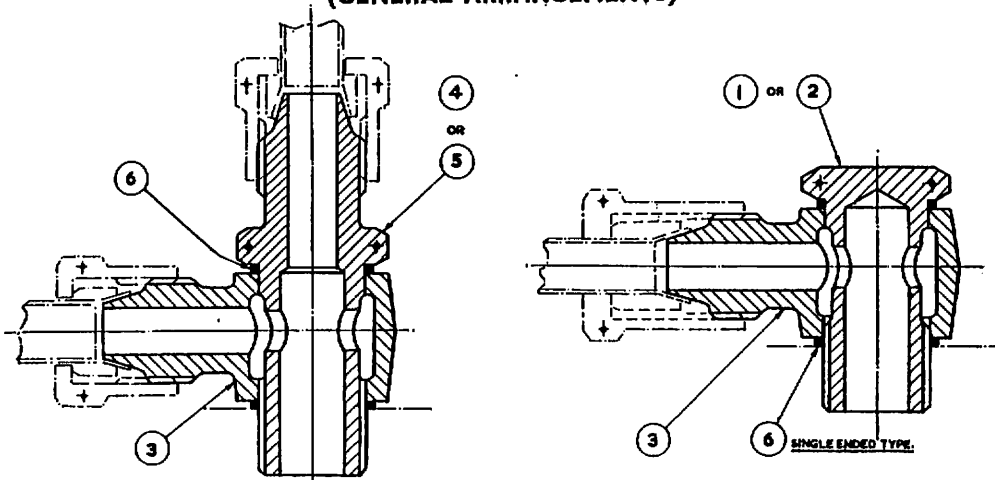

**SINGLE ENDED TYPE WITH
END CONNECTION BOLT.**

ITEM	PART No.	DESCRIPTION
1	AS 6721	Banjo Bolt (Alum. Alloy)
2	AS 6722	Banjo Bolt (Steel)
3	AS 6727	Single End Cone Banjo Body
4	AS 6723	Banjo Bolt with Cone End (Alum. Alloy)
5	AS 6724	Banjo Bolt with Cone End (Steel)
6	AGS 1186	Seal, Bonded Steel and Synthetic Rubber

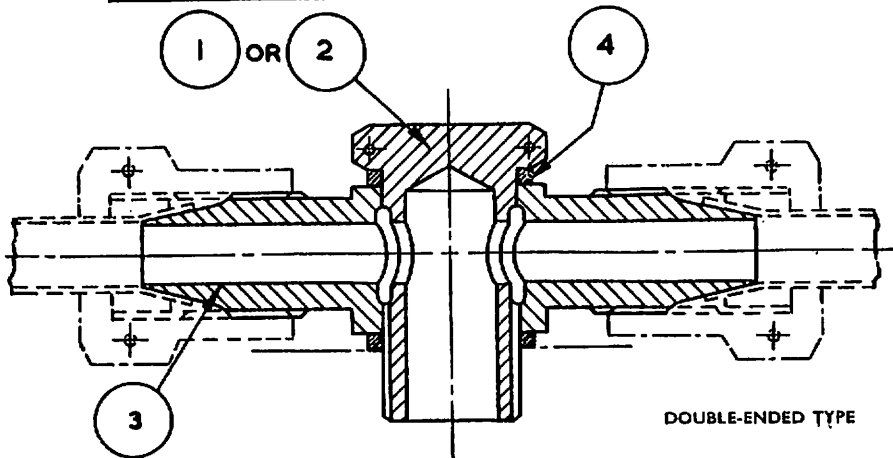

DOUBLE-ENDED TYPE

ITEM	PART No.	DESCRIPTION
1	AS 6721	Banjo Bolt (Alum. Alloy)
2	AS 6722	Banjo Bolt (Steel)
3	AS 6728	Double End Cone Banjo Body
4	AGS 1186	Seal, Bonded Steel and Synthetic Rubber

Brown Brothers Engineering Ltd

AS 6720

CONE & UNION BANJOS—continued (GENERAL ARRANGEMENTS)

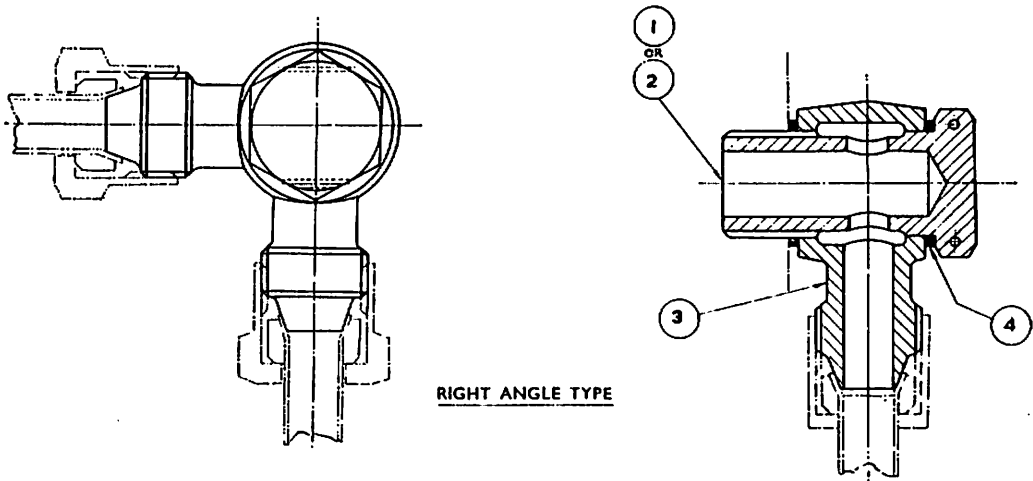

RIGHT ANGLE TYPE

ITEM	PART NO.	DESCRIPTION
1	AS 6721	Banjo Bolt (Alum. Alloy)
2	AS 6722	Banjo Bolt (Steel)
3	AS 6720	Double R.A. Cone Banjo Body
4	AGS 1186	Seal, Bonded Steel and Synthetic Rubber

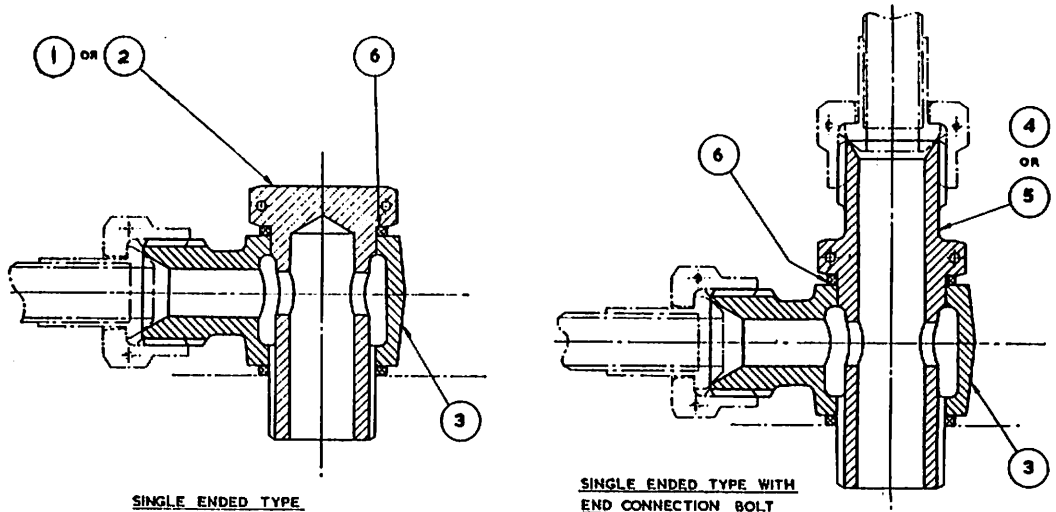

SINGLE ENDED TYPE

SINGLE ENDED TYPE WITH
END CONNECTION BOLT

ITEM	PART No.	DESCRIPTION
1	AS 6721	Banjo Bolt (Alum. Alloy)
2	AS 6722	Banjo Bolt (Steel)
3	AS 6730	Single End Union Banjo Body
4	AS 6726	Banjo Bolt with Union Head Connection (Steel)
5	AS 6725	Banjo Bolt with Union Head Connection (Alum. Alloy)
6	AGS 1186	Seal, Bonded Steel and Synthetic Rubber

Brown Brothers Engineering Ltd

AS 6720

CONE & UNION BANJOS—continued (GENERAL ARRANGEMENTS)

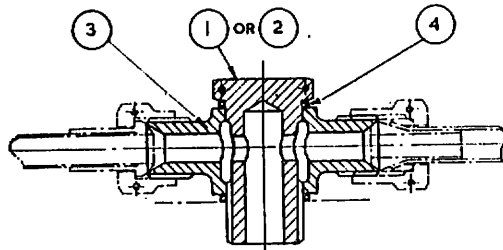

DOUBLE ENDED TYPE

ITEM	PART No.	DESCRIPTION
1	AS 6721	Banjo Bolt (Alum. Alloy)
2	AS 6722	Banjo Bolt (Steel)
3	AS 6731	Double End Union Banjo Body
4	AGS 1186	Seal, Bonded Steel and Synthetic Rubber

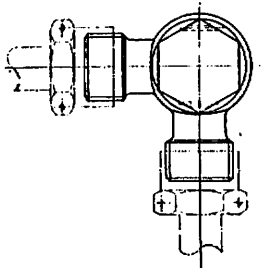

RIGHT ANGLE TYPE

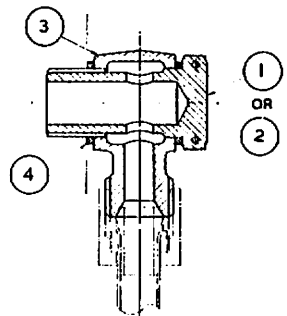

ITEM	PART No.	DESCRIPTION
1	AS 6721	Banjo Bolt (Alum. Alloy)
2	AS 6722	Banjo Bolt (Steel)
3	AS 6732	Double R.A. Union Banjo Body
4	AGS 1186	Seal, Bonded Steel and Synthetic Rubber

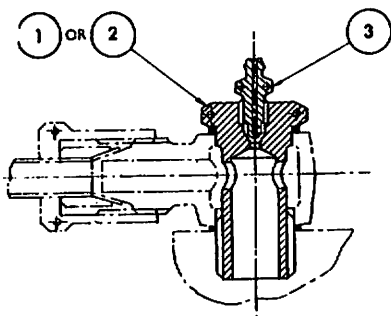

BANJO BOLTS WITH BLEEDER SCREWS

ITEM	PART No.	DESCRIPTION
1	AS 6758	Banjo Bolt (Steel)
2	AS 6759	Banjo Bolt (Alum. Alloy)
3	AGS 3049	Bleeder Screw

Brown Brothers Engineering Ltd

AS 6721 BANJO BOLT (Unified Adaptor)

Material: ALUMINIUM ALLOY (ANODISED)

Item A has one cross hole only

Working Pressures:

3,000 lb./sq. in. for sizes up to $\frac{3}{4}$ " UNF
 500 lb./sq. in. for sizes $\frac{1}{8}$ " UNF to $1\frac{1}{16}$ " UNS

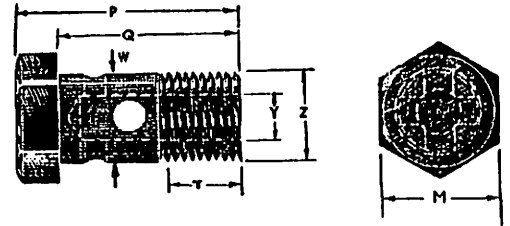

ITEM	O/D OF PIPE	Z	M		P	Q	T MIN.	W DIA.	Y DRILL
			MIN.	MAX.					
A	$\frac{1}{8}$ "	$\frac{1}{4}$ " UNF	IN. 0.617	IN. 0.625	IN. 1.36	IN. 1.01	IN. 0.43	IN. 0.375	0.144"
B	$\frac{1}{4}$ "	$\frac{1}{2}$ " UNF	0.680	0.688	1.44	1.11	0.45	0.437	0.144"
BB	$\frac{1}{8}$ "	$\frac{1}{4}$ " UNF	0.742	0.750	1.60	1.26	0.45	0.500	$\frac{1}{8}$ "
C	$\frac{1}{4}$ "	$\frac{1}{2}$ " UNF	0.805	0.813	1.70	1.36	0.49	0.562	$\frac{3}{16}$ "
CC	$\frac{1}{8}$ "	$\frac{1}{4}$ " UNF	0.867	0.875	1.85	1.51	0.52	0.625	0.302"
D	$\frac{1}{2}$ "	$\frac{3}{4}$ " UNF	0.992	1.000	1.98	1.66	0.59	0.750	$\frac{1}{2}$ "
E	$\frac{3}{4}$ "	$\frac{1}{2}$ " UNF	1.115	1.125	2.10	1.76	0.59	0.875	$\frac{3}{8}$ "
F	$\frac{1}{2}$ "	$1\frac{1}{4}$ " UNS x 12	1.301	1.313	2.31	1.96	0.65	1.061	$\frac{1}{2}$ "
G	$\frac{3}{4}$ "	$1\frac{1}{4}$ " UNS x 12	1.423	1.435	2.55	2.16	0.69	1.187	$\frac{3}{4}$ "
H	1"	$1\frac{1}{4}$ " UNS x 12	1.610	1.625	2.91	2.54	0.75	1.312	$\frac{3}{4}$ "

AS 6722 BANJO BOLT (Unified Adaptor)

Material: STEEL (CADMIUM)

Working Pressures:

3,000 lb./sq. in. for sizes up to $\frac{3}{4}$ " UNF
 500 lb./sq. in. for sizes $\frac{1}{8}$ " UNF to $1\frac{1}{16}$ " UNS

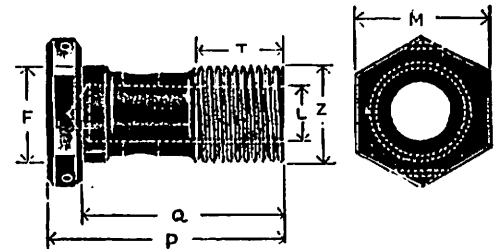

ITEM	O/D OF PIPE	Z	M		F	I ₁ DRILL	P	Q	T
			MIN.	MAX.					
A	$\frac{1}{8}$ "	$\frac{1}{4}$ " UNF	IN. 0.617	IN. 0.625	IN. 0.375	0.144"	IN. 1.36	IN. 1.005	IN. 0.54
B	$\frac{1}{4}$ "	$\frac{1}{2}$ " UNF	0.680	0.688	0.437	0.144"	1.44	1.105	0.54
BB	$\frac{1}{8}$ "	$\frac{1}{4}$ " UNF	0.742	0.750	0.500	$\frac{1}{8}$ "	1.60	1.255	0.61
C	$\frac{1}{4}$ "	$\frac{1}{2}$ " UNF	0.805	0.813	0.562	0.281"	1.70	1.355	0.61
CC	$\frac{1}{8}$ "	$\frac{1}{4}$ " UNF	0.867	0.875	0.625	0.339"	1.85	1.505	0.69
D	$\frac{1}{2}$ "	$\frac{3}{4}$ " UNF	0.992	1.000	0.750	$\frac{1}{4}$ "	1.98	1.655	0.74
E	$\frac{3}{4}$ "	$\frac{1}{2}$ " UNF	1.115	1.125	0.875	$\frac{3}{16}$ "	2.10	1.755	0.74
F	$\frac{1}{2}$ "	$1\frac{1}{4}$ " UNS x 12	1.301	1.313	1.061	$\frac{1}{2}$ "	2.31	1.955	0.84
G	$\frac{3}{4}$ "	$1\frac{1}{4}$ " UNS x 12	1.423	1.435	1.187	$\frac{3}{4}$ "	2.55	2.155	0.89
H	1"	$1\frac{1}{4}$ " UNS x 12	1.610	1.625	1.312	$\frac{3}{4}$ "	2.91	2.535	0.98

Brown Brothers Engineering Ltd

AS 6723

BANJO BOLT (Unified Adaptor)

Material: ALUMINIUM ALLOY (ANODISED)

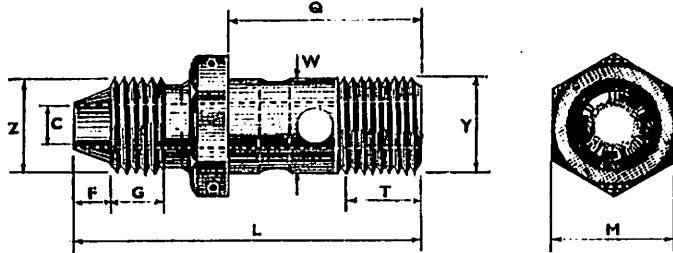

Working Pressure:
3,000 lb./sq. in.

Item A has one cross hole only

ITEM	O/D OF PIPE	Z	Y	M		Ø DRILL	F	G MIN.	L	Q	T MIN.	W
				MIN.	MAX.							
A	1/8"	1/2" BSP	1/2" UNF	IN. 0.617	IN. 0.825	3/8"	IN. 0.225	IN. 0.36	IN. 1.98	IN. 1.01	IN. 0.43	IN. 0.375
B	1/2"	1/2" BSP	3/8" UNF	0.680	0.688	0.144"	0.285	0.39	2.22	1.11	0.45	0.437
BB	1/8"	0.600" x 19 T.P.I. Whit.	1/2" UNF	0.712	0.750	1/4"	0.325	0.40	2.41	1.26	0.45	0.500
C	1/2"	1/2" BSP	1/8" UNF	0.805	0.813	1/2"	0.325	0.42	2.54	1.36	0.49	0.562
CC	1/8"	0.75" x 14 T.P.I. Whit.	1/2" UNF	0.867	0.875	0.302"	0.325	0.47	2.83	1.51	0.52	0.625
D	1/2"	1/2" BSP	1/2" UNF	0.992	1.000	1"	0.325	0.48	2.99	1.66	0.59	0.750

AS 6724

BANJO BOLT (Unified Adaptor)

Material: STEEL (CADMIUM)

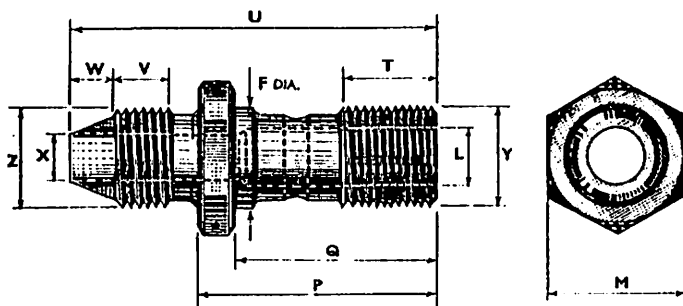

Working Pressure:
3,000 lb./sq. in.

ITEM	O/D OF PIPE	Z	Y	M	F	L DRILL	P	Q	T	U	X DRILL	W	Y MIN.
B	1/2"	1/2" BSP	1/8" UNF	0.680 0.688	0.437	0.144"	1.30	1.105	0.54	2.22	0.144"	0.285	0.39
BB	1/8"	0.600" x 19 T.P.I. Whit.	1/2" UNF	0.712 0.750	0.500	1/4"	1.51	1.255	0.61	2.41	1/4"	0.325	0.40
C	1/2"	1/2" BSP	1/8" UNF	0.805 0.813	0.562	0.281"	1.61	1.355	0.61	2.54	1/2"	0.325	0.42
CC	1/8"	0.75" x 14 T.P.I. Whit.	1/2" UNF	0.867 0.875	0.625	0.339"	1.79	1.605	0.69	2.83	1/4"	0.325	0.47
D	1/2"	1/2" BSP	1/2" UNF	0.992 1.000	0.750	1/2"	1.94	1.655	0.74	2.99	1/2"	0.325	0.48

AS 6725

BANJO BOLT (Unified Adaptor)

Material:
ALUMINIUM ALLOY (ANODISED)

Working Pressures:
3,000 lb./sq. in. for sizes up to 1/2" BSP
500 lb./sq. in. for sizes 3/8" to 1" BSP
Item A has one cross hole only

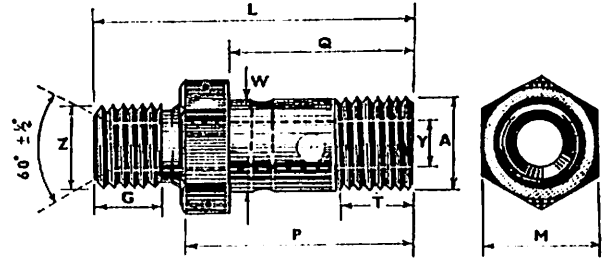

ITEM	O/D OF PIPE	Z	A	M		G MIN.	L	P	Q	T MIN.	Y DRILL	W
				MIN.	MAX.							
A	1/2"	1" BSP	3/4" UNF	0.617	0.625	0.35	1.75	1.260	1.01	0.43	0.144	0.375
B	1/2"	1" BSP	3/4" UNF	0.680	0.688	0.35	1.90	1.360	1.11	0.45	0.144	0.437
BB	1/2"	0.600" x 10 T.P.I. WHIT.	1" UNF	0.742	0.750	0.40	2.09	1.510	1.26	0.45	1/8"	0.500
C	1/2"	3/4" BSP	1" UNF	0.805	0.813	0.40	2.19	1.610	1.36	0.49	3/16"	0.562
CC	1/2"	0.75" x 14 T.P.I. WHIT.	1" UNF	0.867	0.875	0.45	2.53	1.790	1.51	0.52	0.302	0.625
D	1/2"	1" BSP	1 1/4" UNF	0.992	1.000	0.53	2.71	1.940	1.65	0.59	1/4"	0.750
E	1/2"	1" BSP	1 1/4" UNF	1.115	1.125	0.55	2.85	2.060	1.76	0.59	3/16"	0.875
F	3/4"	1" BSP	1 1/2" UNS x 12	1.301	1.313	0.55	3.05	2.260	1.96	0.65	1/4"	1.061
G	3/4"	1" BSP	1 1/2" UNS x 12	1.423	1.438	0.65	3.40	2.510	2.16	0.69	3/16"	1.187
H	1"	1" BSP	1 1/2" UNS x 12	1.610	1.625	0.70	3.89	2.010	2.51	0.76	3/16"	1.312

AS 6726

BANJO BOLT (Unified Adaptor)

Material: STEEL (CADMIUM)

Working Pressures:
3,000 lb./sq. in. for sizes up to 1/2" BSP
500 lb./sq. in. for sizes 3/8" BSP to 1" BSP

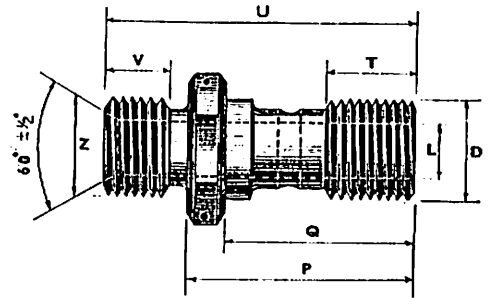

ITEM	O/D OF PIPE	Z	D	M		L DRILL	P	Q	T	U	V MIN.
				MIN.	MAX.						
A	1/2"	1" BSP	3/4" UNF	0.617	0.625	0.144"	1.26	1.005	0.51	1.75	0.35
B	1/2"	1" BSP	3/4" UNF	0.680	0.688	0.144"	1.36	1.105	0.54	1.90	0.35
BB	1/2"	0.600" x 10 T.P.I. WHIT.	1" UNF	0.742	0.750	3/16"	1.51	1.255	0.61	2.09	0.40
C	1/2"	3/4" BSP	1" UNF	0.805	0.813	0.281"	1.61	1.355	0.61	2.19	0.40
CC	1/2"	0.75" x 14 T.P.I. WHIT.	1" UNF	0.867	0.875	0.339"	1.79	1.505	0.69	2.53	0.45
D	1/2"	1" BSP	1 1/4" UNF	0.992	1.000	1/4"	1.94	1.655	0.74	2.71	0.53
E	1/2"	1" BSP	1 1/4" UNF	1.115	1.125	3/16"	2.06	1.755	0.74	2.85	0.55
F	3/4"	1" BSP	1 1/2" UNS x 12	1.301	1.313	1/4"	2.26	1.955	0.84	3.05	0.55
G	3/4"	1" BSP	1 1/2" UNS x 12	1.423	1.438	3/16"	2.51	2.155	0.89	3.40	0.65
H	1"	1" BSP	1 1/2" UNS x 12	1.610	1.625	3/16"	2.89	2.635	0.98	3.89	0.70

Brown Brothers Engineering Ltd

AS 6727 SINGLE-ENDED CONE BANJO BODY

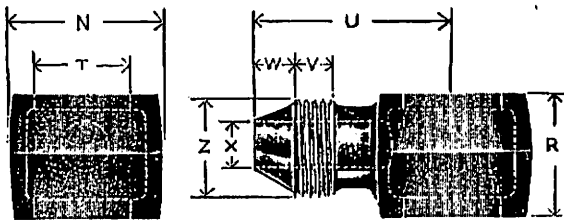

Material:
ALUMINIUM ALLOY (ANODISED)

Working Pressure: 3,000 lb./sq. in.

ITEM	O/D OF PIPE	Z	X DRILL	W	V	U	T DIA.	R	N
A	3/8"	1/4" BSP	3/16"	IN. 0.225	IN. 0.30	IN. 1.05	IN. 0.3815	IN. 0.50	IN. 0.765
B	1/2"	1/4" BSP	3/16"	0.285	0.30	1.22	0.4435	0.60	0.915
BB	3/8"	0.600" x 19 T.P.I. Whit.	3/16"	0.325	0.34	1.35	0.5065	0.70	1.015
C	1/2"	1/4" BSP	1/8"	0.325	0.37	1.43	0.5685	0.80	1.115
CC	3/8"	0.75" x 14 T.P.I. Whit.	3/16"	0.325	0.39	1.56	0.6315	0.90	1.215
D	1/2"	1/4" BSP	1/8"	0.325	0.40	1.62	0.7665	1.00	1.315

AS 6728 DOUBLE-ENDED CONE BANJO BODY

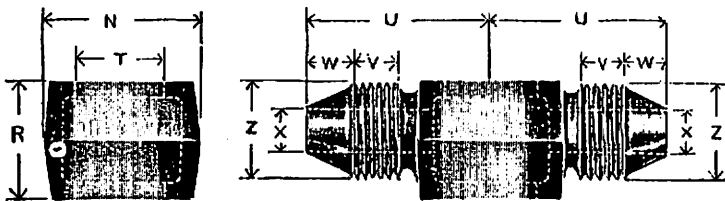

Material:
ALUMINIUM ALLOY (ANODISED)

Working Pressure:
3,000 lb./sq. in.

ITEM	O/D OF PIPE	Z	X DRILL	W	V	U	T DIA.	R	N
A	3/8"	1/4" BSP	3/16"	IN. 0.225	IN. 0.30	IN. 1.05	IN. 0.3815	IN. 0.50	IN. 0.765
B	1/2"	1/4" BSP	3/16"	0.285	0.30	1.22	0.4435	0.60	0.915
BB	3/8"	0.600" x 19 T.P.I. Whit.	3/16"	0.325	0.34	1.35	0.5065	0.70	1.015
C	1/2"	1/4" BSP	1/8"	0.325	0.37	1.43	0.5685	0.80	1.115
CC	3/8"	0.75" x 14 T.P.I. Whit.	3/16"	0.325	0.39	1.56	0.6315	0.90	1.215
D	1/2"	1/4" BSP	1/8"	0.325	0.40	1.62	0.7665	1.00	1.315

AS 6729 DOUBLE R.A. CONE BANJO BODY

Material:
ALUMINIUM ALLOY (ANODISED)

Working Pressure: 3,000 lb./sq. in.

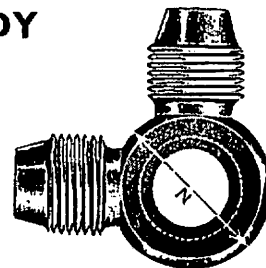
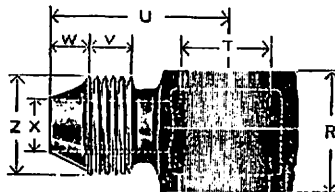

ITEM	O/D OF PIPE	Z	X DRILL	W	V	U	T DIA.	R	N
A	3/8"	1/4" BSP	3/16"	IN. 0.225	IN. 0.30	IN. 1.05	IN. 0.3815	IN. 0.50	IN. 0.765
B	1/2"	1/4" BSP	3/16"	0.285	0.30	1.22	0.4435	0.60	0.915
BB	3/8"	0.600" x 19 T.P.I. Whit.	3/16"	0.325	0.34	1.35	0.5065	0.70	1.015
C	1/2"	1/4" BSP	1/8"	0.325	0.37	1.43	0.5685	0.80	1.115
CC	3/8"	0.75" x 14 T.P.I. Whit.	3/16"	0.325	0.39	1.56	0.6315	0.90	1.215
D	1/2"	1/4" BSP	1/8"	0.325	0.40	1.62	0.7665	1.00	1.315

Brown Brothers Engineering Ltd

AS 6730

SINGLE-END BANJO BODY

Material: ALUMINIUM ALLOY (ANODISED)

Working Pressures:

3,000 lb./sq. in. for sizes up to ½" BSP
 500 lb./sq. in. for sizes ¾" BSP to 1" BSP

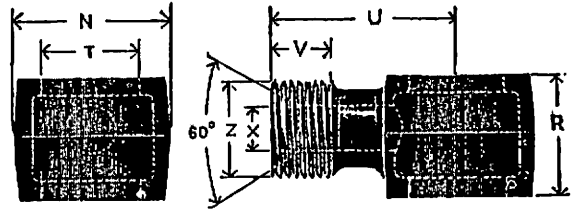

ITEM	O/D OF PIPE	Z	X DRILL	V	U	T DIA.	R	N
A	½"	½" BSP	⅜"	IN. 0.35	IN. 0.87	IN. 0.3815	IN. 0.60	IN. 0.765
B	¾"	½" BSP	⅜"	0.35	1.00	0.4435	0.60	0.915
BB	½"	0.600" x 19 T.P.I. Whit.	⅜"	0.40	1.10	0.5065	0.70	1.015
C	¾"	¾" BSP	½"	0.40	1.15	0.5685	0.80	1.115
CC	½"	0.75" x 14 T.P.I. Whit.	⅜"	0.45	1.30	0.6315	0.90	1.215
D	¾"	¾" BSP	½"	0.50	1.40	0.7665	1.00	1.315
E	1"	¾" BSP	½"	0.55	1.58	0.8815	1.10	1.565
F	¾"	¾" BSP	½"	0.61	1.79	1.0875	1.25	1.865
G	¾"	¾" BSP	½"	0.65	1.93	1.1935	1.40	2.065
H	1"	1" BSP	½"	0.65	2.05	1.3185	1.65	2.215

AS 6731

DOUBLE-ENDED BANJO BODY

Material: ALUMINIUM ALLOY (ANODISED)

Working Pressures:

3,000 lb./sq. in. for sizes up to ½" BSP
 500 lb./sq. in. for sizes ¾" BSP to 1" BSP

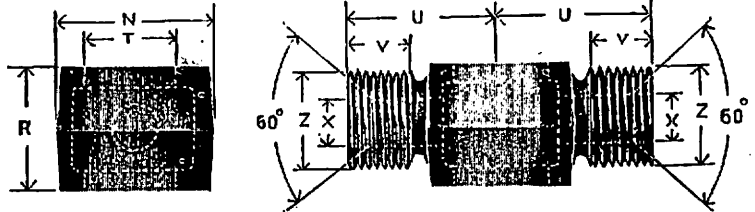

ITEM	O/D OF PIPE	Z	X DRILL	V	U	T DIA.	R	N
A	½"	½" BSP	⅜"	IN. 0.35	IN. 0.87	IN. 0.3815	IN. 0.50	IN. 0.765
B	¾"	½" BSP	⅜"	0.35	1.00	0.4435	0.60	0.915
BB	½"	0.600" x 19 T.P.I. Whit.	⅜"	0.40	1.10	0.5065	0.70	1.015
C	¾"	¾" BSP	½"	0.40	1.15	0.5685	0.80	1.115
CC	½"	0.75" x 14 T.P.I. Whit.	⅜"	0.45	1.30	0.6315	0.90	1.215
D	¾"	¾" BSP	½"	0.50	1.40	0.7665	1.00	1.315
E	1"	¾" BSP	½"	0.55	1.58	0.8815	1.10	1.565
F	¾"	¾" BSP	½"	0.61	1.79	1.0875	1.25	1.865
G	¾"	¾" BSP	½"	0.65	1.93	1.1935	1.40	2.065
H	1"	1" BSP	½"	0.65	2.05	1.3185	1.65	2.215

Brown Brothers Engineering Ltd

AS 6732

DOUBLE R.A. UNION BANJO BODY

Material: ALUMINIUM ALLOY (ANODISED)

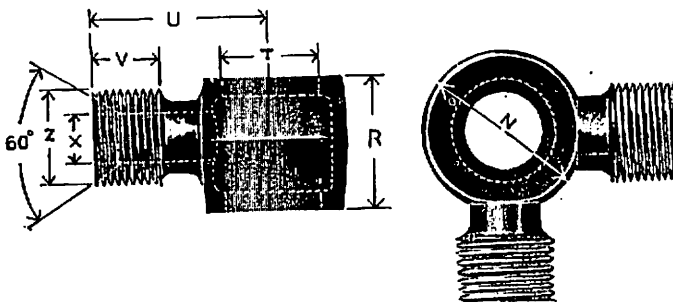

Working Pressures:

3,000 lb./sq.in. for sizes up to 1/2" BSP
 500 lb./sq.in. for sizes 3/8" BSP to 1" BSP

ITEM	O/D OF PIPE	Z	X DRILL	V		U		T DIA.		R		N DIA.	
				IN.	IN.	IN.	IN.	IN.	IN.	IN.	IN.		
A	3/8"	1/2" BSP	3/16"	0.35	0.87	0.3815	0.50	0.705					
B	1/2"	1/2" BSP	1/8"	0.35	1.00	0.4435	0.60	0.915					
BB	3/8"	0.600" x 19 T.P.I. Whit.	3/16"	0.40	1.10	0.5065	0.70	1.015					
C	1/2"	1/2" BSP	1/8"	0.40	1.16	0.5685	0.80	1.115					
CC	1/2"	0.75" x 14 T.P.I. Whit.	3/16"	0.45	1.30	0.6315	0.90	1.215					
D	1/2"	1/2" BSP	1/8"	0.50	1.40	0.7665	1.00	1.315					
E	1/2"	1/2" BSP	1/8"	0.55	1.58	0.8815	1.10	1.505					
F	1/2"	1/2" BSP	1/8"	0.61	1.79	1.0675	1.25	1.865					
G	1/2"	1/2" BSP	1/8"	0.65	1.93	1.1955	1.40	2.005					
H	1"	1" BSP	1/8"	0.65	2.05	1.3185	1.65	2.215					

AS 6733

WIRE THREAD INSERTS (UNF)

Material: NON-CORRODIBLE STEEL (SELF)
 Details and prices on application

AS 6734

WIRE THREAD INSERTS (UNC)

Material: NON-CORRODIBLE STEEL (SELF)
 Details and prices on application

AS 6742 & 6743

FILLER CAPS MARK 2

(UNIFIED THREADS) (FLUSH TYPE)

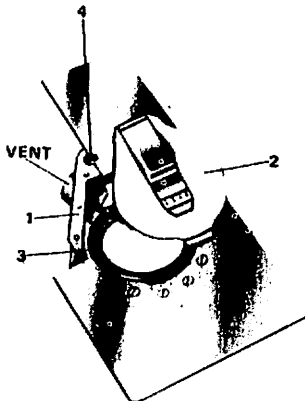

ITEM	COMPRISING	PART NUMBERS	
		AS 6742 WITH VENT	AS 6743 WITHOUT VENT
1	Base	AS 6744	AS 6745
2	Cap	AS 6746	
3	Sealing Ring	AS 5364	
4	Bonding Socket	AS 6322	

Brown Brothers Engineering Ltd

AS 6758

BANJO BOLT

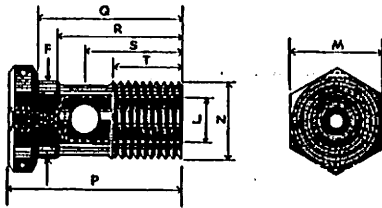

Material: HIGH TENSILE STEEL (CADMIUM)

Working pressures:

3,000 lb./sq. in. for sizes up to $\frac{3}{4}$ " U.N.F.
500 lb./sq. in. for sizes $\frac{7}{8}$ " U.N.F. to $1\frac{5}{8}$ " U.N.S.

ITEM	O/DIA. OF PIPE	Z THREAD	F DIA.	L DIA.	M		P	Q	R	S	T
					MAX.	MIN.					
A	$\frac{1}{2}$ "	1" U.N.F.	IN. 0.375	IN. 0.144	IN. 0.625	IN. 0.617	1.360	1.005	0.835	0.720	0.540
B	$\frac{3}{4}$ "	$\frac{1}{2}$ " U.N.F.	0.437	0.144	0.688	0.680	1.440	1.105	0.935	0.750	0.540
BB	$\frac{1}{2}$ "	$\frac{1}{4}$ " U.N.F.	0.500	$\frac{1}{8}$ "	0.750	0.742	1.600	1.255	1.065	0.880	0.610
C	$\frac{3}{4}$ "	$\frac{3}{8}$ " U.N.F.	0.562	0.281	0.813	0.805	1.700	1.355	1.165	0.950	0.610
CC	$\frac{1}{2}$ "	1" U.N.F.	0.625	0.339	0.875	0.867	1.850	1.505	1.285	1.050	0.690
D	$\frac{3}{4}$ "	$\frac{1}{2}$ " U.N.F.	0.750	$\frac{3}{8}$ "	1.000	0.992	1.980	1.655	1.435	1.140	0.740
E	1"	$\frac{1}{2}$ " U.N.F.	0.875	$\frac{1}{2}$ "	1.125	1.115	2.000	1.755	1.535	1.200	0.740
F	$\frac{3}{4}$ "	1 $\frac{1}{8}$ "-12 U.N.S.	1.061	$\frac{1}{2}$ "	1.313	1.301	2.310	1.955	1.685	1.330	0.840
G	$\frac{3}{4}$ "	1 $\frac{1}{8}$ "-12 U.N.S.	1.187	$\frac{3}{4}$ "	1.438	1.423	2.550	2.155	1.885	1.480	0.890
H	1"	1 $\frac{1}{8}$ "-12 U.N.S.	1.312	$\frac{1}{2}$ "	1.625	1.610	2.910	2.535	2.225	1.720	0.980

AS 6759

BANJO BOLT

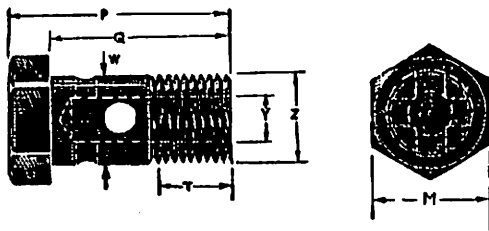

Material: ALUMINIUM ALLOY (ANODISED)

Working pressures:

3,000 lb./sq. in. for sizes up to $\frac{3}{4}$ " U.N.F.
5,000 lb./sq. in. for sizes $\frac{7}{8}$ " U.N.F. to $1\frac{5}{8}$ " U.N.S.

ITEM	O/DIA. OF PIPE	Z THREAD	M		P	Q	T MIN.	W DIA.	Y DIA.
			MAX.	MIN.					
A	$\frac{1}{2}$ "	1" U.N.F.	IN. 0.625	IN. 0.617	IN. 1.360	IN. 1.010	IN. 0.430	IN. 0.375	IN. 0.144
B	$\frac{3}{4}$ "	$\frac{1}{2}$ " U.N.F.	0.688	0.680	1.440	1.110	0.450	0.437	0.144
BB	$\frac{1}{2}$ "	$\frac{1}{4}$ " U.N.F.	0.750	0.742	1.600	1.260	0.450	0.500	$\frac{1}{8}$ "
C	$\frac{3}{4}$ "	$\frac{3}{8}$ " U.N.F.	0.813	0.805	1.700	1.360	0.490	0.562	$\frac{3}{16}$ "
CC	$\frac{1}{2}$ "	1" U.N.F.	0.875	0.867	1.850	1.510	0.520	0.625	0.302
D	$\frac{3}{4}$ "	$\frac{1}{2}$ " U.N.F.	1.000	0.992	1.980	1.660	0.590	0.750	1"
E	1"	$\frac{1}{2}$ " U.N.F.	1.125	1.115	2.100	1.760	0.590	0.875	$\frac{1}{2}$ "
F	$\frac{3}{4}$ "	1 $\frac{1}{8}$ "-12 U.N.S.	1.313	1.301	2.310	1.960	0.650	1.061	$\frac{1}{2}$ "
G	$\frac{3}{4}$ "	1 $\frac{1}{8}$ "-12 U.N.S.	1.438	1.423	2.550	2.160	0.690	1.187	$\frac{1}{2}$ "
H	1"	1 $\frac{1}{8}$ "-12 U.N.S.	1.625	1.610	2.910	2.540	0.750	1.312	$\frac{1}{2}$ "

Brown Brothers Engineering Ltd

AS 6760 to AS 6804

SMALL ROUND HEAD BOLTS

No. 10-32 U.N.F. THREAD

Material: HIGH TENSILE STEEL (CADMIUM)

Details available on request

AS 6850 to AS 6894

LARGE ROUND HEAD BOLTS

No. 10-32 U.N.F. THREAD

Material: HIGH TENSILE STEEL (CADMIUM)

Details available on request

AS 6895 to AS 6939

SMALL ROUND HEAD BOLTS

$\frac{1}{4}$ " U.N.F. THREAD

Material: HIGH TENSILE STEEL (CADMIUM)

Details available on request

AS 6985 to AS 7032

LARGE ROUND HEAD BOLTS

$\frac{1}{4}$ " U.N.F. THREAD

Material: HIGH TENSILE STEEL (CADMIUM)

Details available on request

AS 7033 to AS 7077

SMALL ROUND HEAD BOLTS

$\frac{5}{16}$ " U.N.F. THREAD

Material: HIGH TENSILE STEEL (CADMIUM)

Details available on request

Brown Brothers Engineering Ltd

AS 7123 to AS 7170

LARGE ROUND HEAD BOLTS

$\frac{5}{16}$ " U.N.F. THREAD

Material: HIGH TENSILE STEEL (CADMIUM)

Details available on request

AS 7171 to AS 7215

SMALL ROUND HEAD BOLTS

$\frac{3}{8}$ " U.N.F. THREAD

Material: HIGH TENSILE STEEL (CADMIUM)

Details available on request

AS 7264 to AS 7308

LARGE ROUND HEAD BOLTS

$\frac{3}{8}$ " U.N.F. THREAD

Material: HIGH TENSILE STEEL (CADMIUM)

Details available on request

AS 8451

WIRE THREAD INSERTS

FOR U.N.F. THREADS

Material: SPRING STEEL (CADMIUM)

Details available on request

AS 8452

WIRE THREAD INSERTS

FOR U.N.C. THREADS

Material: SPRING STEEL (CADMIUM)

Details available on request

Brown Brothers Engineering Ltd

AS 8455

WIRE THREAD INSERTS

FOR U.N.F. THREADS

Material: NON-CORRODIBLE STEEL (CADMIUM)

Details available on request

AS 8456

WIRE THREAD INSERTS

FOR U.N.C. THREADS

Material: NON-CORRODIBLE STEEL (CADMIUM)

Details available on request

AS 8589

CONE UNION ADAPTOR

(UNIFIED ATTACHMENT END)

Material: STAINLESS STEEL (SELF)

Dimensionally as AS 6691

AS 8590

UNION ADAPTOR

(UNIFIED ATTACHMENT END)

Material: STAINLESS STEEL (SELF)

Dimensionally as AS 6692

AS 8591

CONE UNION ADAPTOR

(UNIFIED ATTACHMENT END)

Material: STAINLESS STEEL (SELF)

Dimensionally as AS 6693

Brown Brothers Engineering Ltd

AS 8592

UNION ADAPTOR (UNIFIED ATTACHMENT END)

Material: STAINLESS STEEL (SELF)
Dimensionally as AS 6694

AS 8595

DRAIN TRAP

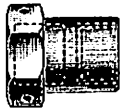

Material: ALUMINIUM ALLOY (ANODISED)
Across flats: 0.805"/0.813"
Threads: $\frac{3}{16}$ " \times 28 T.P.I. U.N.S.
Overall length: 0.825"

AS 8596

WASHER



Material: RUBBER
Outside diameter: $\frac{3}{16}$ "
Bore: $\frac{3}{8}$ "
Thickness: $\frac{1}{16}$ "

AS 8597

PITOT DRAIN

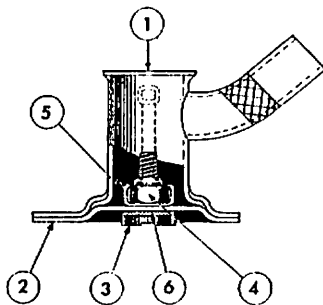

Material: ITEM 1, 2 and 5—TUNGUM & BRASS (CADMIUM)
ITEM 3—CORROSION RESISTANT STEEL (SELF)

ITEM	PART NO.	DESCRIPTION	ITEM	PART NO.	DESCRIPTION
1	AS 8598	Housing	4	A 125/D 66	Stiffnut—No. 10 UNF
2	AS 6614	Base	5	AS 6616	Anchor Clip
3	AS 6615	Special Bolt	6	AS 1186/3	Seal

AS 8599

UNION NUT



Material: ALUMINIUM ALLOY (ANODISED)
plus RUBBER BUSH
Across flats: 0.679"/0.688"
Threads: $\frac{3}{16}$ " \times 28 T.P.I. U.N.S.
Overall length: 0.440"

AS 8646

CHANNEL

For use with Nylastic clips AS 4580 and 4581
Details on application

Brown Brothers Engineering Ltd

AS 8662 PITOT & STATIC MANIFOLD CONNECTION

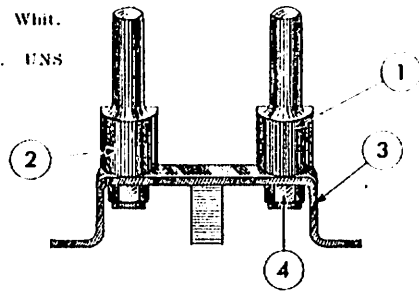
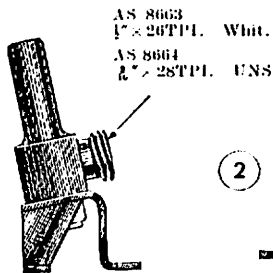

Material:
ALUMINIUM ALLOY
(ANODISED)

ITEM	PART No.	DESCRIPTION
1	AS 8663	Pitot connection
2	AS 8664	Static connection
3	AS 8665	Bracket
4	A 129/E	Stiffnut - 1" UNF

AS 8666 BALLAST WEIGHT

Material: LEAD—
5 LBS. WEIGHT

DIMENSIONS:
5.8" O/D × 1.19" I/D × .49" THICK

AS 8679 BANJO FITTINGS FOR PITOT/ STATIC SYSTEM

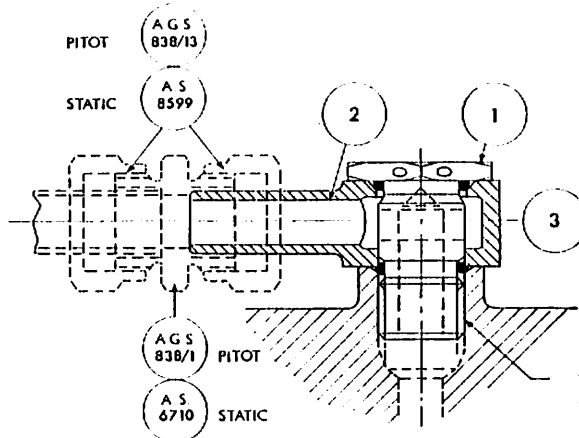

Material:
ALUMINIUM
ALLOY
(ANODISED)

AS 8682 $\frac{7}{16}$ " × 20 U.N.F.
AS 8683 $\frac{1}{2}$ " × 20 U.N.F.

ITEM	PART NUMBER		DESCRIPTION
	PITOT	STATIC	
1	AS 8682	AS 8683	Banjo Bolt
2	AS 8680	AS 8681	Banjo Body
3	AGS 3098	AGS 3099	"O" Ring Seal

AS 8690-8699 WASHER, CUP, LOCK

Material: CORROSION RESISTANT STEEL (SELF)
Details on request

Brown Brothers Engineering Ltd

AS 10700

ADAPTOR NIPPLE

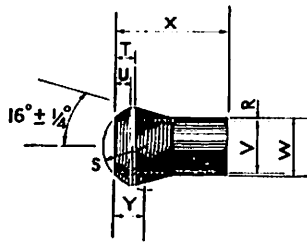

Material:
CORROSION RESISTING STEEL (SELF)

Working Pressure:

- 3,000 lb./sq. in. for sizes up to 1/2" B.S.P.
- 500 lb./sq. in. for sizes 5/8" to 1" B.S.P.
- 200 lb./sq. in. for sizes 1 1/4" to 2" B.S.P.
- 100 lb./sq. in. for size 2 1/2" B.S.P.

ITEM	O/D OF PIPE	Y	X	W	V	U	T	S	R
								RAD.	MIN.
A	1/8"	0.10"	0.70"	0.118"	5/32"	0.005"	0.105"	0.13"	0.016"
B	1/4"	0.14"	0.85"	0.181"	3/16"	0.070"	0.110"	0.20"	0.016"
BB	5/16"	0.17"	0.90"	0.227"	1/8"	0.070"	0.110"	0.24"	0.016"
C	3/8"	0.19"	0.95"	0.200"	1/4"	0.100"	0.140"	0.27"	0.017"
CC	7/16"	0.21"	1.00"	0.352"	5/16"	0.110"	0.150"	0.30"	0.017"
D	1/2"	0.22"	1.02"	0.415"	3/8"	0.115"	0.155"	0.33"	0.017"
E	5/8"	0.29"	1.07"	0.540"	1/2"	0.140"	0.180"	0.41"	0.017"
F	3/4"	0.30"	1.10"	0.665"	5/8"	0.175"	0.215"	0.46"	0.018"
G	7/8"	0.37"	1.15"	0.789"	3/4"	0.150"	0.190"	0.56"	0.018"
H	1"	0.36"	1.20"	0.914"	7/8"	0.160"	0.200"	0.61"	0.018"
J	1 1/4"	0.48"	1.30"	1.163"	1.100"	0.170"	0.210"	0.77"	0.025"
K	1 1/2"	0.55"	1.45"	1.412"	1.350"	0.190"	0.230"	0.91"	0.030"
M	2"	0.67"	2.00"	1.852"	1.780"	0.200"	0.250"	1.17"	0.035"
P	2 1/2"	0.83"	2.00"	2.302"	2.220"	0.200"	0.250"	1.51"	0.040"

Brown Brothers Engineering Ltd

AS 10701

NIPPLE

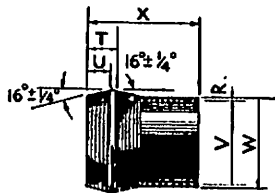

Material:
CORROSION RESISTING STEEL (SELF)

Working pressure:

3,000 lb./sq. in. for sizes 3/16" to 1/2" B.S.P.

500 lb./sq. in. for sizes 5/8" to 1" B.S.P.

200 lb./sq. in. for sizes 1 1/4" to 2" B.S.P.

100 lb./sq. in. for size 2 1/2" B.S.P.

ITEM	O/D. OF PIPE	X	W	V	U	T	R
							MIN.
A	3/16"	0.70"	0.118"	5/32"	0.142"	0.192"	0.016"
B	1/4"	0.85"	0.181"	3/8"	0.185"	0.235"	0.016"
BB	5/16"	0.90"	0.227"	3/16"	0.235"	0.285"	0.016"
C	3/8"	0.95"	0.290"	1/4"	0.235"	0.285"	0.017"
CC	7/16"	1.00"	0.352"	5/16"	0.235"	0.285"	0.017"
D	1/2"	1.02"	0.415"	3/8"	0.235"	0.285"	0.017"
E	5/8"	1.05"	0.540"	1/2"	0.235"	0.285"	0.017"
F	3/4"	1.11"	0.665"	5/8"	0.235"	0.285"	0.018"
G	7/8"	1.13"	0.789"	3/4"	0.235"	0.285"	0.018"
H	1"	1.16"	0.914"	7/8"	0.235"	0.285"	0.018"
J	1 1/4"	1.25"	1.163"	1.100"	0.235"	0.285"	0.025"
K	1 1/2"	1.45"	1.412"	1.350"	0.285"	0.335"	0.030"
M	2"	2.25"	1.852"	1.780"	0.425"	0.525"	0.035"
P	2 1/2"	2.45"	2.302"	2.220"	0.570"	0.670"	0.040"

Brown Brothers Engineering Ltd

AS 12800 & 12801

TORDIDAL SEALING RING

Material: FLUOROCARBON RUBBER
(NATURAL)

Details on application

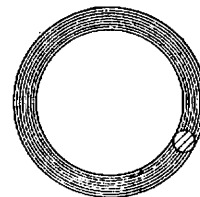

AS 12810-12839

SPRING CLIP-INNER

Material: SPRING STEEL (STOVE ENAMEL)

Details on application

AS 12840-12869

SPRING CLIP-OUTER

Material: SPRING STEEL (STOVE ENAMEL)

Details on application

AS 12870-12889

PLASTIC BUSHING

Material: P.T.F.E. (NATURAL)

For use with AS 12810-12869. Details on application

AS 12890-12939

PLASTIC BUSHING

Material: P.T.F.E. (NATURAL)

For use with AS 12810-12869. Details on application

AS 12940-12959

PRECISION COUNTERSUNK WASHERS

Materials: CORROSION RESISTING STEEL (SELF)

PART NO.	FASTENER DIA.	A	B	C
AS 12942	0.164"	0.160" 0.172"	0.375"	0.071"
AS 12943	0.190"	0.192" 0.200"	0.438"	0.080"
AS 12944	0.250"	0.252" 0.200"	0.625"	0.080"
AS 12945	0.312"	0.315" 0.324"	0.750"	0.100"
AS 12946	0.375"	0.378" 0.388"	0.875"	0.112"
AS 12947	0.437"	0.444" 0.451"	1.000"	0.125"
AS 12948	0.500"	0.504" 0.515"	1.188"	0.160"

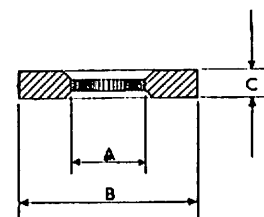
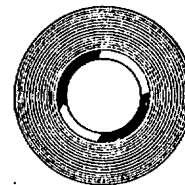

Brown Brothers Engineering Ltd

AS 13000-14199

**DOUBLE HEXAGON HEADED BOLT
EXTENDED WASHER FACE**

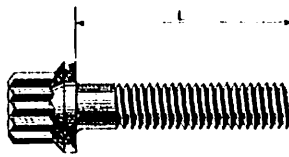

Material:
SEE TABLE (SELF)

THREAD SIZE	MATERIAL		
	DTD 5066	DTD 5026	DTD 5077
0-187" × 32 UNS	AS 13005 to AS 13062	AS 13405 to AS 13462	AS 13805 to AS 13862
0-247" × 28 UNS	AS 13106 to AS 13196	AS 13506 to AS 13596	AS 13906 to AS 13996
0-3095" × 24 UNS	AS 13207 to AS 13296	AS 13607 to AS 13696	AS 14007 to AS 14096
0-372" × 24 UNS	AS 13308 to AS 13396	AS 13708 to AS 13796	AS 14108 to AS 14196

METHOD OF ORDERING

Double hexagon headed bolts should be ordered by the appropriate part number from the above table, dependent on the thread and material, the last two digits representing the "L" length in $\frac{1}{8}$ of an inch.
EXAMPLE: A bolt in DTD 5066 0-187" × 32 UNS thread 0-812" long would be AS 13013.

AS 14500-15699

**DOUBLE HEXAGON HEADED BOLT
EXTERNALLY RELIEVED BODY. EXTENDED WASHER FACE**

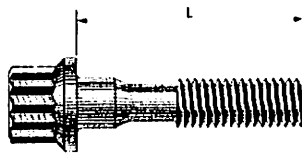
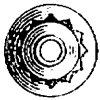

Material:
SEE TABLE (SELF)

THREAD SIZE	MATERIAL		
	DTD 5066	DTD 5026	DTD 5077
0-187" × 32 UNS	AS 14511 to AS 14562	AS 14911 to AS 14962	AS 15311 to AS 15362
0-247" × 28 UNS	AS 14612 to AS 14696	AS 15012 to AS 15096	AS 15412 to AS 15496
0-3095" × 24 UNS	AS 14713 to AS 14796	AS 15113 to AS 15196	AS 15513 to AS 15596
0-372" × 24 UNS	AS 14814 to AS 14896	AS 15214 to AS 15296	AS 15614 to AS 15696

METHOD OF ORDERING

Double hexagon headed bolts should be ordered by the appropriate part number from the above table, dependent on the thread and material, the last two digits representing the "L" length in $\frac{1}{8}$ of an inch.
EXAMPLE: A bolt in DTD 5066, 0-187" × 32 UNS thread 0-812" long would be AS 14513.

Brown Brothers Engineering Ltd

TYPICAL ASSEMBLIES OF PIPE JOINTS AS 15700 Series UNIFIED THREADS—STAINLESS STEEL

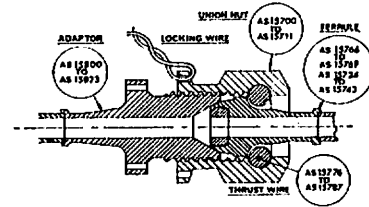
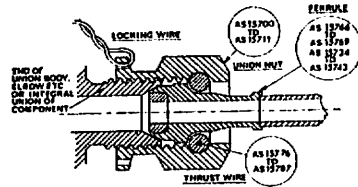

AS 15700-15711

UNION NUT

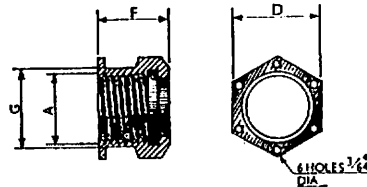

Material:
STAINLESS STEEL
(Silver Plate)

AS 15700—AS 15705: Manufactured from hex. bar.
AS 15706—AS 15711: Manufactured from round bar.

PART NO.	O/D. of Pipe	A THREAD	D A/F		F	G DIA.
			MIN.	MAX.		
AS 15700	$\frac{1}{8}$ "	$\frac{1}{8}$ " \times 20 UNJF	0.021"	0.025"	0.040"	0.515"
AS 15701	$\frac{1}{4}$ "	$\frac{1}{4}$ " \times 20 UNJF	0.083"	0.087"	0.040"	0.585"
AS 15702	$\frac{1}{2}$ "	$\frac{1}{2}$ " \times 18 UNJF	0.808"	0.812"	0.095"	0.720"
AS 15703	$\frac{3}{4}$ "	$\frac{3}{4}$ " \times 16 UNJS	0.871"	0.875"	0.095"	0.795"
AS 15704	$\frac{1}{2}$ "	$\frac{1}{2}$ " \times 16 UNJF	0.933"	0.937"	0.750"	0.865"
AS 15705	1"	$\frac{1}{2}$ " \times 16 UNJS	0.995"	1.000"	0.795"	0.935"
			DIA.			
AS 15706	1"	$\frac{1}{2}$ " \times 14 UNJF	1.246"	1.250"	0.925"	0.990"
AS 15707	$\frac{3}{4}$ "	$\frac{1}{2}$ " \times 12 UNJS	1.371"	1.375"	0.950"	1.175"
AS 15708	$\frac{1}{2}$ "	$\frac{1}{2}$ " \times 12 UNJS	1.496"	1.500"	1.000"	1.300"
AS 15709	1"	$\frac{1}{2}$ " \times 12 UNJS	1.621"	1.625"	1.050"	1.425"
AS 15710	$1\frac{1}{2}$ "	$\frac{1}{2}$ " \times 12 UNJS	1.996"	2.000"	1.095"	1.800"
AS 15711	$1\frac{1}{2}$ "	$\frac{1}{2}$ " \times 12 UNJS	2.245"	2.250"	1.200"	2.050"

Brown Brothers Engineering Ltd

AS 15724-15743

FERRULE

Material: STAINLESS STEEL (SELF)

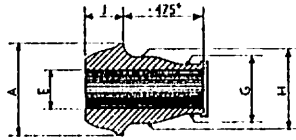

PART NO.	TUBE		A	E	G	H	J
	O/DIA.	S.W.G.					
AS 15724	1/8"	22	0-515"	0-250"	0-312"	0-385"	0-220"
AS 15725	1/8"	20	0-515"	0-234"	0-312"	0-385"	0-220"
AS 15726	3/8"	22	0-507"	0-312"	0-375"	0-445"	0-220"
AS 15727	3/8"	20	0-507"	0-297"	0-375"	0-445"	0-220"
AS 15728	7/8"	22	0-635"	0-375"	0-438"	0-510"	0-250"
AS 15729	7/8"	20	0-635"	0-359"	0-438"	0-510"	0-250"
AS 15730	1"	22	0-713"	0-438"	0-500"	0-575"	0-250"
AS 15731	1"	20	0-713"	0-422"	0-500"	0-575"	0-250"
AS 15732	1 1/8"	22	0-785"	0-502"	0-625"	0-690"	0-275"
AS 15733	1 1/8"	20	0-785"	0-547"	0-625"	0-680"	0-275"
AS 15734	1 3/8"	22	0-945"	0-688"	0-750"	0-835"	0-275"
AS 15735	1 3/8"	20	0-945"	0-672"	0-750"	0-835"	0-275"
AS 15736	1 1/2"	22	1-005"	0-812"	0-875"	0-935"	0-340"
AS 15737	1 1/2"	20	1-005"	0-797"	0-875"	0-935"	0-340"
AS 15738	1"	22	1-100"	0-937"	1-000"	1-035"	0-370"
AS 15739	1"	20	1-100"	0-922"	1-000"	1-035"	0-370"
AS 15740	1 1/4"	22	1-525"	1-100"	1-250"	1-345"	0-430"
AS 15741	1 1/4"	20	1-525"	1-175"	1-250"	1-345"	0-430"
AS 15742	1 1/2"	22	1-700"	1-440"	1-500"	1-590"	0-505"
AS 15743	1 1/2"	20	1-700"	1-425"	1-500"	1-590"	0-505"

Brown Brothers Engineering Ltd

AS 15766-15769

FERRULE

Material: STAINLESS STEEL (SELF)

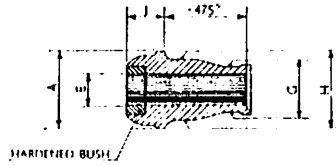

PART No.	TUBE		A	B	C	D	E
	O/DIA.	S.W.G.					
AS 15766	3/8"	22	0.375"	0.109"	0.188"	0.260"	0.185"
AS 15767	3/8"	20	0.375"	0.113"	0.188"	0.260"	0.185"
AS 15768	1/2"	22	0.437"	0.188"	0.250"	0.325"	0.220"
AS 15769	1/2"	20	0.437"	0.172"	0.250"	0.325"	0.220"

AS 15776-15787

THRUST WIRE

Material: CORROSION RESISTANT STEEL (SELF)

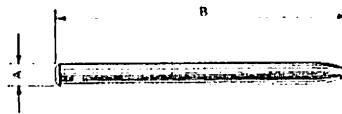

PART No.	TUBE O/D	NUT THREAD SIZE	A DIA.	B
AS 15776	3/8"	3/8" x 20 UNF	0.110"	1.250"
AS 15777	1/2"	1/2" x 20 UNF	0.110"	1.435"
AS 15778	3/8"	3/8" x 18 UNF	0.125"	1.680"
AS 15779	1/2"	1/2" x 16 UN	0.125"	1.875"
AS 15780	3/8"	3/8" x 16 UNF	0.125"	2.085"
AS 15781	1/2"	1/2" x 16 UN	0.125"	2.205"
AS 15782	3/8"	3/8" x 14 UNF	0.125"	2.640"
AS 15783	1/2"	1 1/8" x 12 UN	0.125"	3.080"
AS 15784	1/2"	1 1/8" x 12 UN	0.125"	3.430"
AS 15785	1"	1 1/8" x 12 UN	0.155"	3.820"
AS 15786	1 1/4"	1 1/8" x 12 UN	0.155"	4.930"
AS 15787	1 1/4"	1 1/8" x 12 UN	0.155"	5.630"

Brown Brothers Engineering Ltd

AS 15800-15823

ADAPTOR

Material: STAINLESS STEEL (SELF)

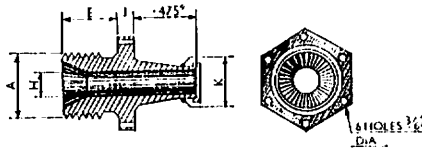

PART NO.	TUBE		A THREAD	B A/P		E	H	J	K DIA.
	O/DIA.	S.W.G.		MIS.	MAX.				
AS 15800	3/8"	22	3/8" x 20 UNF	0.559"	0.562"	0.440"	0.125"	0.120"	0.188"
AS 15801	3/8"	20	3/8" x 20 UNF	0.559"	0.562"	0.440"	0.109"	0.120"	0.188"
AS 15802	1/2"	22	1/2" x 20 UNF	0.621"	0.625"	0.440"	0.188"	0.120"	0.250"
AS 15803	1/2"	20	1/2" x 20 UNF	0.621"	0.625"	0.440"	0.172"	0.120"	0.250"
AS 15804	5/8"	22	5/8" x 18 UNF	0.683"	0.687"	0.490"	0.250"	0.140"	0.312"
AS 15805	5/8"	22	5/8" x 18 UNF	0.683"	0.687"	0.490"	0.234"	0.140"	0.312"
AS 15806	3/4"	22	3/4" x 16 UN	0.746"	0.750"	0.495"	0.312"	0.140"	0.375"
AS 15807	3/4"	20	3/4" x 16 UN	0.746"	0.750"	0.495"	0.297"	0.140"	0.375"
AS 15808	7/8"	22	7/8" x 16 UN	0.808"	0.812"	0.545"	0.375"	0.160"	0.438"
AS 15809	7/8"	20	7/8" x 16 UN	0.808"	0.812"	0.545"	0.350"	0.160"	0.438"
AS 15810	1"	22	1" x 16 UN	0.871"	0.875"	0.595"	0.438"	0.160"	0.500"
AS 15811	1"	20	1" x 16 UN	0.871"	0.875"	0.595"	0.422"	0.160"	0.500"
AS 15812	1 1/8"	22	1 1/8" x 14 UNF	0.933"	0.937"	0.680"	0.582"	0.180"	0.625"
AS 15813	1 1/8"	20	1 1/8" x 14 UNF	0.933"	0.937"	0.680"	0.547"	0.180"	0.625"
AS 15814	1 1/4"	22	1 1/4" x 12 UN	1.120"	1.125"	0.685"	0.688"	0.180"	0.750"
AS 15815	1 1/4"	20	1 1/4" x 12 UN	1.120"	1.125"	0.685"	0.672"	0.180"	0.750"
AS 15816	1 1/2"	22	1 1/2" x 12 UN	1.245"	1.250"	0.735"	0.812"	0.180"	0.875"
AS 15817	1 1/2"	20	1 1/2" x 12 UN	1.245"	1.250"	0.735"	0.797"	0.180"	0.875"
AS 15818	1"	22	1 1/2" x 12 UN	1.432"	1.437"	0.735"	0.938"	0.200"	1.000"
AS 15819	1"	20	1 1/2" x 12 UN	1.432"	1.437"	0.735"	0.922"	0.200"	1.000"
AS 15820	1 1/4"	22	1 1/4" x 12 UN	1.807"	1.812"	0.735"	1.190"	0.200"	1.250"
AS 15821	1 1/4"	20	1 1/4" x 12 UN	1.807"	1.812"	0.735"	1.175"	0.200"	1.250"
AS 15822	1 1/2"	22	1 1/2" x 12 UN	1.995"	2.000"	0.735"	1.440"	0.200"	1.500"
AS 15823	1 1/2"	20	1 1/2" x 12 UN	1.995"	2.000"	0.735"	1.425"	0.200"	1.500"

Brown Brothers Engineering Ltd

AS 15824-15835

NUT ASSEMBLY

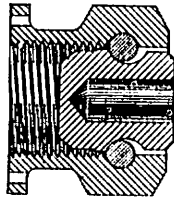

Material:
STAINLESS STEEL
(SILVER PLATE—NUT ONLY)

NOM. TUBE O/DIA.	ASSEMBLY NUMBER	COMPONENT PARTS		
		UNION NUT	THRUST WIRE	BLANK FERRULE
3/8"	AS 15824	AS 15700	AS 15776	AS 15838
1/2"	AS 15825	AS 15701	AS 15777	AS 15837
5/8"	AS 15826	AS 15702	AS 15778	AS 15838
1"	AS 15827	AS 15703	AS 15779	AS 15839
1 1/8"	AS 15828	AS 15704	AS 15780	AS 15840
1 1/4"	AS 15829	AS 15705	AS 15781	AS 15841
1 3/8"	AS 15830	AS 15706	AS 15782	AS 15842
1 1/2"	AS 15831	AS 15707	AS 15783	AS 15843
1 3/4"	AS 15832	AS 15708	AS 15784	AS 15844
2"	AS 15833	AS 15709	AS 15785	AS 15845
2 1/4"	AS 15834	AS 15710	AS 15786	AS 15846
2 1/2"	AS 15835	AS 15711	AS 15787	AS 15847

AS 15836-15847

BLANK FERRULE

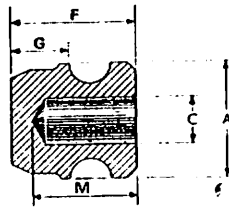

Material:
STAINLESS STEEL (SELF)

PART NO.	O/D OF PIPE	A	G	F	G	M
AS 15836	3/8"	0.375"	0.120"	0.440"	0.185"	0.340"
AS 15837	1/2"	0.437"	0.185"	0.475"	0.220"	0.375"
AS 15838	5/8"	0.515"	0.245"	0.495"	0.220"	0.395"
AS 15839	1"	0.567"	0.310"	0.495"	0.220"	0.395"
AS 15840	1 1/8"	0.635"	0.360"	0.525"	0.250"	0.425"
AS 15841	1 1/4"	0.713"	0.435"	0.525"	0.250"	0.425"
AS 15842	1 3/8"	0.785"	0.500"	0.585"	0.275"	0.485"
AS 15843	1 1/2"	0.845"	0.585"	0.585"	0.275"	0.485"
AS 15844	1 3/4"	1.005"	0.810"	0.660"	0.350"	0.560"
AS 15845	2"	1.190"	0.935"	0.730"	0.370"	0.630"
AS 15846	2 1/4"	1.525"	1.185"	0.790"	0.430"	0.690"
AS 15847	2 1/2"	1.760"	1.435"	0.865"	0.505"	0.765"

Brown Brothers Engineering Ltd

AS 16000-16399 SOLID RIVET—UNIVERSAL HEAD

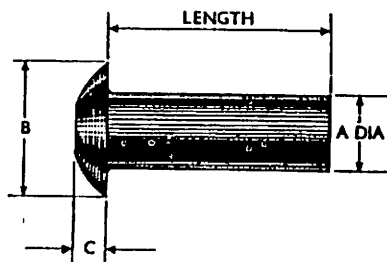

Material:

- AS 16000-16199 CORROSION RESISTING STEEL (SELF)
- AS 16200-16399 NIMONIC 75 (SELF)

BASIC PART NO.		NUM. DIA.	A	B	C	RANGE OF AVAILABLE LENGTHS
CORR. STL.	NIMONIC					
AS 16000	AS 16200	1/8"	0.081" 0.085"	0.125"	0.028"	4 m/m to 10 m/m
AS 16040	AS 16240	1/4"	0.093" 0.097"	0.188"	0.041"	4 m/m to 12 m/m
AS 16080	AS 16280	1/2"	0.124" 0.128"	0.250"	0.055"	4 m/m to 15 m/m
AS 16120	AS 16320	3/8"	0.155" 0.160"	0.313"	0.067"	6 m/m to 20 m/m
AS 16160	AS 16360	1/2"	0.186" 0.191"	0.375"	0.081"	8 m/m to 26 m/m

METHOD OF ORDERING

Universal headed rivets should be ordered by the basic part number dependent on the diameter and material, plus the shank length in millimetres. Example: a rivet 1/8" dia. in Nimonic 75 and 12 millimetres long would be AS 16292.

AS 16400-16799 SOLID RIVET—100° COUNTERSUNK HEAD

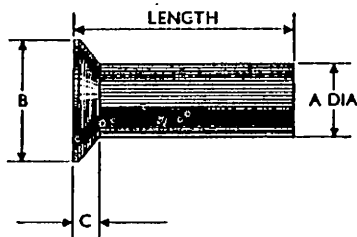

Material:

- AS 16400-16599 CORROSION RESISTING STEEL (SELF)
- AS 16600-16799 NIMONIC 75 (SELF)

BASIC PART NO.		NUM. DIA.	A	B	C	RANGE OF AVAILABLE LENGTHS
CORR. STL.	NIMONIC					
AS 16400	AS 16600	1/8"	0.081" 0.085"	0.110"	0.022"	4 m/m to 10 m/m
AS 16440	AS 16640	1/4"	0.093" 0.097"	0.170"	0.035"	4 m/m to 12 m/m
AS 16480	AS 16680	1/2"	0.124" 0.128"	0.210"	0.043"	4 m/m to 15 m/m
AS 16520	AS 16720	3/8"	0.155" 0.160"	0.270"	0.055"	6 m/m to 20 m/m
AS 16560	AS 16760	1/2"	0.186" 0.191"	0.330"	0.071"	8 m/m to 28 m/m

METHOD OF ORDERING

100° countersunk headed rivets should be ordered by the basic part number dependent on the diameter and material, plus the length in millimetres. Example: a rivet 1/8" dia. in Nimonic 75 and 8 millimetres long would be AS 16688.

Brown Brothers Engineering Ltd

AS 17000-18199

DOUBLE HEXAGON HEADED BOLT

EXTENDED WASHER FACE. CUPFACE LOCKED

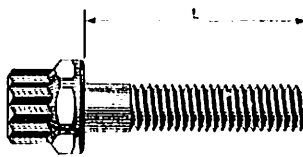

Material:

SEE TABLE (SELF)

THREAD SIZE	MATERIAL		
	DTD 5066	DTD 5026	DTD 5077
0-187" × 32 UNS	AS 17005 to AS 17062	AS 17405 to AS 17462	AS 17805 to AS 17862
0-247" × 28 UNS	AS 17106 to AS 17196	AS 17506 to AS 17596	AS 17906 to AS 17996
0-3095" × 24 UNS	AS 17207 to AS 17296	AS 17607 to AS 17696	AS 18007 to AS 18096
0-372" × 24 UNS	AS 17308 to AS 17396	AS 17708 to AS 17796	AS 18108 to AS 18196

METHOD OF ORDERING

Double hexagon headed bolts should be ordered by the appropriate part number from the above table, dependent on the thread and material, the last two digits representing the "L" length in $\frac{1}{16}$ of an inch.

EXAMPLE: A bolt in DTD 5066, 0-187" × 32 UNS thread 0-812" long would be AS 17013.

AS 18200-19399

DOUBLE HEXAGON HEADED BOLT

EXTERNALLY RELIEVED BODY. EXTENDED WASHER FACE. CUPWASHER LOCKED

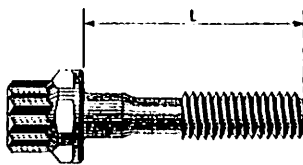

Material:

SEE TABLE (SELF)

THREAD SIZE	MATERIAL		
	DTD 5066	DTD 5026	DTD 5077
0-187" × 32 UNS	AS 18211 to AS 18262	AS 18611 to AS 18662	AS 19011 to AS 19062
0-247" × 28 UNS	AS 18312 to AS 18396	AS 18712 to AS 18796	AS 19112 to AS 19196
0-3095" × 24 UNS	AS 18413 to AS 18496	AS 18813 to AS 18896	AS 19213 to AS 19296
0-372" × 24 UNS	AS 18514 to AS 18596	AS 18914 to AS 18996	AS 19314 to AS 19396

Double hexagon headed bolts should be ordered by the appropriate part number from the above table, dependent on the thread and material, the last two digits representing the "L" length in $\frac{1}{16}$ of an inch.

EXAMPLE: A bolt in DTD 5066, 0-187" × 32 UNS thread 0-812" long would be AS 18213.

Brown Brothers Engineering Ltd

AS 20761-20765

RETAINING RINGS

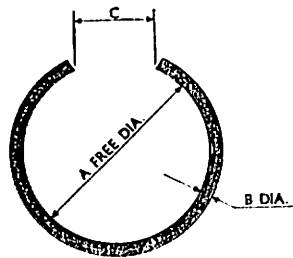

Material:

STAINLESS STEEL (SELF)

For use with AS 29640-20659

PART NUMBER	NOM. DIA.	A	B	C
AS 20761	4 mm.	0.136"	0.022"	0.065"
AS 20762	5 mm.	0.176"	0.022"	0.080"
AS 20763	6 mm.	0.215"	0.022"	0.100"
AS 20764	8 mm.	0.294"	0.022"	0.130"
AS 20765	10 mm.	0.367"	0.028"	0.160"

AS 20800-22299
AS 30200-30799

DOUBLE HEXAGON HEADED BOLT

EXTENDED WASHER FACE

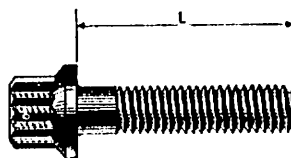

Material:

SEE TABLE (SELF)

THREAD SIZE	MATERIAL		
	DTD 5066	DYD 5026	DTD 5077
0.164" × 36 UNJF	AS 20804 to AS 20832	AS 21304 to AS 21332	AS 21804 to AS 21832
0.190" × 32 UNJF	AS 20905 to AS 20962	AS 21405 to AS 21462	AS 21905 to AS 21962
0.250" × 28 UNJF	AS 21006 to AS 21096	AS 21506 to AS 21596	AS 22006 to AS 22096
0.3125" × 24 UNJF	AS 21107 to AS 21196	AS 21607 to AS 21696	AS 22107 to AS 22196
0.375" × 24 UNJF	AS 21208 to AS 21296	AS 21708 to AS 21796	AS 22208 to AS 22296
0.4375" × 20 UNJF	AS 30210 to AS 30296	AS 30410 to AS 30496	AS 30610 to AS 30696
0.500" × 20 UNJF	AS 30312 to AS 30396	AS 30512 to AS 30596	AS 30712 to AS 30796

METHOD OF ORDERING

Double hexagon headed bolts should be ordered by the appropriate part number from the above table, dependent on the thread and material, the last two digits representing the "L" length in $\frac{1}{16}$ of an inch.

EXAMPLE: A bolt in DTD 5066, 0.190" × 32 UNJF thread 0.812" long would be AS 20913

Brown Brothers Engineering Ltd

AS 22400-23799
AS 30800-31399

DOUBLE HEXAGON HEADED BOLT
CLOSE TOLERANCE SHANK. EXTENDED WASHER FACE

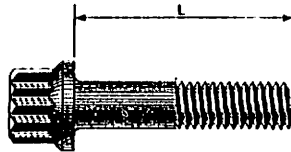

Material:
SEE TABLE (SELF)

THREAD SIZE	MATERIAL		
	DTD 5066	DTD 5026	DTD 5077
0-190" × 32 UNJF	AS 22409 to AS 22462	AS 22909 to AS 22962	AS 23409 to AS 23462
0-250" × 28 UNJF	AS 22511 to AS 22596	AS 23011 to AS 23096	AS 23511 to AS 23596
0-3125" × 24 UNJF	AS 22612 to AS 22696	AS 23112 to AS 23196	AS 23612 to AS 23696
0-375" × 24 UNJF	AS 22714 to AS 22796	AS 23214 to AS 23296	AS 23714 to AS 23796
0-4375" × 20 UNJF	AS 30816 to AS 30896	AS 31016 to AS 31096	AS 31216 to AS 31256
0-500" × 20 UNJF	AS 30918 to AS 30996	AS 31118 to AS 31196	AS 31318 to AS 31396

METHOD OF ORDERING

Double hexagon headed bolts should be ordered by the appropriate part number from the above table, dependent on the thread and material, the last two digits representing the "L" length in $\frac{1}{16}$ of an inch.

EXAMPLE: A bolt in DTD 5066, 0-190" × 32 UNJF thread 0-812" long would be AS 22413.

AS 23900-25296
AS 31400-31999

DOUBLE HEXAGON HEADED BOLT
EXTERNALLY RELIEVED BODY. EXTENDED WASHER FACE

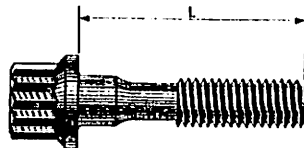

Material:
SEE TABLE (SELF)

THREAD SIZE	MATERIAL		
	DTD 5066	DTD 5026	DTD 5077
0-190" × 32 UNJF	AS 23911 to AS 23962	AS 24411 to AS 24462	AS 24911 to AS 24962
0-250" × 28 UNJF	AS 24012 to AS 24096	AS 24512 to AS 24596	AS 25012 to AS 25096
0-3125" × 24 UNJF	AS 24113 to AS 24196	AS 24613 to AS 24696	AS 25113 to AS 25196
0-375" × 24 UNJF	AS 24214 to AS 24296	AS 24714 to AS 24796	AS 25214 to AS 25296
0-4375" × 20 UNJF	AS 31415 to AS 31496	AS 31615 to AS 31696	AS 31815 to AS 31896
0-500" × 20 UNJF	AS 31515 to AS 31596	AS 31715 to AS 31796	AS 31915 to AS 31996

METHOD OF ORDERING

Double hexagon headed bolts should be ordered by the appropriate part number from the above table, dependent on the thread and material, the last two digits representing the "L" length on $\frac{1}{16}$ of an inch.

EXAMPLE: A bolt in DTD 5066, 0-190" × 32 UNJF thread 0-812" long would be AS 23913.

Brown Brothers Engineering Ltd

AS 26100-27299
AS 28100-28699

DEE HEADED BOLT

CLOSE TOLERANCE SHANK

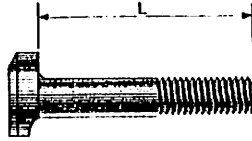
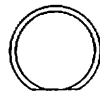

Material:
SEE TABLE (SELF)

Bolts in material specification DTD 5026 have a larger head than shown

THREAD SIZE	MATERIAL		
	DTD 5066	DTD 5026	DTD 5077
0.190" x 32 UNJF	AS 26109 to AS 26162	AS 28109 to AS 28162	AS 26709 to AS 26762
0.250" x 28 UNJF	AS 26211 to AS 26266	AS 28211 to AS 28266	AS 26811 to AS 26866
0.3125" x 24 UNJF	AS 26312 to AS 26368	AS 28312 to AS 28368	AS 26912 to AS 26968
0.375" x 24 UNJF	AS 26414 to AS 26468	AS 28414 to AS 28468	AS 27014 to AS 27068
0.4375" x 20 UNJF	AS 26516 to AS 26568	AS 28516 to AS 28568	AS 27116 to AS 27168
0.500" x 20 UNJF	AS 26618 to AS 26668	AS 28618 to AS 28668	AS 27218 to AS 27268

METHOD OF ORDERING

Dee headed bolts should be ordered by the appropriate part number from the above table, dependent on the thread and material, the last two digits representing the "L" length in $\frac{1}{16}$ of an inch.
EXAMPLE: A bolt in DTD 5066, 0.190" x 32 UNJF thread 0.812" long would be AS 26113.

AS 28950-28959

'P' SECTION RUBBER

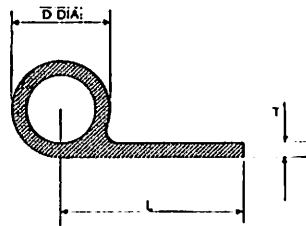

ITEM	D	L	T
1	0.15"	0.70"	0.04"
2	0.25"	0.75"	0.06"
3	0.35"	0.80"	0.06"
4	0.45"	0.85"	0.06"
5	0.55"	0.90"	0.06"
6	0.65"	0.95"	0.06"
7	0.75"	1.00"	0.06"

PART No.	MATERIAL	SPECIFICATION	RELATIVE COSTS
AS 28950	Natural Rubber	BS 1154 Group Z	Low
AS 28951	Natural Rubber	BS 1155 Group T	Low
AS 28952	Neoprene	DTD 5514	Low
AS 28953	Silicone	DTD 5531	High
AS 28954	Viton	DTD 5543	High
AS 28955	Fluorosilicones	DTD 5583	Very High
AS 28956	Nitrile	DTD 5594	Low
AS 28957	Nitrile	DTD 5595	Low
AS 28958	Ethylenepropylene	DTD 5596	Moderate
AS 28959	Ethylenepropylene	DTD 5597	Moderate

METHOD OF ORDERING

Section to specification DTD 5596 Grade "C" and to the dimension for Item 4 in upper table would be AS 28958-4/55 (/55 being the hardness in ° I.R.H.).

Oddie

NUTS AND ANCHORAGES

MAXIMUM FASTENING EFFICIENCY
without auxiliary locking devices

- **Dispenses with the need for :—**
Drilled Bolt, Slotted Nut and Split Pin, Flat, Spring or Tab Washers. Double Lock Nuts. Peening or Rivetting over of bolt.
- **Provides all the features desired in a nut :—**
Ability to remain steadfast on the bolt without the aid of auxiliary locking devices. Completely unaffected by vibration, heat or oil. Precision one-piece construction, face square with thread. Easily and quickly fitted by hand or power—just as easily adjusted or removed. Can be used over and over again without impairing efficiency.
- *Available in ferrous and non-ferrous metals or with Special Anchorages as shown in the following pages.*

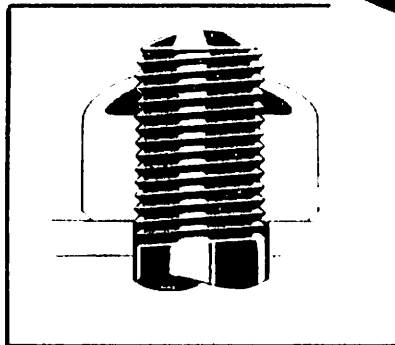
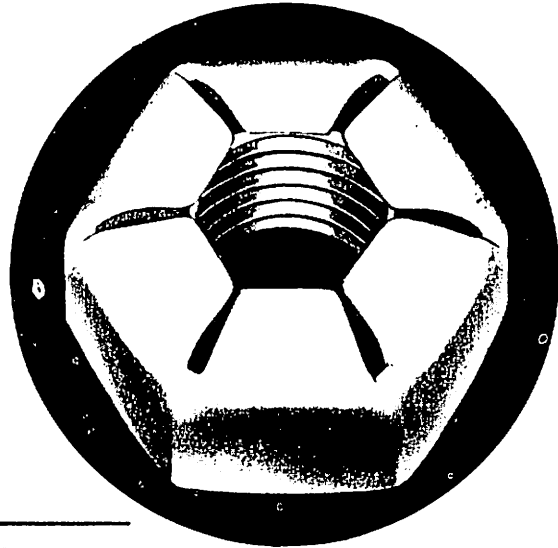

Patent Nos.
513344 and 551214

MINISTRY APPROVED

PAGES 255 TO 264

Brown Brothers Engineering Ltd

AGS 2001, 2002 & 2003

ODDIE AIRCRAFT HEXAGON NUTS BA & BSF THREADS

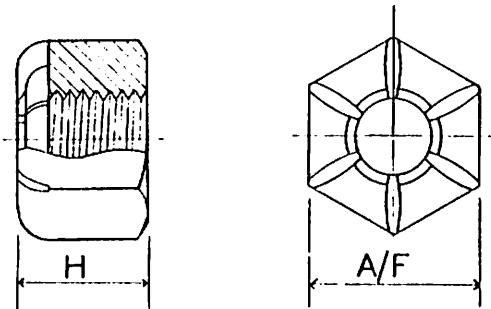

AGS 2001 THICK
AGS 2002 THIN
AGS 2003 COUNTERSUNK

PRINCIPAL DIMENSIONS

SUFFIX LETTER	THREAD SIZE	ACROSS FLATS		H	
		MIN.	MAX.	THICK AND COUNTERSUNK	THIN
A	6 BA	IN. 0.190	IN. 0.193	IN. 0.170	IN. 0.130
B	4 BA	0.245	0.248	0.190	0.150
C	2 BA	0.321	0.324	0.250	0.190
E	1/4" BSF	0.440	0.445	0.300	0.230
G	5/16" BSF	0.520	0.525	0.380	0.310
J	3/8" BSF	0.595	0.600	0.450	0.340
L	7/16" BSF	0.705	0.710	0.510	0.390
N	1/2" BSF	0.815	0.820	0.580	0.450
Q	5/8" BSF	1.002	1.010	0.750	0.570
S	3/4" BSF	1.192	1.200	0.900	0.670

SUFFIX NUMBER	MATERIAL	FINISH
1	Mild Steel	Cadmium
2	Non-corrodible Steel	Cadmium
3	Light Alloy	Anodised and Dyed Blue
4	Brass or Bronze	Electro-Tinned

METHOD OF ORDERING

Oddie aircraft hexagon nuts are ordered by the part number for the type required, followed by the suffix letter indicating the thread, followed by the suffix number indicating the material, i.e. the complete part number for a 2BA thick hexagon nut in mild steel is AGS 2001/C/1 and for 5/16" BSF countersunk nut in light alloy AGS 2003/G/3.

To ensure maximum locking it is recommended that a minimum of 2 threads protrude when nut is screwed on bolt.

Brown Brothers Engineering Ltd

AGS 2004, 2005 & 2006

ODDIE AIRCRAFT SINGLE ANCHOR NUTS (Single Rivet Fixing) BA & BSF THREADS

AGS 2004 THICK
AGS 2005 THIN
AGS 2006 COUNTERSUNK

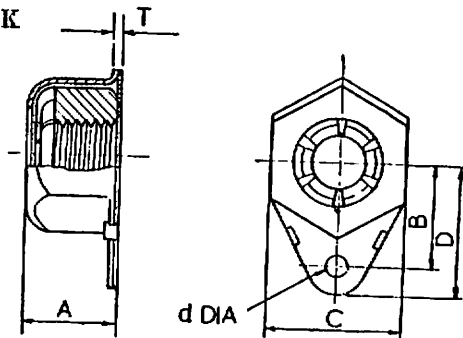

PRINCIPAL DIMENSIONS

SUFFIX LETTER	THREAD	A		B	C	D MAX.	T	d
		THICK & COUNTERSUNK	THIN					
A	0 BA	IN. 0.224	IN. 0.184	IN. 0.250	IN. 0.254	IN. 0.350	IN. 0.044	IN. 0.065
B	4 BA	0.260	0.227	0.350	0.315	0.470	0.044	0.096
C	2 BA	0.319	0.253	0.350	0.390	0.475	0.044	0.096
E	1" BSF	0.364	0.299	0.500	0.511	0.660	0.044	0.096
G	5/16" BSF	0.419	0.339	0.550	0.591	0.710	0.044	0.128
J	3/8" BSF	0.499	0.389	0.550	0.682	0.710	0.044	0.128
L	7/16" BSF	0.572	0.447	0.625	0.792	0.825	0.052	0.128
N	1" BSF	0.637	0.502	0.700	0.902	0.900	0.052	0.128

SUFFIX NUMBER	MATERIAL.	FINISH
1	Mild Steel	Cadmium
2	Non-corrodible Steel	Cadmium
3	Light Alloy	Anodised and Dyed Blue

METHOD OF ORDERING

Single anchor nuts (single fixing) are ordered by the part number for the type required, followed by the suffix letter indicating the thread, followed by the suffix number indicating the material, i.e. the complete part number for a 2BA thick single anchor nut in mild steel is AGS 2004/C/1 and for a 5/16" BSF countersunk single anchor nut in light alloy AGS 2006/G/3.

Brown Brothers Engineering Ltd

AGS 2007, 2008 & 2009

ODDIE AIRCRAFT DOUBLE ANCHOR NUTS BA & BSF THREADS

AGS 2007 THICK
AGS 2008 THIN
AGS 2009 COUNTERSUNK

SUFFIX	THREAD	PRINCIPAL DIMENSIONS						
		A		B	C	D MAX.	T	d
		THICK AND COUNTERSUNK	THIN					
A	6 BA	IN. 0.224	IN. 0.184	IN. 0.500	IN. 0.254	IN. 0.700	IN. 0.044	IN. 0.065
B	4 BA	0.269	0.227	0.700	0.315	0.910	0.014	0.096
C	2 BA	0.319	0.253	0.700	0.390	0.950	0.044	0.096
E	1" BSF	0.408	0.343	1.000	0.527	1.320	0.052	0.096
G	5/8" BSF	0.419	0.339	1.100	0.591	1.420	0.044	0.128
J	1" BSF	0.499	0.359	1.100	0.682	1.420	0.044	0.128
L	5/8" BSF	0.572	0.417	1.250	0.792	1.650	0.052	0.128
N	1" BSF	0.637	0.502	1.400	0.902	1.800	0.052	0.128

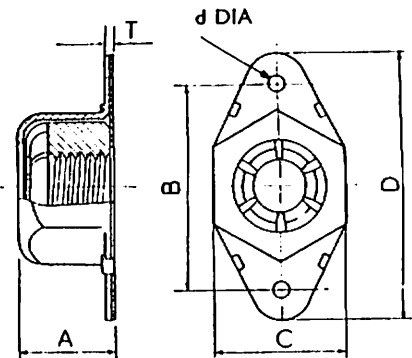

SUFFIX NUMBER	MATERIAL	FINISH
1	Mild Steel	Cadmium
2	Non-corrodible Steel	Cadmium
3	Light Alloy	Anodised and Dyed Blue

METHOD OF ORDERING

Double anchor nuts are ordered by the part number for the type required, followed by the suffix letter indicating the thread, followed by the suffix number indicating the material, i.e. the complete part number for a 2BA thick double anchor nut in mild steel is AGS 2007/C/1 and for a 5/8" BSF counter-sunk double anchor nut in light alloy AGS 2009/G/3.

AGS 2011

ODDIE AIRCRAFT CLINCH NUTS BA & BSF THREADS

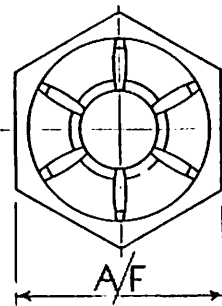
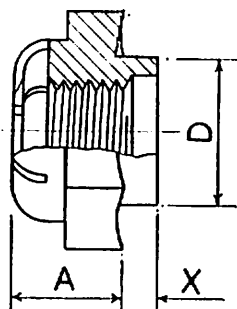

SUFFIX LETTER	THREAD SIZE	PRINCIPAL DIMENSIONS				MAX. S.W.G.	
		A. MAX.	ACROSS FLATS		D MAX. X MAX.		
A	6 BA	IN. 0.180	IN. 0.218	IN. 0.215	IN. 0.192	IN. 0.080	18
B	4 BA	0.218	0.324	0.321	0.255	0.085	18
C	2 BA	0.267	0.413	0.410	0.312	0.095	18
E	1" BSF	0.319	0.525	0.520	0.375	0.110	16
G	5/8" BSF	0.380	0.600	0.595	0.444	0.135	14
J	1" BSF	0.490	0.710	0.705	0.625	0.160	12

SUFFIX NUMBER	MATERIAL	FINISH
1	Mild Steel	Cadmium
2	Non-corrodible Steel	Cadmium
3	Aluminium Alloy	Anodised and Dyed Blue
4	Brass or Bronze	Electro-tinned

METHOD OF ORDERING

Clinch nuts are ordered by the part number, followed by the suffix letter indicating the size of thread, followed by the suffix number indicating the material, followed by the gauge of material in which the nut is to be used, i.e., the complete part number for a 2BA clinch nut in mild steel for use in a 20 SWG plate is AGS 2011/C/1/20 and a 5/8" BSF clinch nut in light alloy for use in a 16 S.W.G. plate is AGS 2011/G/3/16.

Brown Brothers Engineering Ltd

AGS 2012, 2013 & 2014 ODDIE AIRCRAFT FLOATING ANCHOR NUTS BA & BSF THREADS

AGS 2012 THICK
AGS 2013 THIN
AGS 2014 COUNTERSUNK

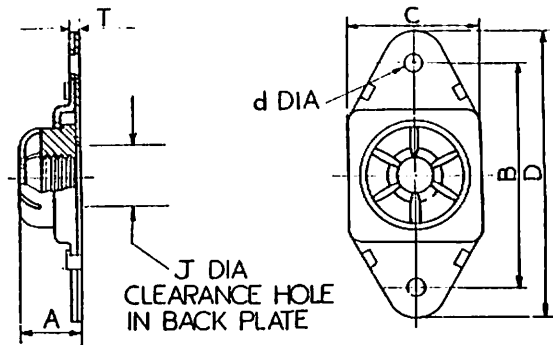

PRINCIPAL DIMENSIONS

SUFFIX LETTER	THREAD SIZE	A		B	C	D	J	T	d
		THICK & COUNTER-SUNK	THIN						
A	6 BA	IN. 0.200	IN. 0.200	IN. 0.500	IN. 0.432	IN. 0.700	IN. 0.140	IN. 0.044	IN. 0.065
B	4 BA	0.205	0.205	0.700	0.442	0.940	0.252	0.044	0.096
C	2 BA	0.269	0.269	0.700	0.561	0.940	0.313	0.044	0.096
E	1/4" BSF	0.330	0.263	1.000	0.643	1.312	0.408	0.052	0.096
G	5/16" BSF	0.473	0.390	1.100	1.020	1.420	0.360	0.052	0.128
J	3/8" BSF	0.490	0.450	1.200	1.115	1.562	0.420	0.052	0.128

MATERIAL FOR ATTACHMENT PLATE

SUFFIX NUMBER	MATERIAL	FINISH
1	Mild Steel	Cadmium
3	Light Alloy	Anodised and Dyed Blue

MATERIAL FOR NUT

SUFFIX NUMBER	MATERIAL	FINISH
1	Mild Steel	Cadmium
2	Non-corrodible Steel or Monel	Cadmium
3	Light Alloy	Anodised and Dyed Blue

METHOD OF ORDERING

Floating anchor nuts are ordered by the part number for the type required, followed by the suffix letter indicating the size of thread, followed by the suffix number indicating the material of the attachment plate followed by the suffix number indicating the material of the nut, i.e. the complete part number for a 2BA thick floating anchor nut with a mild steel base plate and mild steel nut is AGS 2012/C/11 and for a 1/16" BSF countersunk floating anchor nut with a mild steel base plate and a light alloy nut is AGS 2014/G/13.

Brown Brothers Engineering Ltd

AGS 2018, 2019 & 2020 ODDIE SINGLE ANCHOR NUTS (Double Rivet Fixing) BA & BSF THREADS

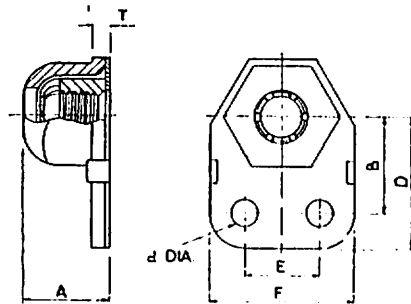

AGS 2018 THICK
AGS 2019 THIN
AGS 2020 COUNTERSUNK

PRINCIPAL DIMENSIONS

SUFFIX LETTER	THREAD	A		B	D	E	F MAX.	T	d
		THICK & COUNTER-SUNK	THIN						
A	6 BA	IN. 0.224	IN. 0.184	IN. 0.250	IN. 0.340	IN. 0.190	IN. 0.370	IN. 0.044	IN. 0.065
B	4 BA	0.269	0.227	0.350	0.470	0.250	0.490	0.044	0.096
C	2 BA	0.319	0.253	0.350	0.470	0.300	0.540	0.044	0.096
E	1/4" BSF	0.364	0.299	0.500	0.620	0.480	0.720	0.044	0.096
G	5/16" BSF	0.419	0.339	0.550	0.675	0.570	0.820	0.044	0.128
J	3/8" BSF	0.499	0.389	0.550	0.675	0.660	0.910	0.044	0.128
L	1/2" BSF	0.572	0.447	0.625	0.800	0.700	1.050	0.052	0.128
N	3/4" BSF	0.637	0.502	0.700	0.875	0.840	1.190	0.052	0.128

SUFFIX NUMBER	MATERIAL	FINISH
1	Mild Steel	Cadmium
2	Non-corrodible Steel	Cadmium
3	Light Alloy	Anodised and Dyed Blue

METHOD OF ORDERING

Single anchor nuts (double rivet fixing) are ordered by the part number for the type required, followed by the suffix letter indicating the thread, followed by the suffix number indicating the material, i.e. the complete part number for a 2BA single anchor nut in mild steel is AGS 2018/C/1 and for a 5/16" BSF countersunk single anchor nut in light alloy AGS 2020/G/3.

Brown Brothers Engineering Ltd

B.S. A122 to A124 UNIFIED CLINCH NUTS

Material:

- A122 STEEL (CADMIUM)
- A123 BRASS or BRONZE (ELECTRO TINNED)
- A124 ALUMINIUM ALLOY (ANODISED)

PART No.	TEMPERATURE RANGE
A122	-75°C. to +200°C.
A123	-75°C. to +125°C.
A124	-75°C. to +125°C.

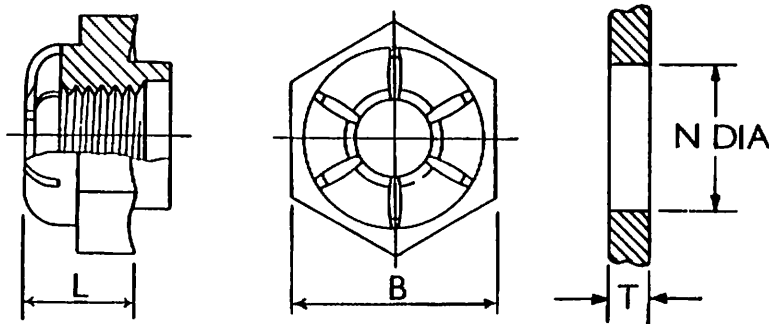

ITEM	THREAD SIZE	B A/F		L	N DIA.	SPIGOT LENGTHS TO SUIT 'T' THICKNESS PLATES.					
		MAX.	MIN.			GROUP 1		GROUP 2		GROUP 3	
				MAX.	NOM.	MAX.	MIN.	MAX.	MIN.	MAX.	MIN.
A	No. 4 × 40 UNC	0.250"	0.245"	0.145"	0.192"	19 S.W.G.	22 S.W.G.	16 S.W.G.	18 S.W.G.	—	—
B	No. 6 × 32 UNC	0.312"	0.307"	0.185"	0.254"	19 S.W.G.	22 S.W.G.	16 S.W.G.	18 S.W.G.	—	—
C	No. 8 × 32 UNC	0.344"	0.339"	0.233"	0.285"	17 S.W.G.	21 S.W.G.	14 S.W.G.	16 S.W.G.	10 S.W.G.	12 S.W.G.
D	No. 10 × 32 UNF	0.438"	0.431"	0.241"	0.316"	17 S.W.G.	21 S.W.G.	14 S.W.G.	16 S.W.G.	10 S.W.G.	12 S.W.G.
E	1/4" UNF	0.500"	0.493"	0.273"	0.379"	15 S.W.G.	18 S.W.G.	12 S.W.G.	14 S.W.G.	8 S.W.G.	10 S.W.G.
G	1/8" UNF	0.562"	0.554"	0.326"	0.442"	13 S.W.G.	16 S.W.G.	10 S.W.G.	12 S.W.G.	6 S.W.G.	8 S.W.G.
J	1" UNF	0.688"	0.679"	0.386"	0.560"	11 S.W.G.	13 S.W.G.	8 S.W.G.	10 S.W.G.	6 S.W.G.	7 S.W.G.

METHOD OF ORDERING:

All nuts are ordered by the British Standard Number, followed by the item letter for the size of the thread required, followed by the number representing the group providing the spigot length required.

When it is necessary to differentiate between clinch nuts with metallic or non-metallic friction elements, the suffix /66 for metallic or /77 for non-metallic friction element should be added to the part number.

Brown Brothers Engineering Ltd

BRITISH STANDARD UNIFIED AIRCRAFT STIFFNUTS STIFF NUT TYPES, PART NUMBERS, MATERIALS AND TEMPERATURE CLASSIFICATION

STIFF NUT TYPES		TEMPERATURE CLASSIFICATION				
		- 75° C. TO + 200° C.	- 75° C. TO + 200° C.	- 75° C. TO + 425° C.	- 75° C. TO + 125° C.	- 75° C. TO + 125° C.
		BRITISH STANDARD NUMBERS				
		STEEL NUTS CADMIUM PLATED	CORROSION-RESISTING STEEL NUTS		ALUMINIUM ALLOY NUTS ANODISED AND DYED BLUE	BRASS OR BRONZE NUTS TINNED
			CADMIUM PLATED	SILVER PLATED		
HEXAGON	Ordinary	2A125	2A127	2A180	2A129	2A131
	Thin	2A126	2A128	2A181	2A130	2A132
	Cap	A213	---	---	A214	---
DOUBLE-LUG FIXED ANCHOR	Ordinary	2A136	2A138	2A186	2A140	2A142
	Thin	2A137	2A139	2A187	2A141	2A143
	Cap	A215	---	---	A216	---
DOUBLE-LUG	WITH STEEL ATTACHMENT PLATE	Ordinary	2A117	---	---	---
	Thin	2A118	---	---	---	---
FLOATING	WITH CORROSION RESISTING STEEL ATTACHMENT PLATE	Ordinary	---	2A149	2A192	---
	Thin	---	2A150	2A193	---	---
ANCHOR	WITH ALUMINIUM ALLOY ATTACHMENT PLATE	Ordinary	2A151	---	2A153	---
	Thin	2A152	---	---	2A154	---
ANCHOR	WITH BRASS ATTACHMENT PLATE	Ordinary	---	---	---	2A155
	Thin	---	---	---	---	2A156
SINGLE-LUG FIXED ANCHOR	Ordinary	2A157	2A159	2A200	2A161	2A163
	Thin	2A158	2A160	2A201	2A162	2A164
STRIP	Ordinary	2A165	---	---	2A167	---
	Thin	2A166	---	---	2A168	---

METHOD OF ORDERING

When it is necessary to differentiate between metallic and non-metallic nuts in the steel and corrosion-resisting steel (-75°C. to $+200^{\circ}\text{C.}$) ranges, the suffix /66 for metallic or /77 for non-metallic should be added to the part number, i.e. a $\frac{1}{4}$ " UNF metallic ordinary hexagon nut should be ordered as A125/E/66.

When corrosion-resisting steel nuts in the -75°C. to $+425^{\circ}\text{C.}$ range are required self-finish, /UP should be added to the part number, i.e. a standard $\frac{1}{4}$ " UNF corrosion-resisting steel ordinary hexagon nut for temperature range -75°C. to $+425^{\circ}\text{C.}$ silver-plated should be ordered as A180/E, but if required self-finish should be ordered as A180/E/UP.

All nuts are ordered by the British Standard Number, followed by the part reference letter indicating the thread required.

For Part Reference numbers and Principle Dimensions see pages 263 and 264

**UNIFIED ODDIE STIFFNUTS
PART REFERENCES AND PRINCIPAL DIMENSIONS FOR
HEXAGON ORDINARY AND THIN NUTS**

FOR PART NUMBERS
SEE PAGE 262

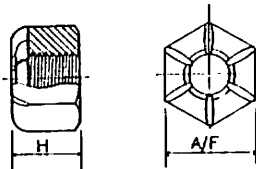

PART REF.	THREAD	ACROSS FLATS		H	
		MIN.	MAX.	ORDINARY	THIN
A	No. 4-40 UNG	IN. 0.183	IN. 0.189	IN. 0.175	IN. 0.143
B	No. 6-32 UNG	0.215	0.250	0.215	0.179
C	No. 8-32 UNG	0.307	0.312	0.275	0.233
D	No. 10-32 UNF	0.339	0.344	0.285	0.241
E	1/2" UNF	0.431	0.438	0.340	0.273
G	3/8" UNF	0.493	0.500	0.410	0.326
J	1/2" UNF	0.554	0.562	0.490	0.386
L	1/4" UNF	0.679	0.688	0.570	0.445
N	1" UNF	0.741	0.750	0.660	0.514
P	1/2" UNF	0.866	0.875	0.725	0.558
Q	1/2" UNF	0.929	0.938	0.810	0.623
S	1/2" UNF	1.052	1.062	0.975	0.746
U	1/2" UNF	1.240	1.250	1.085	0.835
W	1" UNF	1.426	1.428	1.245	0.953

**PART REFERENCES AND PRINCIPAL DIMENSIONS FOR ORDINARY
AND THIN DOUBLE LUG FIXED ANCHOR NUTS**

FOR PART NUMBERS
SEE PAGE 262

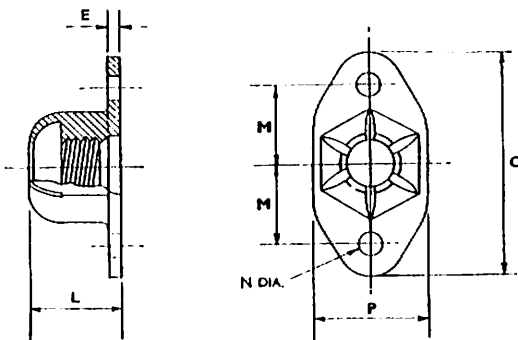

PART REF.	THREAD	I. MAX.		M	N	O MAX.	P MAX.	E MAX.
		ORDINARY	THIN					
A	No. 4-40 UNG	IN. 0.233	IN. 0.201	IN. 0.220	IN. 0.085	IN. 0.613	IN. 0.220	IN. 0.058
B	No. 6-32 UNG	0.273	0.237	0.250	0.065	0.673	0.290	0.058
C	No. 8-32 UNG	0.333	0.291	0.300	0.096	0.843	0.360	0.058
D	No. 10-32 UNF	0.343	0.299	0.325	0.096	0.893	0.390	0.068
E	1/2" UNF	0.398	0.331	0.375	0.090	0.993	0.505	0.058
G	3/8" UNF	0.468	0.384	0.425	0.128	1.163	0.577	0.058
J	1/2" UNF	0.548	0.444	0.475	0.128	1.263	0.650	0.058
L	1/4" UNF	0.628	0.503	0.550	0.128	1.413	0.794	0.058
N	1" UNF	0.718	0.572	0.600	0.128	1.513	0.866	0.058

**UNIFIED ODDIE STIFFNUTS
PART REFERENCES AND PRINCIPAL DIMENSIONS FOR ORDINARY
AND THIN DOUBLE-LUG FLOATING ANCHOR NUTS**

FOR PART NUMBERS
SEE PAGE 262

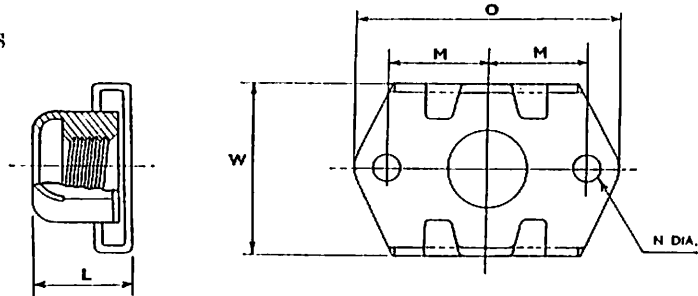

PRINCIPAL DIMENSIONS

PART REF.	THREAD	L MAX.		W MAX.	M	N	O MAX.
		ORDINARY	THIN				
B	No. 6-32 UNC	IN. 0.285	IN. 0.249	IN. 0.424	IN. 0.260	IN. 0.065	IN. 0.673
C	No. 8-32 UNC	0.353	0.311	0.496	0.300	0.096	0.813
D	No. 10-32 UNF	0.363	0.319	0.532	0.325	0.096	0.893
E	1" UNF	0.419	0.352	0.610	0.375	0.096	0.993
G	1.5" UNF	0.497	0.413	0.720	0.425	0.128	1.163
J	2" UNF	0.577	0.473	0.780	0.475	0.128	1.263

**PART REFERENCES AND PRINCIPAL DIMENSIONS FOR ORDINARY
AND THIN SINGLE-LUG FIXED ANCHOR NUTS**

FOR PART NUMBERS
SEE PAGE 262

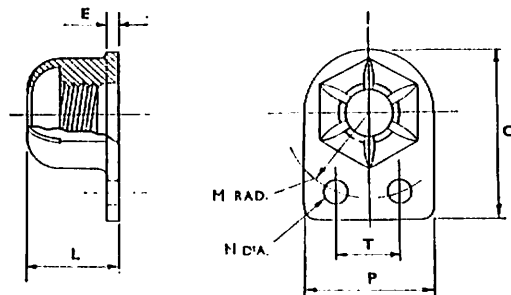

PRINCIPAL DIMENSIONS

PART REF.	THREAD	L MAX.		M	N	T	O MAX.	P MAX.	R MAX.
		ORDINARY	THIN						
A	No. 4-40 UNC	IN. 0.233	IN. 0.201	IN. 0.220	IN. 0.065	IN. 0.140	IN. 0.422	IN. 0.313	IN. 0.058
B	No. 6-32 UNC	0.237	0.273	0.250	0.065	0.160	0.491	0.333	0.058
C	No. 8-32 UNC	0.333	0.291	0.300	0.096	0.180	0.614	0.433	0.068
D	No. 10-32 UNF	0.343	0.299	0.325	0.096	0.215	0.653	0.458	0.068
E	1" UNF	0.398	0.331	0.375	0.096	0.300	0.740	0.510	0.068
G	1.5" UNF	0.468	0.384	0.425	0.128	0.310	0.865	0.620	0.068
J	2" UNF	0.572	0.468	0.475	0.128	0.380	0.910	0.690	0.082
L	2.5" UNF	0.652	0.527	0.550	0.128	0.530	1.060	0.810	0.082
N	3" UNF	0.742	0.596	0.600	0.128	0.610	1.135	0.920	0.082

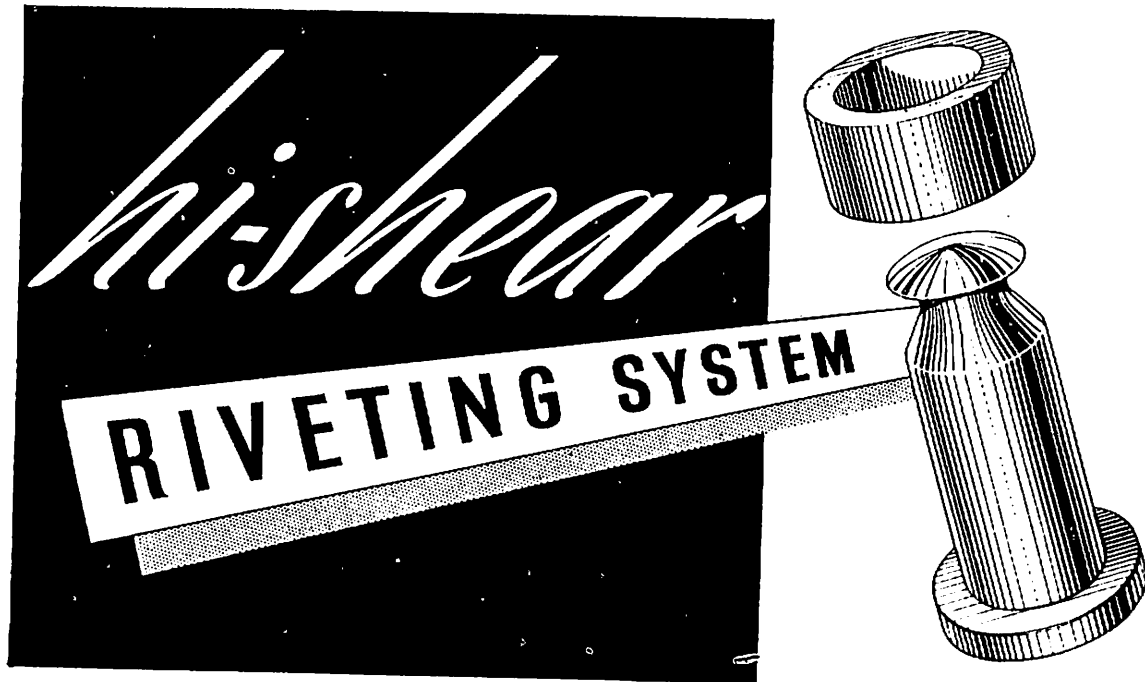

HI-SHEAR, proved and extensively used in this country and in the U.S.A., is a method of attachment designed to replace normal rivets and shear bolts. Joints made with HI-SHEAR effect an appreciable saving in space, weight and time of assembly over the older methods.

Exhaustive tests both here and in the U.S.A. show that HI-SHEAR PINS have a shear value equal to that of bolts in the same material and a tensile strength approximately 60 per cent. of the shear strength.

The accuracy of the heads on HI-SHEAR Countersunk Pins, coupled with the fact that fewer HI-SHEAR are required than normal rivets, enables maximum surface smoothness to be obtained.

HI-SHEAR are available in High Tensile, Stainless Steel and other materials that cannot be satisfactorily headed.

In the meantime if you have any query or special application for HI-SHEAR our Technical Department will be pleased to give you every assistance.

Technical Data Publication on the HI-SHEAR Riveting System is available on request.

BRITISH PATENT
Nos.
567446 & 601693

HUCK FASTENING SYSTEM

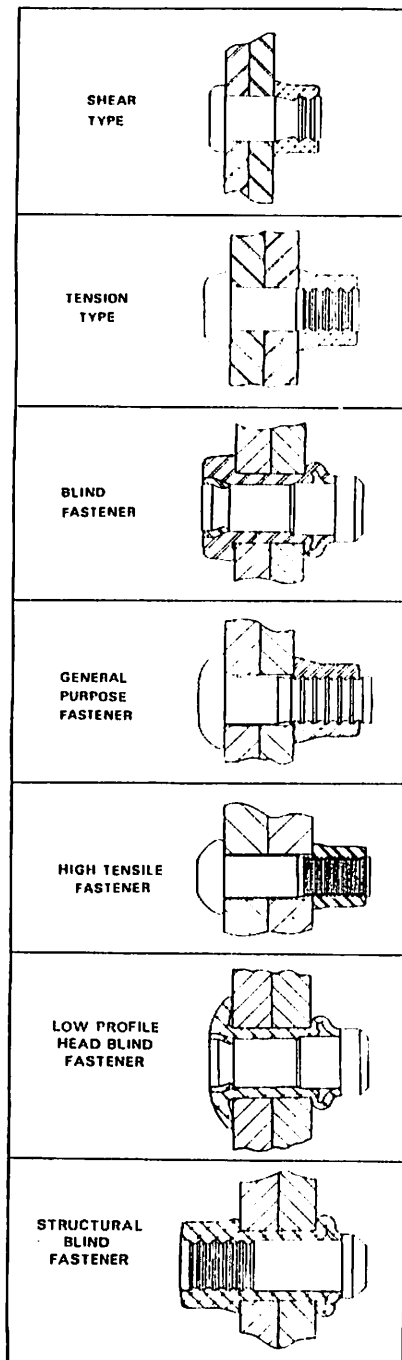

The Huck Fastening System offers users in all types of industry the widest possible choice of fasteners and tooling for severe service applications.

Designers, buyers and production engineers can save money, trouble and time by consulting us first.

Huck fastener materials range from inexpensive mild steel to sophisticated alloys and titanium: the fasteners themselves have the inherent characteristics of high strength-to-weight ratio, low installation cost, wide variety of head styles and finishes, and diameters from $\frac{1}{8}$ " to 1".

Huck tooling is simple and straightforward, as is work preparation. Tools range from lightweight hand tools, manually operated, to rugged high pressure hydraulic tools that take all the hard work out of installing the larger diameter high tensile fasteners.

Already well established in the Aircraft Industry throughout the world, the Huck Fastening System is becoming increasingly accepted for new industries such as containers, and traditional industries such as shipbuilding and heavy engineering.

Write or telephone for Huck Fastening System information to meet your particular requirements or help solve your problem.

