

**Ministry of Defence  
Defence Procurement Agency, ADRP2  
Abbey Wood  
Bristol  
BS34 8JH**

## **OBSOLESCENCE NOTICE**

All DTD specifications were declared obsolescent from 1<sup>st</sup> April 1999. All DTD 900 series approvals also lapsed at that time. The standards will no longer be updated but will be retained as obsolescent documents to provide for the servicing of existing equipment.

### **Further Guidance**

The aim in declaring the specifications obsolescent is to recognise that the documents are not being updated and thus should be used with care by both purchaser and supplier. For example, a specification could contain valid technical information but may also contain type approval clauses that contradict procurement policy and/or use materials that do not comply with environmental legislation. The obsolescent specification can still be used as a basis for a purchase provided that the supplier and purchaser agree suitable changes to the specification within the purchase order/contract.

For the DTD 9000 system, each specification has provided an MoD approved material and process. For these items, the declaration of obsolescence will constitute the termination of both the extant MoD approval and the continuing MoD assessment that had underpinned those approvals. Again, the technical content of the document remains valid and can be used by both purchaser and supplier as a basis for a contract but an acceptable (to the parties) approval/assessment procedure would be required.

**Aerospace Material Specification**  
**VULCANIZED BUTADIENE-ACRYLONITRILE RUBBERS**  
**(FUEL AND SYNTHETIC OIL RESISTANT)**

---

*NOTE 1. This specification is one of a series issued by the Procurement Executive, Ministry of Defence, either to meet a limited requirement not covered by an existing British Standard for aerospace material, or to serve as a basis for inspection of material, the properties and uses of which are not sufficiently developed to warrant submission to the British Standards Institution for standardization.*

*NOTE 2. It is one of a series of rubber specifications in which the material is classified by the base polymer employed.*

*NOTE 3. The tests employed in this specification are chosen for their reproducibility and ability to control the properties of the material. They are not intended to be simulated service tests, which, because of variability of test conditions, may be unsatisfactory for control purposes.*

*NOTE 4. The intended applications and the limitations of materials to this specification are given in Section 1 of the specification and are for guidance only. In case of doubt users are advised to confirm the suitability of the material for any given application.*

*NOTE 5. Further guidance on the choice of rubber for any particular purpose may be obtained from Appendix 1 of DR Mat Tech. Memo. No 7 "Rubber in Engineering Design" and SBAC TS No 97 "Recommended Design Guide on Rubber Materials for Aerospace Applications".*

*NOTE 6. Except where otherwise stated, the methods of test shall be as described in British Standard 903 - "Methods of Testing Vulcanized Rubber", the edition current at the date of tender or contract being intended.*

---

**SECTION 1**

**Scope**

**1.1 Scope**

The materials covered by this specification are intended for the production of items such as sheets, mouldings and certain extrusions, mainly for sealing applications in contact with petroleum-based fuels and diester based lubricants. They are generally suitable for use within the range - 40°C to 120°C for continuous operation and for certain selected applications may be considered for use up to 150°C for short intermittent periods. They are unsuitable for use in contact with phosphate ester hydraulic fluids and have poor ozone resistance.

*NOTE. At ordinary temperatures and in the absence of hostile environments, eg when properly stored, these rubbers deteriorate only very slowly. However, the rate of deterioration increases markedly with increased temperature and the service life of a rubber therefore depends upon the operational temperature. Conversely, the maximum temperature at which a rubber may be used depends upon the useful life required.*

**1.2 Classification**

Five different hardness values are covered (Grades 50, 60, 70, 80 and 90; Grade 50 being the softest) and the grade required must therefore be stated on all drawings and contracts. Where a nominal hardness other than those quoted is necessary, this can be specified and the basic requirements other than hardness shall be those specified for the grade embracing the proposed nominal hardness. If a tolerance is required which is tighter than those quoted (+5, -4 or +3, -4 in the case of Grade 90) this should be specified but should not be less than  $\pm 3$ .

**SECTION 2**

**Related documents**

**1. Reference is made in this document to the following:**

- B.S. 903 - Methods of testing vulcanized rubber.
- B.S. 1449: Part 1 - Carbon steel plate, sheet and strip.
- B.S. 1470 - Wrought aluminium and aluminium alloys for general engineering purposes - plate, sheet and strip.
- B.S. 3734 - Schedule of tolerances for rubber products in solid rubber and ebonite.

- B.S. F69 - Packaging and identification of vulcanized rubber items.
- B.S. L70 - Sheet and strip of aluminium - copper - magnesium - silicon - manganese alloy (solution treated at room temperature).
- B.S. S511 - Deep drawing carbon steel sheet and strip.

Except where otherwise stated, the edition current at the date of tender, contract or order is intended.

## SECTION 3

### General Requirements

#### 3.1 Composition

The materials covered by this specification shall consist of a butadiene-acrylonitrile copolymer suitably compounded and cured to meet the requirements of Sections 4 and 5 of this specification. No factice, reclaim or ground vulcanized waste shall be used. All ingredients of the mix shall be of recognised rubber quality and shall be free from foreign matter.

#### 3.2 Freedom from Defects

The selection and processing of the ingredients shall be such that the mix is homogeneous and that the parts made from it shall be free from surface imperfections, blisters, porosity, inclusions and undispersed ingredients, and other defects which would impair satisfactory performance. It shall not show excessive bloom.

## SECTION 4

### Type approval of Rubber Compounds

#### 4. Type Approval

4.1 Before any particular rubber compound can be accepted as complying with the requirements of this specification, it shall have received type approval. To obtain such approval, the manufacturer (of the fully compounded stock) shall satisfy the Quality Assurance Authority that the compound will meet all the requirements of this specification.

4.2 The Quality Assurance Authority for material to this specification is:

Director, Materials Quality Assurance (DMQA),  
Headquarters Building,  
Royal Arsenal East,  
Woolwich,  
London SE18 6TD.

4.3 When applying for type approval the manufacturer shall submit the following:

4.3.1 Full details of the composition together with details of the standard vulcanizing conditions. This information will be treated as confidential.

4.3.2 A sample of the vulcanized material consisting of two sheets each in the form of a two-thickness test sheet, vulcanized at a temperature appropriate to the mix for a time appropriate to the thickness of the test sheet. No additional vulcanizing shall be given to the thicker portion of the test sheet. Each sheet shall be approximately 250mm square,  $2.00 \pm 0.15$ mm thick, with a section along one side 35-50mm wide and  $6.30 \pm 0.15$ mm thick.

If desired for the purpose of compression set tests, part of the 6.30mm thick section may be moulded in the form of cylindrical buttons conforming to the requirements of a Type 1 test piece as defined in B.S. 903: Part A6.

When such buttons are moulded, the cavities shall be individually charged with pellets and not by the flow of excess mix from the remainder of the mould. No additional vulcanizing shall be given to the buttons.

The minimum number of buttons moulded shall be nine and they shall be in a group at one end of the thick section.

4.3.3 Test results on a sample identical to the one submitted and prepared from the same batch of material.

4.3.4 The proposed value for nominal density and, if required, nominal hardness (see Clause 1.2).

#### 4.4 Tests

The tests listed in Table 1 shall be carried out on test pieces cut from the sample sheet specified in Clause 4.3.2. Each property of the material, when determined by the method given in Table 1, shall comply with the requirement also listed in Table 1.

No absolute limits are set for density but this shall be determined and a nominal value agreed between the manufacturer and the Quality Assurance Authority.

- 4.5 After formal type approval has been given, no change in composition or vulcanizing conditions shall be made without the consent of the Quality Assurance Authority.

### SECTION 5

#### Routine Quality Control

##### 5. Frequency of Testing

- 5.1 The first production batch and subsequently at least every tenth batch of mix shall be tested for compliance with the requirements of tests (a) to (h) inclusive of Table 1 on a sample sheet as described in 4.3.2.
- 5.2 All other batches shall be similarly tested for compliance with the requirements of tests (a), (b), (e), (f)(i)(a) and (f)(ii) of Table 1.
- 5.3 The Quality Assurance Authority may, at any time, require any batch to be checked for compliance with any requirement in Table 1.

### SECTION 6

#### Rubber Items (Parts or Components)

##### 6. Manufacture and Inspection

###### 6.1 Manufacture

Rubber items shall be manufactured from material which complies with all the requirements of Section 3, 4 and 5 of this specification.

###### 6.2 Inspection

If the finished items are required to comply with a specification relevant to that item, they shall be inspected and tested for compliance with the requirements of that specification.

In the absence of such a specification, the following shall apply:

###### 6.2.1 Sampling

Unless otherwise agreed with the customer or Quality Assurance Authority concerned, sample items shall be taken from each lot produced from each batch of mix.

###### 6.2.2 Freedom from defects

Finished rubber items shall be free from surface imperfections, porosity, voids, inclusions, flow marks, inadequate joint of moulding blank, and other defects which would impair satisfactory performance, eg excessive grain in calendered sheet or extrusions.

Surface finish shall be smooth, unless otherwise stated in the relevant drawing, contract or order, eg items may be specified with shallow cloth marking on one or more surfaces.

###### 6.2.3 Dimensions

The dimensions and tolerances of finished rubber items shall be as stated on the relevant drawing, contract or order. Methods of measurement of dimensions shall be in accordance with B.S. 3734 unless otherwise stated.

###### 6.2.4 Physical tests

Sample items shall be tested as agreed with the customer or Quality Assurance Authority concerned, due regard being paid to whether standard test pieces can be obtained from them. The requirements for the results of such tests, if not complying with the requirements of Table 1 (eg where results are reported as apparent hardness or are obtained on test pieces which have been buffed during preparation), shall be agreed with the customer or Quality Assurance Authority concerned.

6.2.5 *Chemical tests*

Chemical analysis may be carried out on sample items, as practicable, to verify that the composition is essentially in accordance with Section 3.

6.3 **Quality assurance documents**

The manufacturer shall state on each quality assurance document (eg release note) the part number, the specification number and grade, date of vulcanization (quarter and year), the item lot number, and composition reference (manufacturer's designation) of the rubber material used.

6.4 **Packaging and identification**

Unless otherwise stated on the drawing or in the contract or order, components shall be packaged and the package identified in accordance with the requirements of B.S. F69.

TABLE 1

Test	Test requirement					Test method
	Grade 50	Grade 60	Grade 70	Grade 80	Grade 90	
(a) Hardness, IHRD	50+5 -4	60+5 -4	70+5 -4	80+5 -4	90+3 -4	Appendix I
(b) Density, Mg/m <sup>3</sup>	Within $\pm 0.02$ of the agreed value					B.S. 903: Part A1 Method A
(c) Tensile strength, MPa min	8.0	9.0	10.5	11.0	12.5	B.S. 903: Part A2 Dumb-bell test pieces
(d) Elongation at break, % min	300	300	230	150	100	
(e) Compression set, % max	30	25	20	20	20	Appendix II
(f) Resistance to fluids						Appendix III
(i) Volume change, % max, after immersion in:						
(a) Liquid B	+30	+30	+30	+25	+20	
(b) Liquid 101	+10	+8	+8	+8	+8	
(ii) Volume change, % max, after immersion in Liquid B followed by drying	-12	-10	-8	-8	-5	
(iii) Change in Hardness, IRHD max, after immersion in Liquid 101	-10	-8	-8	-8	-8	
(g) Resistance to heat ageing						B.S. 903: Part A19 Method A or B 168 hours at $100 \pm 1^\circ\text{C}$
(i) Change in hardness, IRHD max	-0 +10	-0 +10	-0 +8	-0 +8	-0 +8	
(ii) Change in tensile strength, % of original value, max	-10	-10	-10	-10	-10	
(iii) Change in elongation at break, % of original value, max	-35	-35	-30	-30	-30	
(h) Resistance to low temperature. Temperature $^\circ\text{C}$ at which rigidity modulus shall not exceed 70 MPa	-30	-30	-25	-15	-5	B.S. 903: Part A13
(i) Freedom from adhesion to and corrosion of metals	No adhesion to the metal surfaces, nor corrosion or pitting of the metal. Discoloration will not be considered objectionable.					Appendix IV

## APPENDIX I

### Method for the determination of hardness

- (i) Hardness measurements required for test (a) of Table 1 shall be made by Method N described in B.S. 903: Part A26 using one specimen of the thicker part of the test sheet specified in Clause 4.3.2 superimposed upon the thinner part of the same test sheet.
- (ii) For the determination of the change in hardness required for tests (f)(iii) and (g)(i) in Table 1, the measurements shall be carried out, before and after ageing, by Method N of B.S. 903: Part A26 using two specimens plied together, of the thinner part of the test sheet specified in Clause 4.3.2.

## APPENDIX II

### Method for the determination of compression set

Compression set measurements shall be made by Method A of B.S. 903: Part A6, using Type 1 test pieces from the thicker section of the test sheet specified in Clause 4.3.2. The test pieces shall be lubricated.

The time of test shall be 24 hours and the temperature during the compression period shall be  $100 \pm 1^\circ\text{C}$ .

## APPENDIX III

### Method for the determination of resistance to fluids

Measurements shall be made after immersion in:

- (a) Liquid B of B.S. 903: Part A16. The temperature of test shall be  $40 \pm 1^\circ\text{C}$  and the period of immersion 48 hours.
- (b) Liquid 101 of B.S. 903: Part A16. The temperature of test shall be  $100 \pm 1^\circ\text{C}$  and the period of immersion 168 hours.
  - (i) Volume change measurements shall be made by the volumetric method of B.S. 903: Part A16, para 7.3. Drying in test (f)(ii) shall be for a period of 18 hours at  $100 \pm 1^\circ\text{C}$ .
  - (ii) Hardness change measurements shall be made as described in Appendix I.
  - (iii) Change in tensile strength and elongation at break shall be determined using the method described in B.S. 903: Part A16, para 10.1 using Type 2 dumb-bell test pieces.

## APPENDIX IV

### Method of test for freedom from adhesion to and corrosion of metals

During the preparation of the test pieces and metals and throughout the procedure all test pieces and prepared metals shall be handled with medical fingercots and polypropylene forceps to avoid surface contamination.

Two test pieces approximately 20mm square cut from the thinner part of the test sheet specified in Clause 4.3.2 shall be cleaned with cotton wool pads moistened with acetone. The test pieces shall be allowed to dry and then stored in a desiccator for a minimum period of 24 hours at  $23 \pm 2^\circ\text{C}$  prior to testing.

Two metal strips, one of aluminium alloy to B.S. L70 or B.S. 1470 HS15 and the other of mild steel to B.S. S511 or B.S. 1449: Part 1B Type CR3/FF, each approx 100mm long by 25mm wide and having a minimum thickness of 8mm in order to withstand the clamping force without deflection, shall be prepared immediately prior to the test as follows:

- (i) Thoroughly scour with  $53\mu\text{m}$  (300 mesh) pumice powder on a cotton wool pad wetted with distilled water until a matt surface is obtained.
- (ii) Wash away the powder with distilled water.
- (iii) Rinse the metal strips with acetone and allow to dry.

The two rubber test pieces shall be taken from the desiccator and placed between the prepared surfaces of the two metal strips. The metal/rubber/metal sandwich shall be placed in the assembly jig (Fig 1) and a mass of 10 kg applied (Figs 2a and 2b).

The Hoffmann screw clamps, one at each end of the sandwich, shall be tightened with just sufficient force to maintain the clamping force when the 10 kg mass is removed.

The assembled sandwich shall be placed in an air oven at  $100 \pm 1^\circ\text{C}$  for 168 hours. The assembly shall then be removed from the oven, allowed to cool to room temperature ( $23 \pm 2^\circ\text{C}$ ) and the clamps removed.

The assembly shall be carefully parted and the test pieces removed from the metal surfaces. The parted assembly shall be left on a wooden bench for 24 hours at room temperature ( $23 \pm 2^{\circ}\text{C}$ ) in an atmosphere free from corrosive fumes, eg in a balance room. At the end of this period the metal surfaces shall be examined for corrosion and pitting, and adhesion of the test pieces to the metals. Adhesion shall be considered to have occurred if particles of the test pieces remain adhered to the metal surfaces.

---

Approved for issue,

N. L. PARR,

Director of Research, - Materials.

---

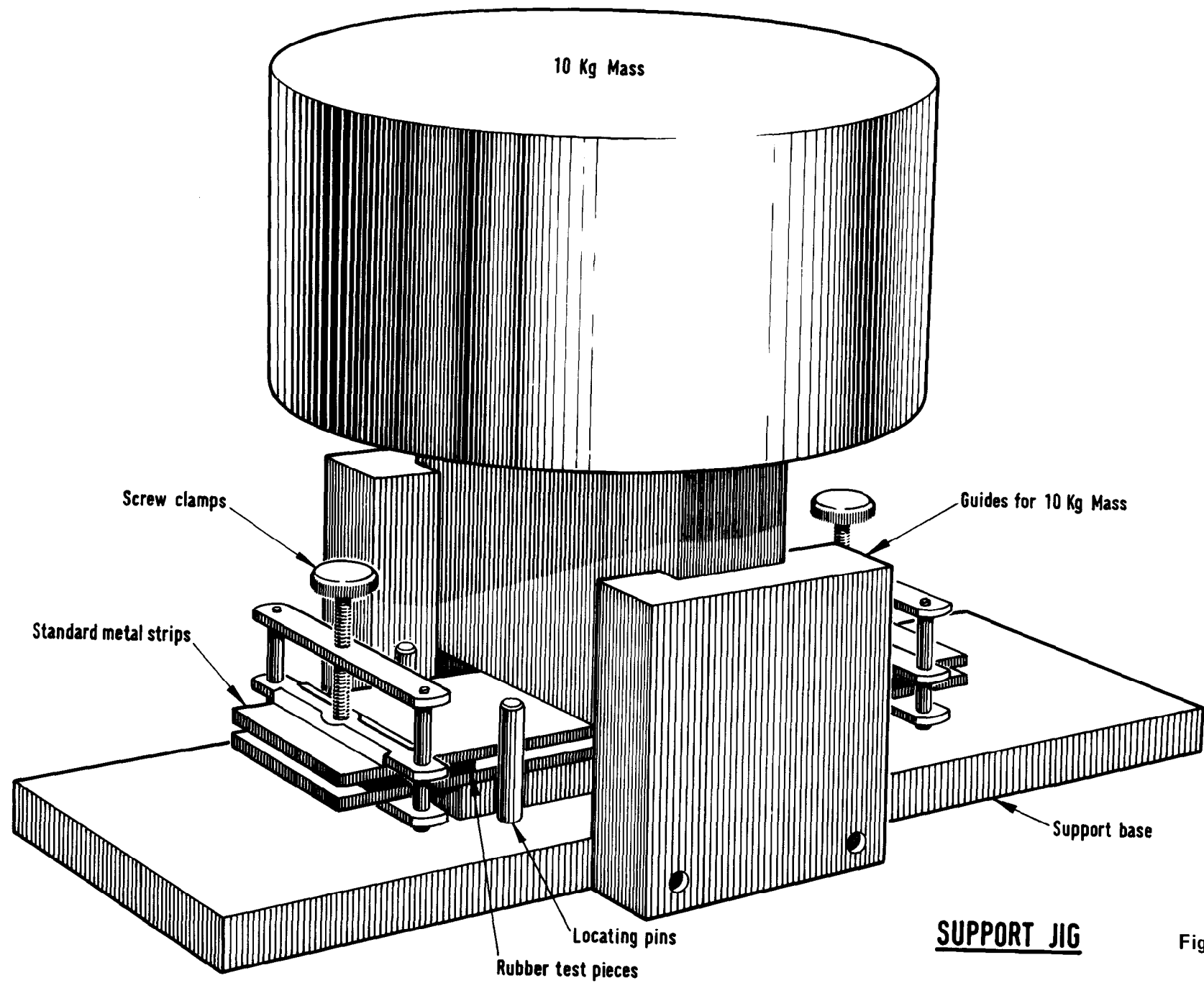

**SUPPORT JIG**

Fig. 1



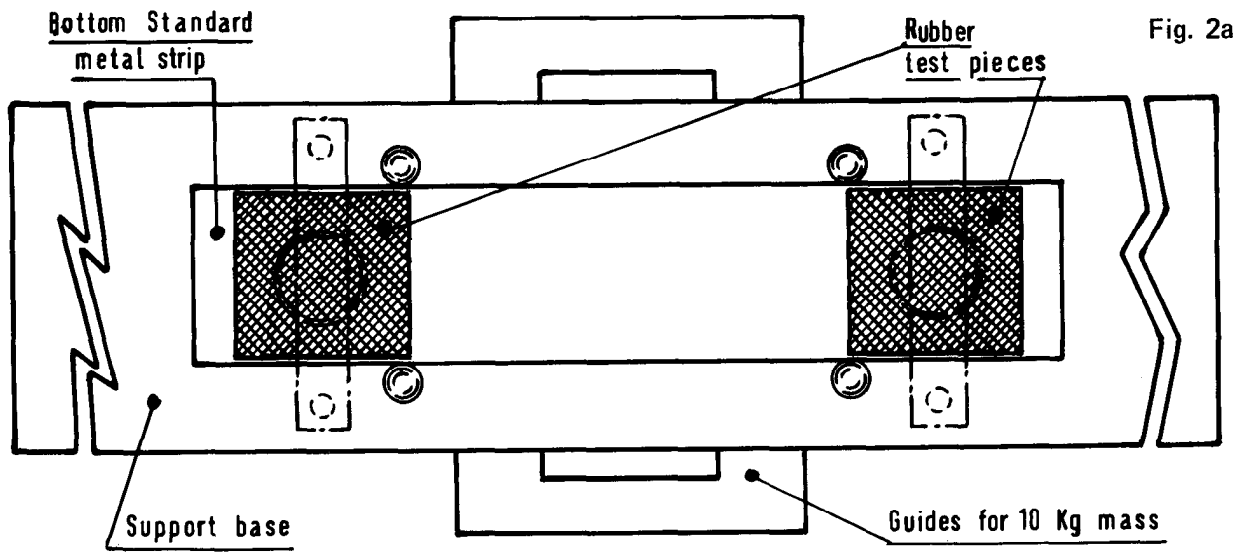

Fig. 2a

PLAN VIEW WITH CLAMPS, TOP STD. METAL STRIP & 10 Kg MASS REMOVED

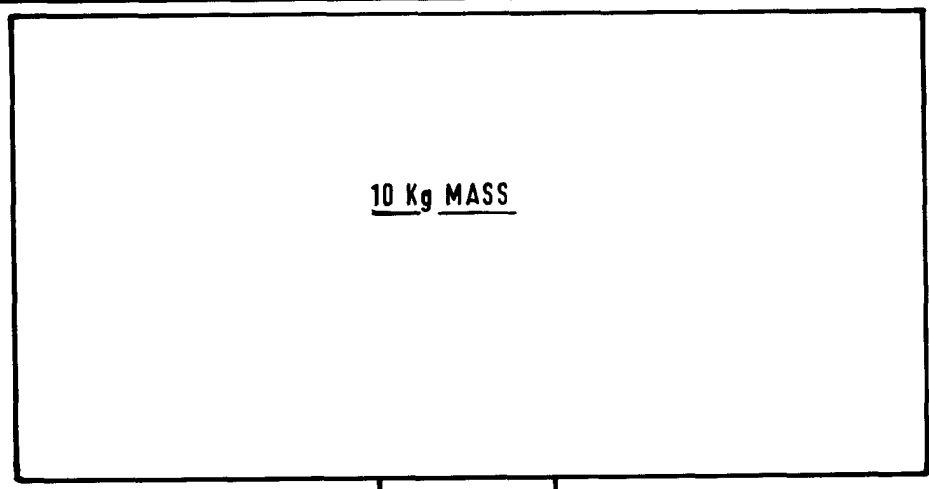
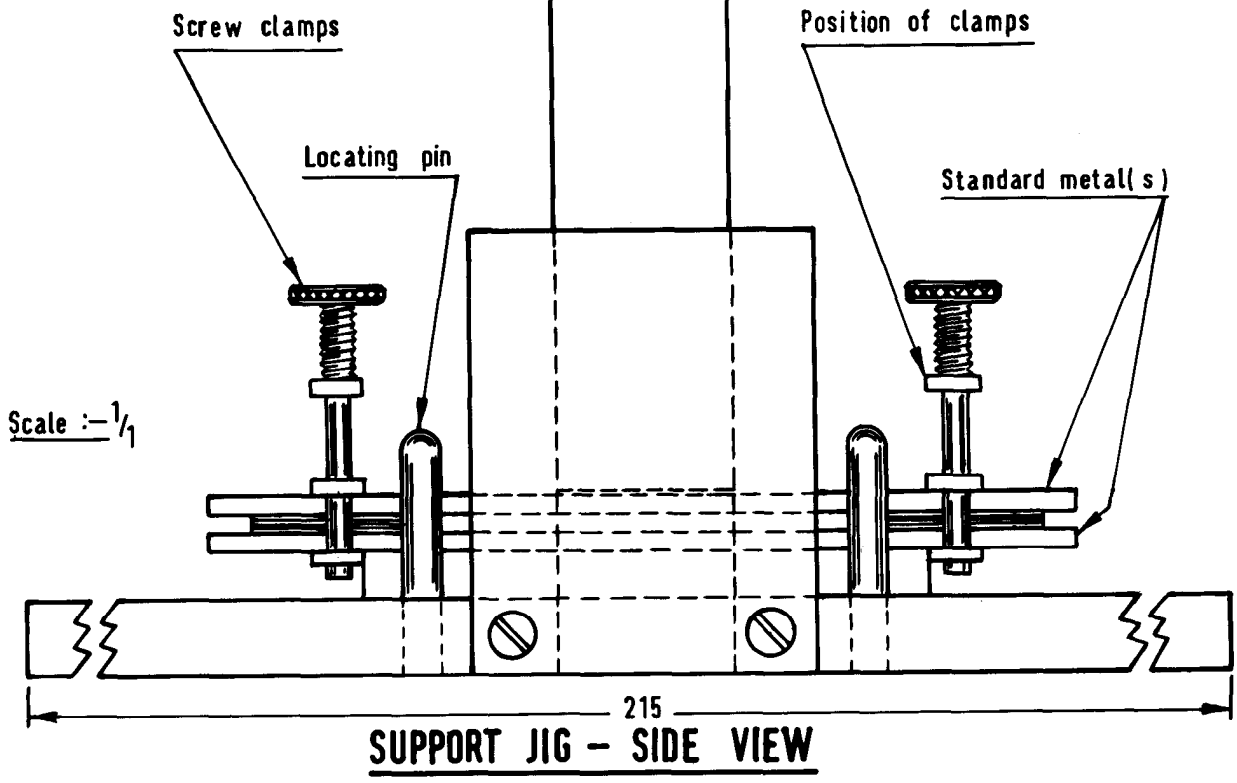

Fig. 2b



© Crown Copyright 1978  
First Published 1978

HER MAJESTY'S STATIONERY OFFICE

*Government Bookshops*

49 High Holborn, London WC1V 6HB  
13a Castle Street, Edinburgh EH2 3AR  
41 The Hayes, Cardiff CF1 1JW  
Brazenose Street, Manchester M60 8AS  
Southey House, Wine Street, Bristol BS1 2BQ  
258 Broad Street, Birmingham B1 2HE  
80 Chichester Street, Belfast BT1 4JY

*Government Publications are also available  
through booksellers*

40p

ISBN 011 771636 7