

FIG. 12
 FUSELAGE CONSTRUCTION
 DIAGRAM

SCALE: 1/20

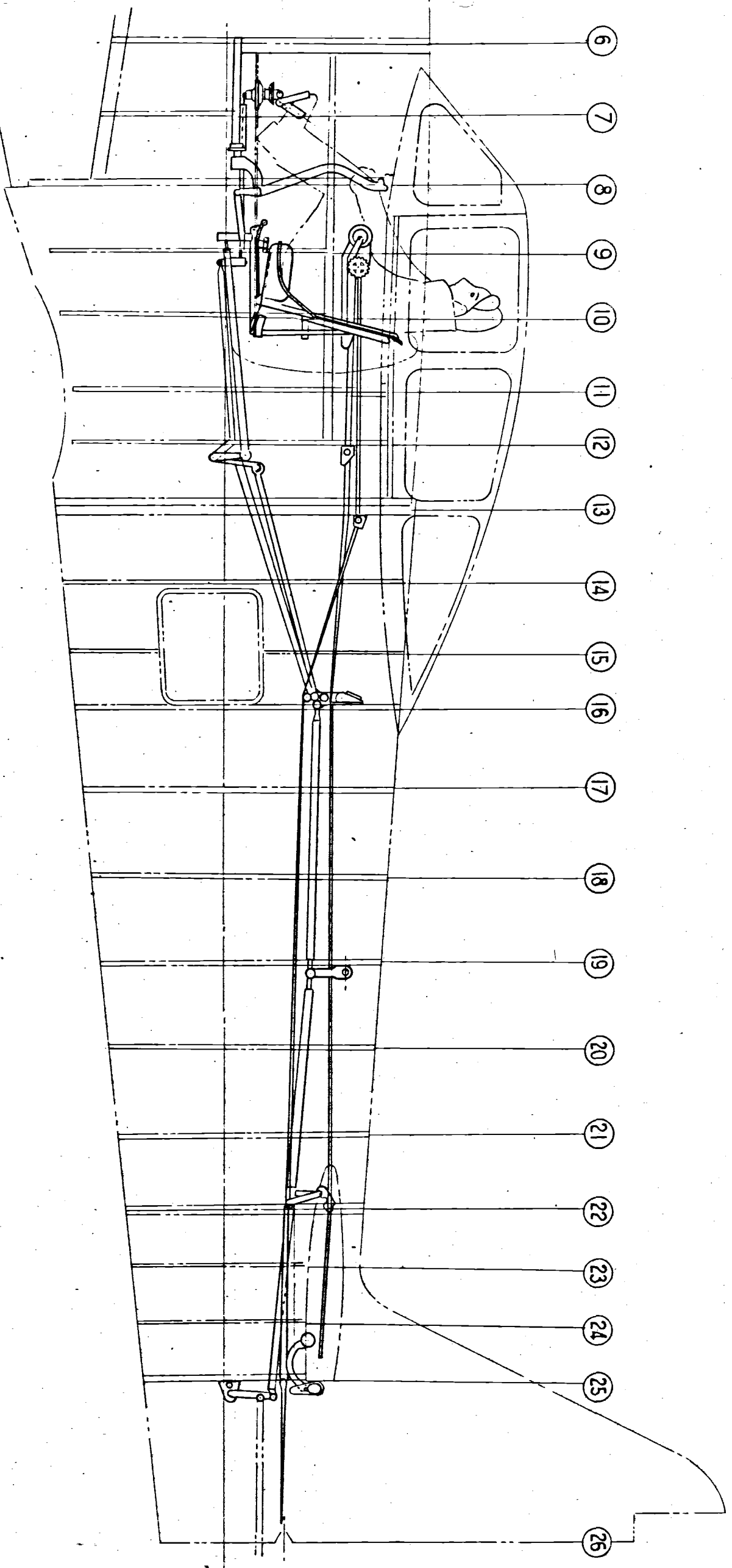

FIG. 17.
CONTROL SYSTEM DIAGRAM.
SCALE 1/20.

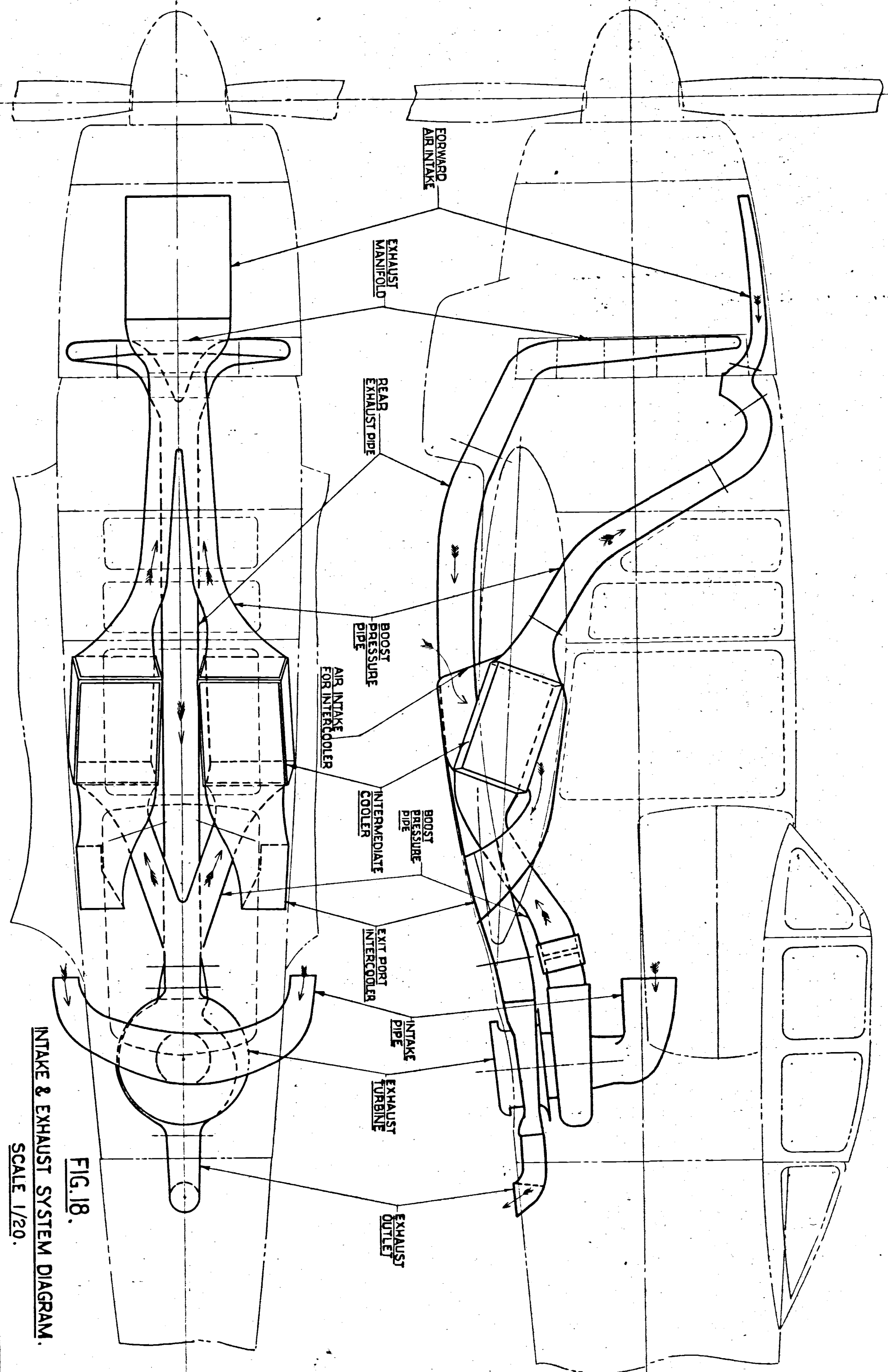

FIG. 18.

INTAKE & EXHAUST SYSTEM DIAGRAM.

SCALE 1/20.

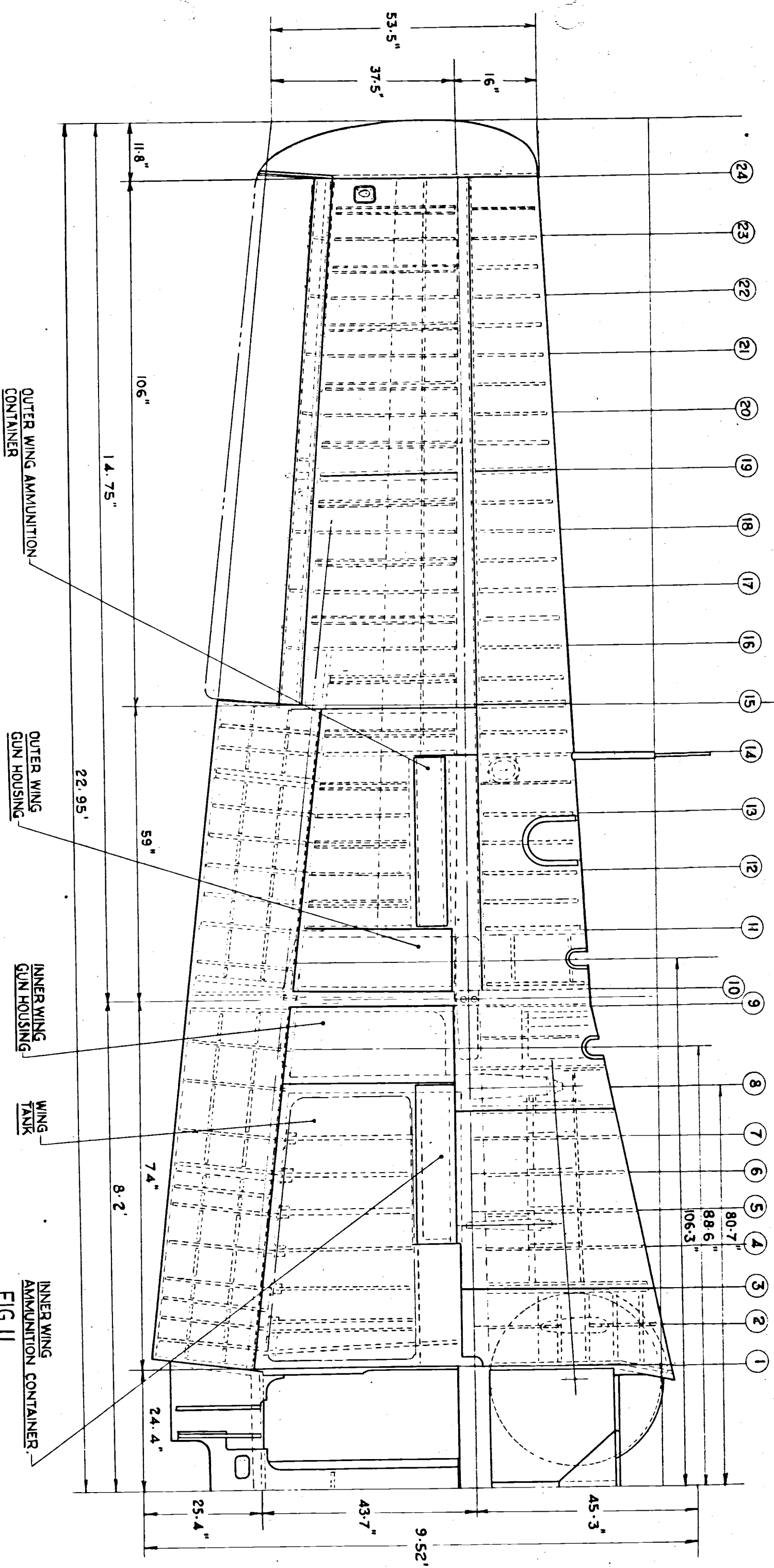

FIG. 11

MAIN WING CONSTRUCTION DIAGRAM.

SCALE 1/20.

FIG. 3.

CENTRE SECTION. CROSS SECTION TH 346-8454
MAX. WING THICKNESS 17%. MAX. CAMBER 2.8%.

SECTION AT INNER TO OUTER WING JOINT TH 346-75045
MAX. WING THICKNESS 14%. MAX. CAMBER 2.8%.

SECTION AT HYPOTHETICAL WING TIP TH 346-75505
MAX. WING THICKNESS 10.0%. MAX. CAMBER 2.0%.

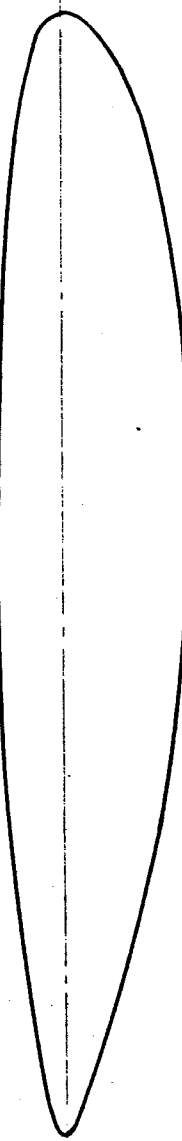
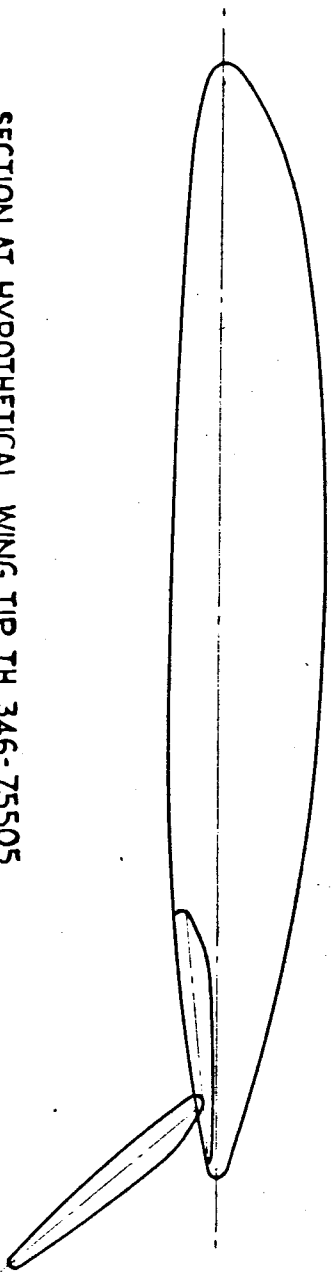
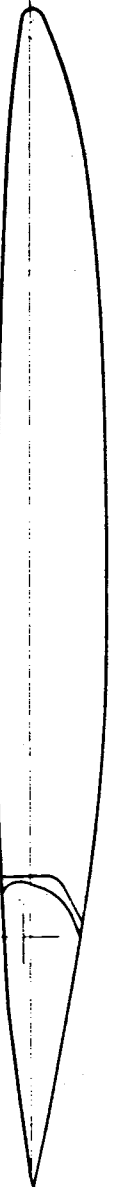
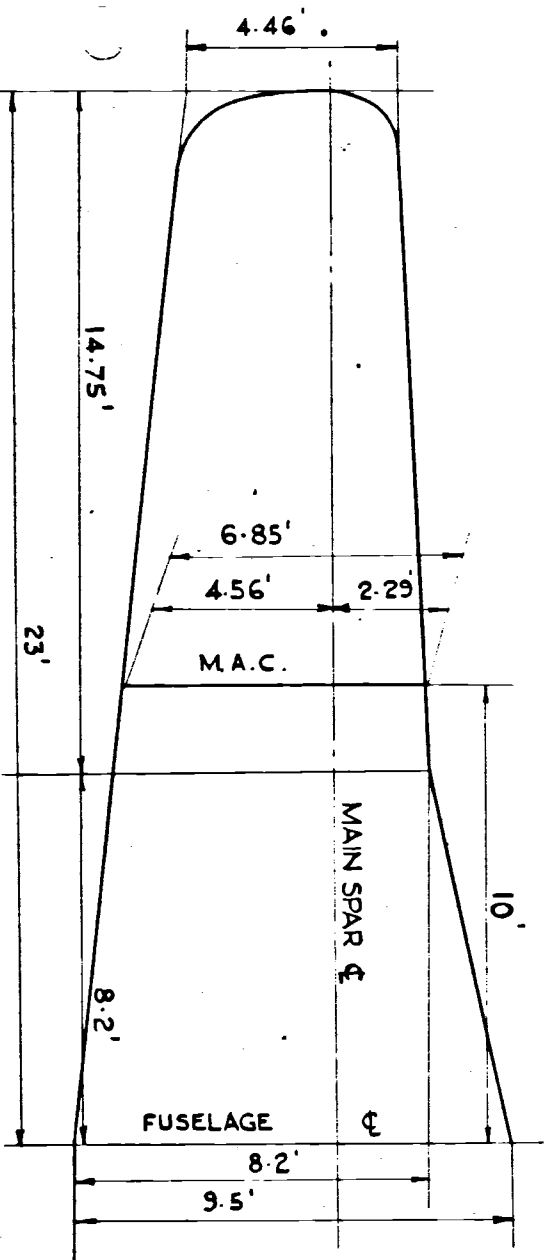

FIG. 4.

LOCATION OF MEAN AERODYNAMIC CHORD.



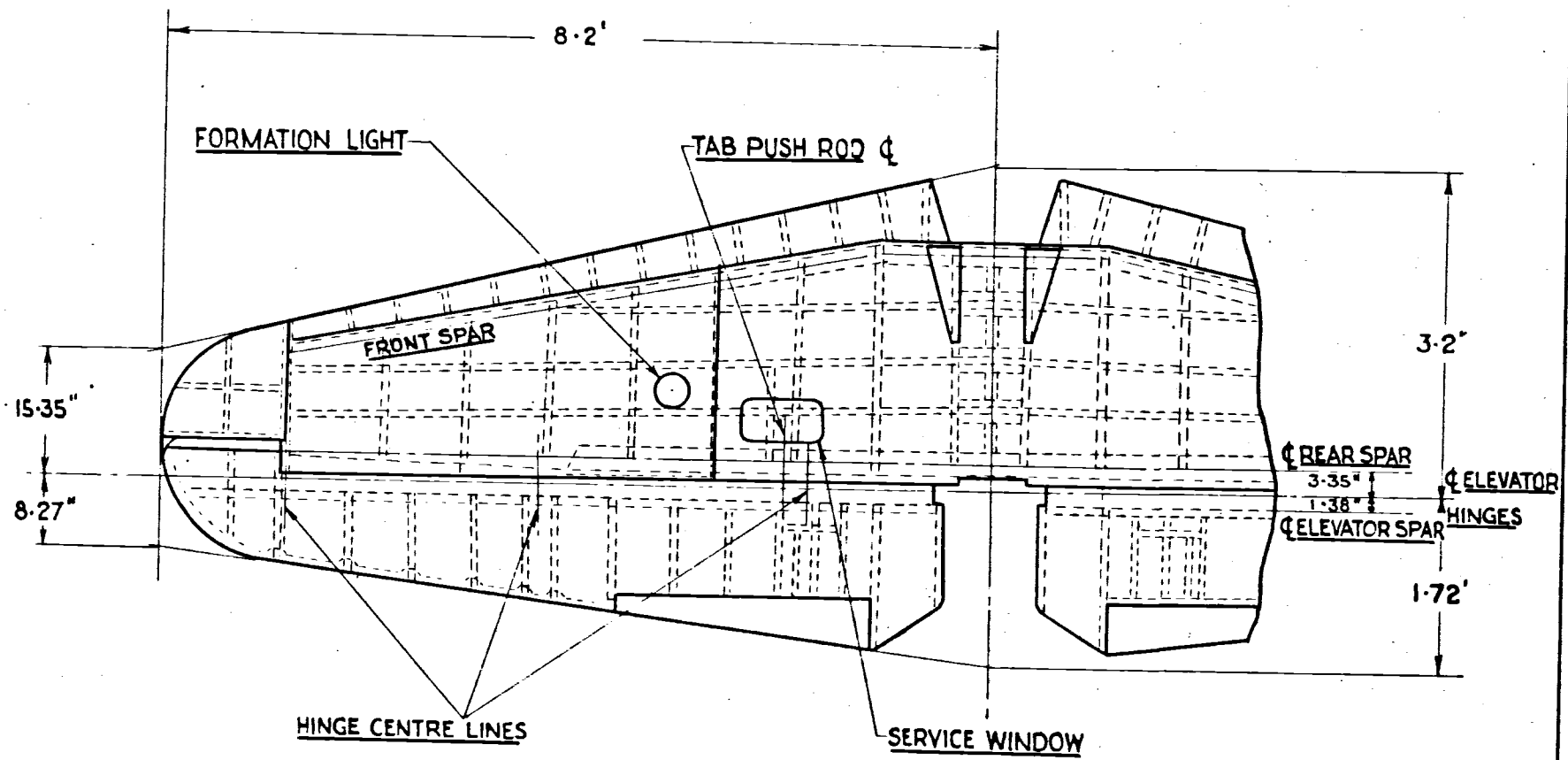

FIG.14
HORIZONTAL TAIL PLANE CONSTRUCTION
DIAGRAM.
SCALE 1/20.

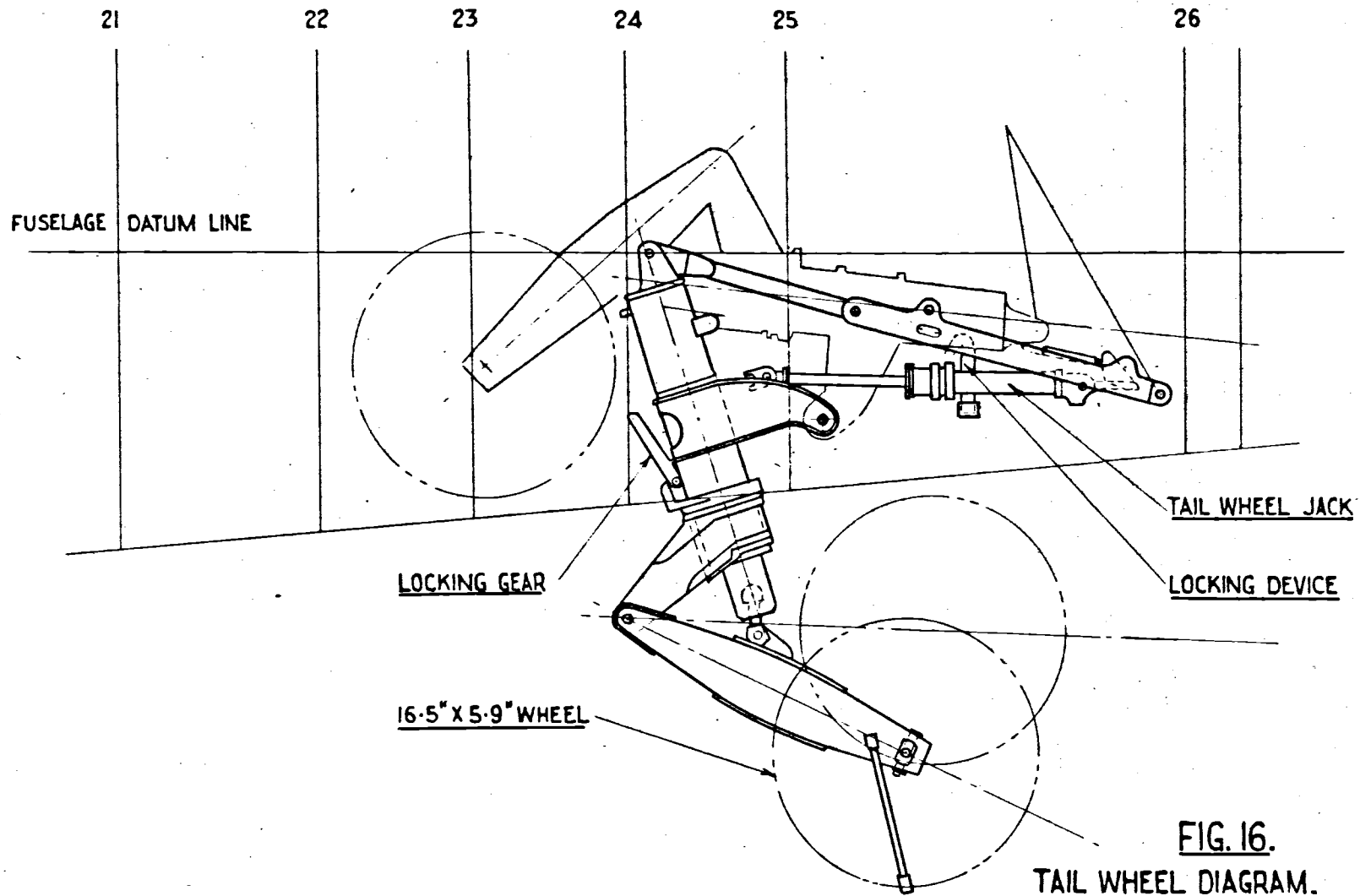

FIG. 16.
TAIL WHEEL DIAGRAM.
SCALE 1/10.

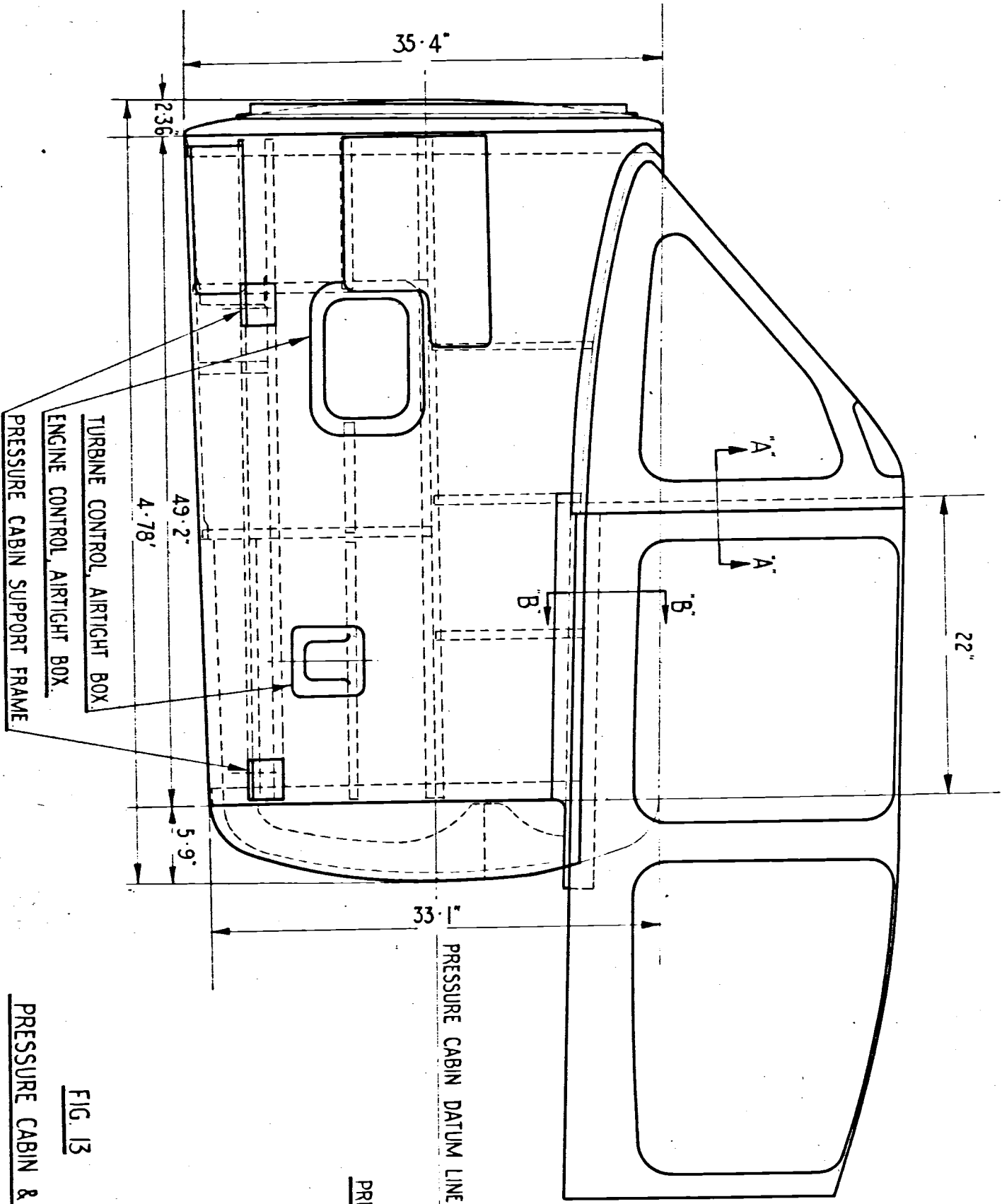
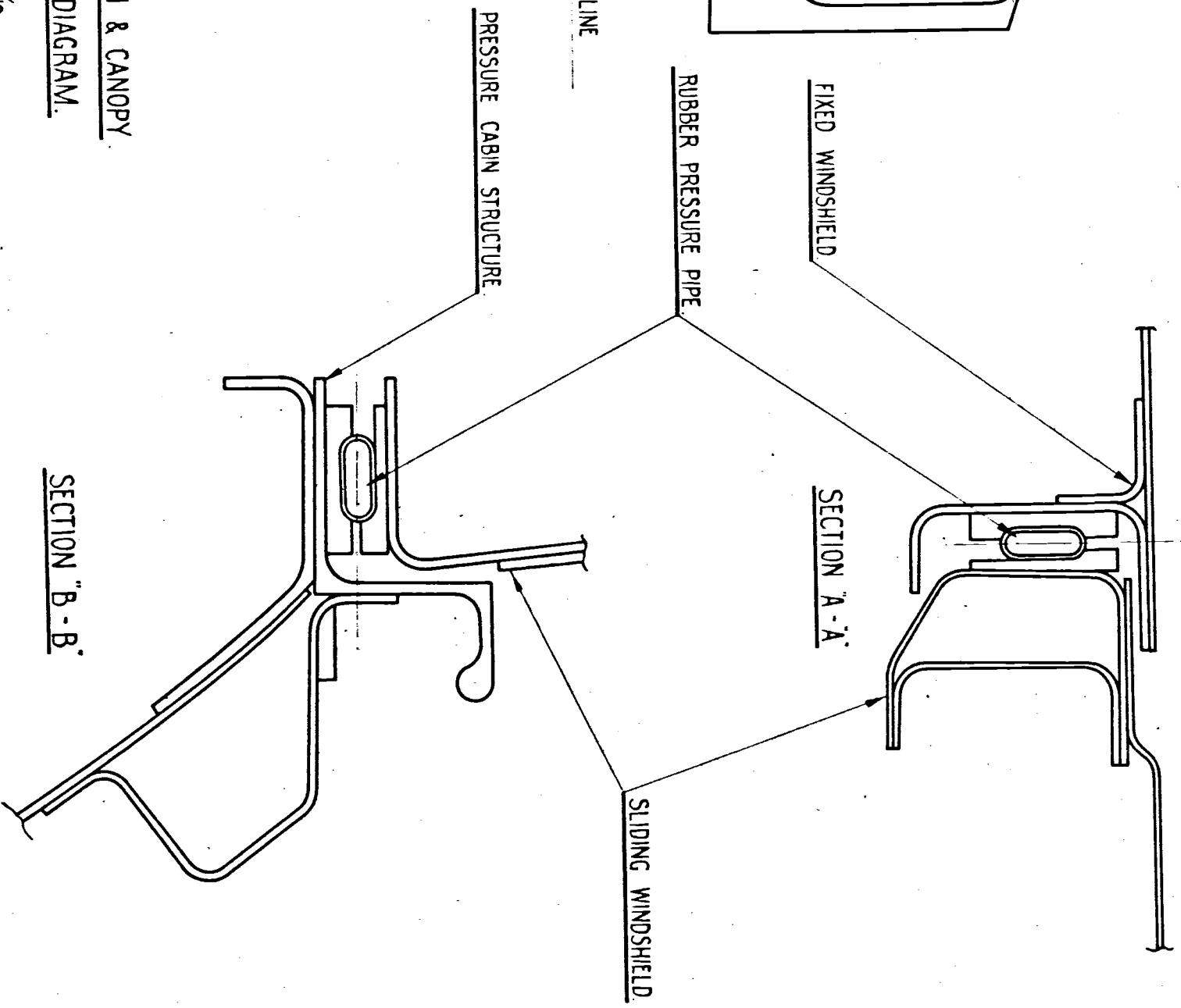

FIG. 13

PRESSURE CABIN & CANOPY
CONSTRUCTION DIAGRAM.

SCALE - 1/16



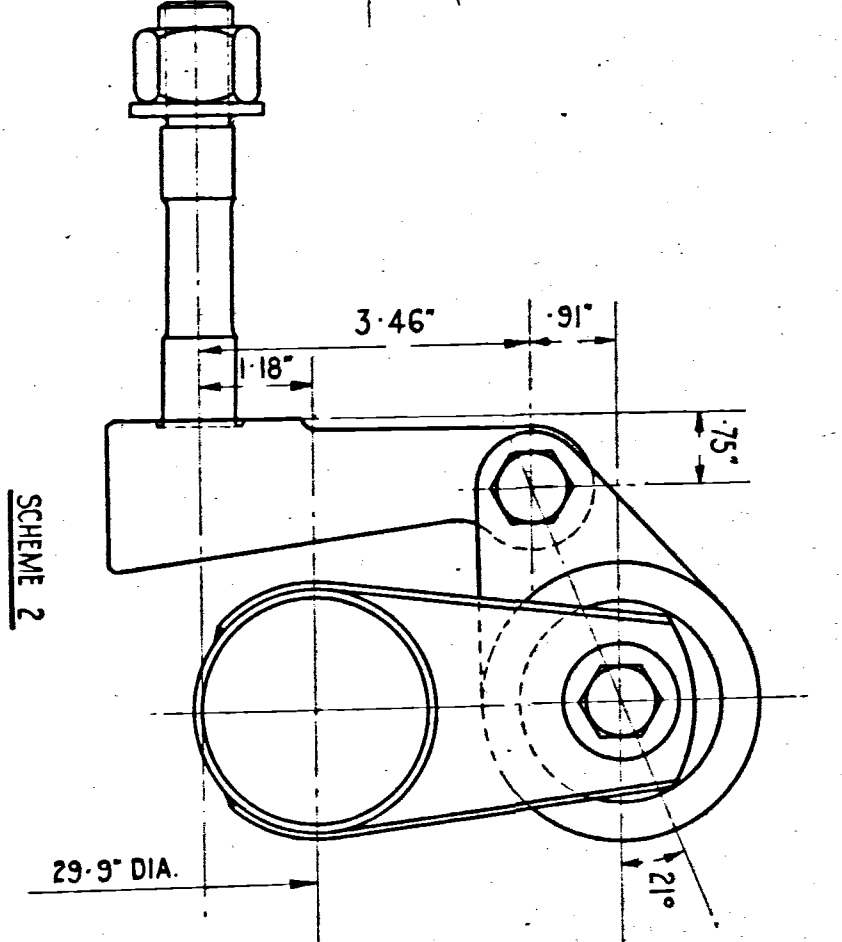
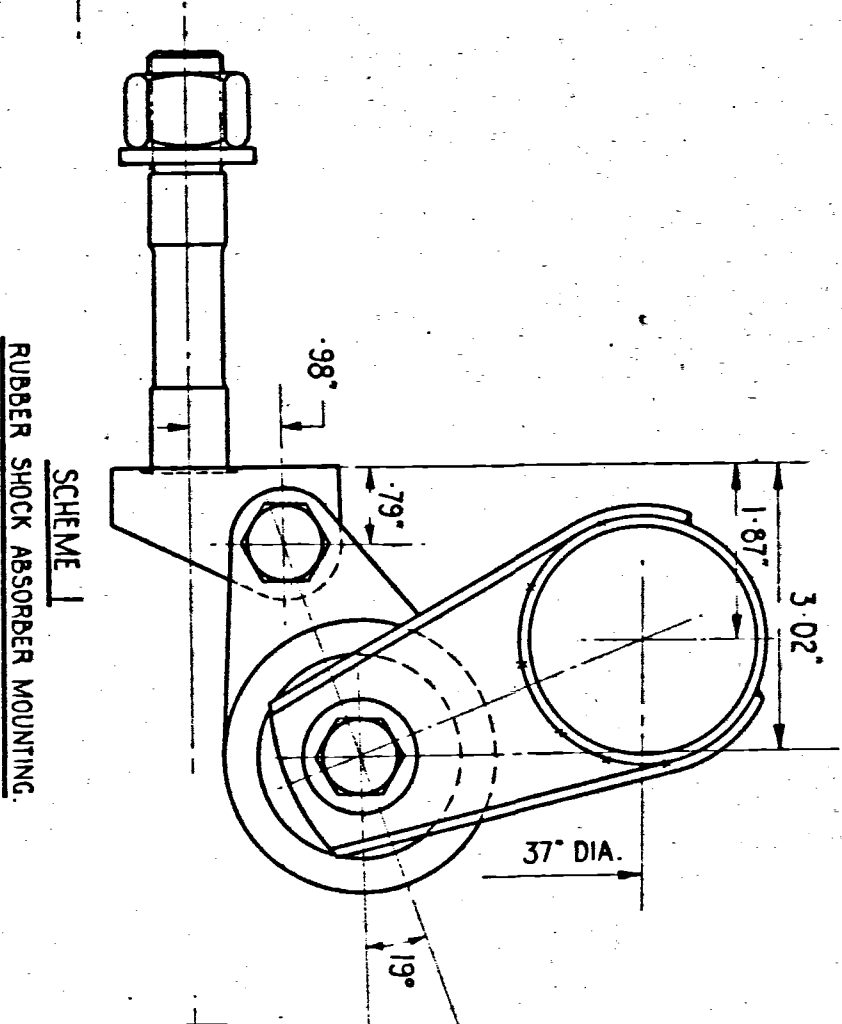
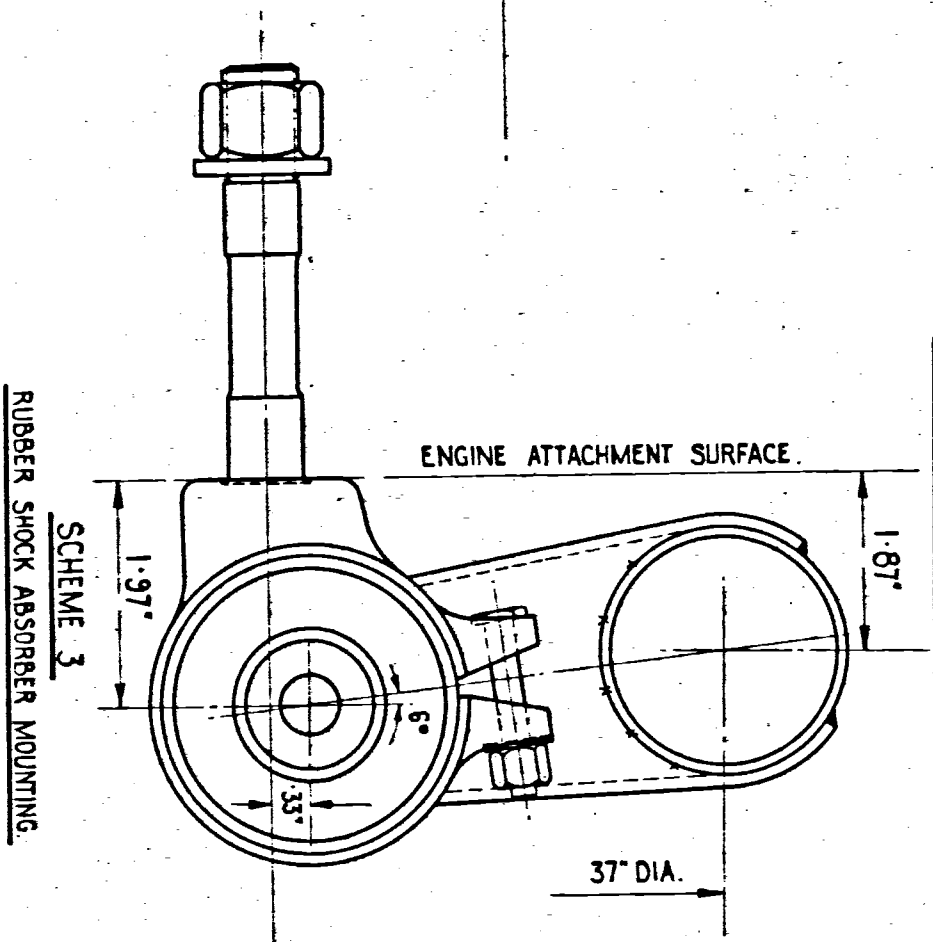
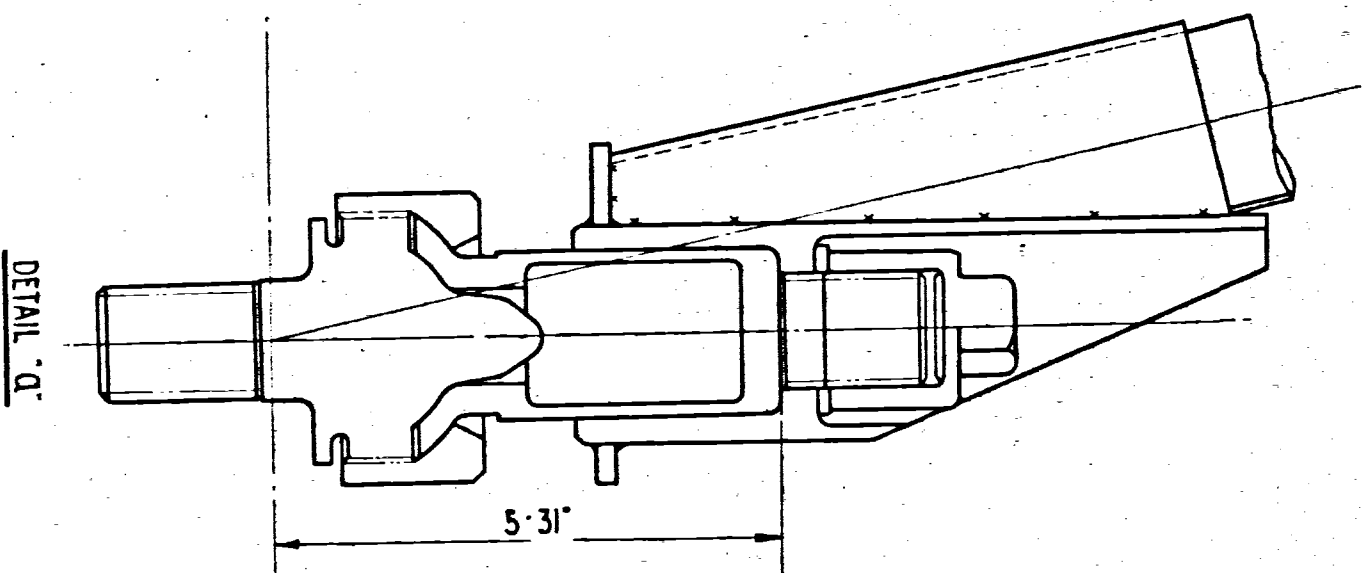
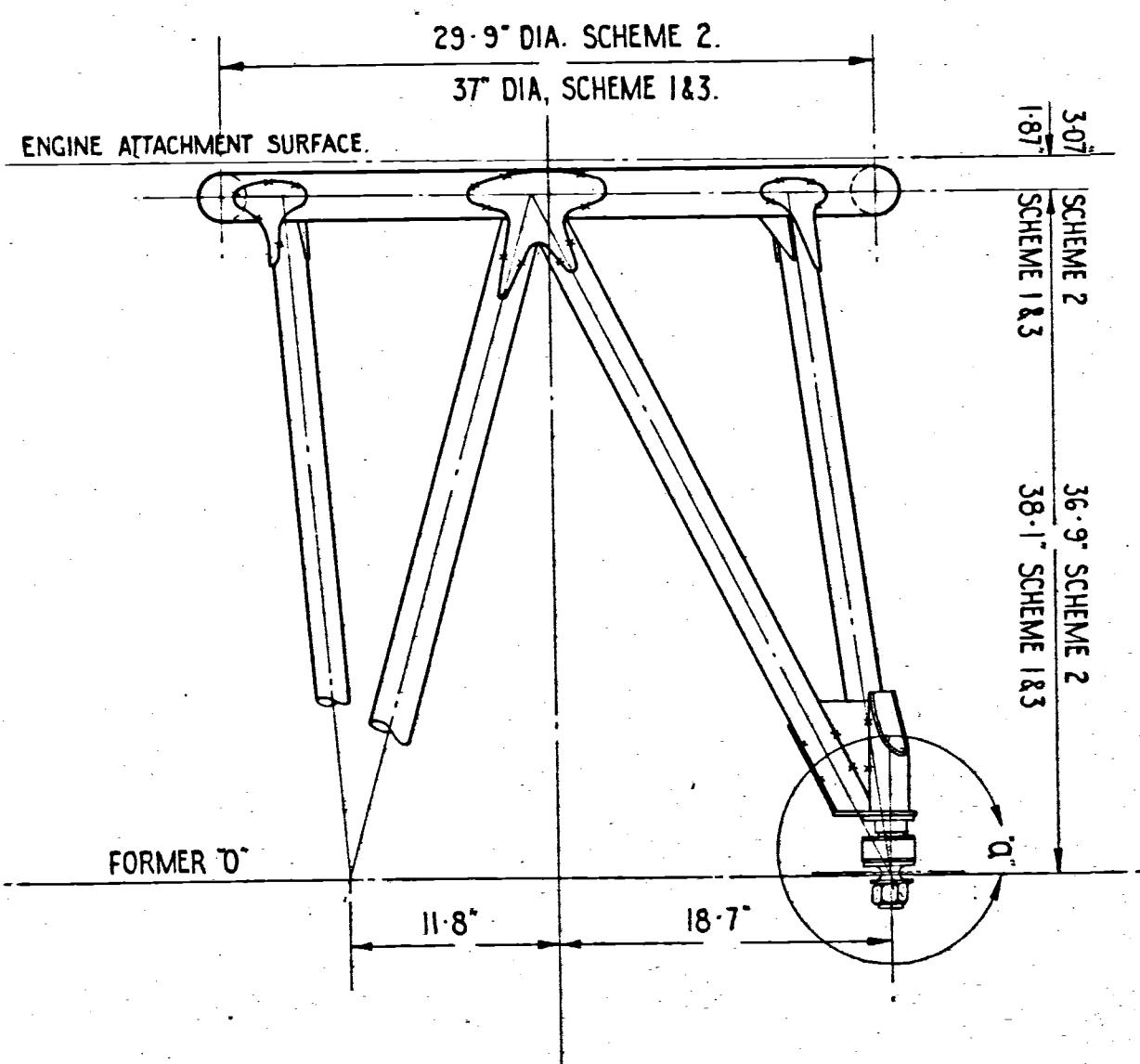
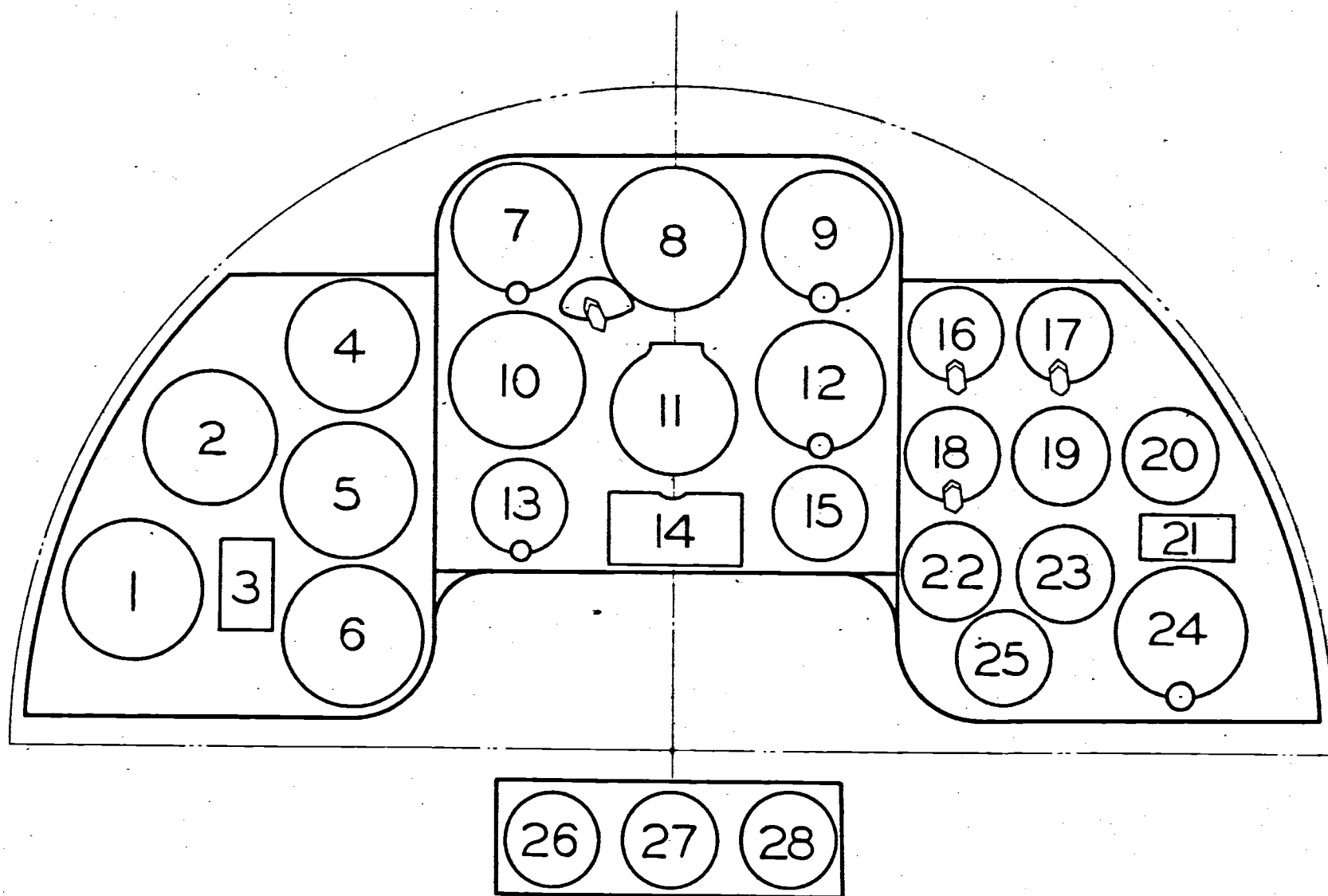

FIG. 25
ENGINE MOUNTING CONSTRUCTION
DIAGRAM

SCALES: 1/10 & 1/2

FIG. 29. INSTRUMENT LAYOUT.



- | | |
|---|---|
| 1. UNDERCARRIAGE AND FLAP INDICATOR. | 15. OXYGEN FLOW METER. |
| 2. NO 1 IGNITION SWITCH. | 16. TYPE 2 EXHAUST TEMP. |
| 3. R.P.M. CONTROL. | 17. CYLINDER TEMP. |
| 4. TYPE 2 INJECTOR PRESSURE INDICATOR. | 18. TYPE 1 OIL TEMP. |
| 5. ENGINE, TYPE 100, REMOTE READING TACHOMETER. | 19. TYPE 84 OIL PRESSURE GAUGE. |
| 6. TURBINE, " " " " " | 20. TYPE 98 MODIFIED, OIL GAUGE. |
| 7. TYPE 4 TURN INDICATOR. | 21. FUEL WARNING LIGHT. |
| 8. TYPE 4 ARTIFICIAL HORIZON. | 22. TYPE 1 FUEL PRESSURE GAUGE. |
| 9. TYPE 3 RATE OF CLIMB INDICATOR. | 23. TYPE 1 FUEL PRESSURE GAUGE, AUXILIARY INJECTION. |
| 10. TYPE 3 A.S.I. | 24. TYPE 3 ALTIMETER. (EQUIVALENT ALT. INSIDE CABIN.) |
| 11. TYPE 98 COMPASS. | 25. OIL GAUGE CHANGE OVER SWITCH. |
| 12. TYPE 3 ALTIMETER. | 26. 2 SPEED BOOST PRESSURE GAUGE. |
| 13. TYPE 100 TIME OF FLIGHT INDICATOR. | 27. PUMP PRESSURE GAUGE. |
| 14. CORRECTION CARD. | 28. OXYGEN PRESSURE GAUGE. |

FIG. 1
KI. 94
SCALE: 3/40

